

4.4. The Linear Momentum Equations (LMEs)

In this section we'll consider Newton's Second law applied to a control volume of fluid. Recall that linear momentum is a vector quantity, it has both magnitude and direction, and is given by mass*velocity. In words and in mathematical terms, Newton's Second Law for a system is:

The rate of change of a system's linear momentum is equal to the net force acting on the system.

$$\Rightarrow \frac{D}{Dt} \underbrace{\int_{V_{\text{sys}}} \mathbf{u}_{XYZ} \rho dV}_{\text{LM of system}} = \mathbf{F}_{\text{on sys}}. \quad (4.37)$$

where D/Dt is the Lagrangian derivative (implying that we're using the rate of change as we follow the system), V is the volume, and ρ is the density. The quantity \mathbf{u}_{XYZ} represents the velocity of a small piece of fluid in the system with respect to an inertial (aka non-accelerating) coordinate system XYZ (Figure 4.8). Recall that Newton's Second law holds strictly for inertial coordinate systems. Note that a coordinate system moving at a constant velocity in a straight line is non-accelerating and, thus, is inertial.

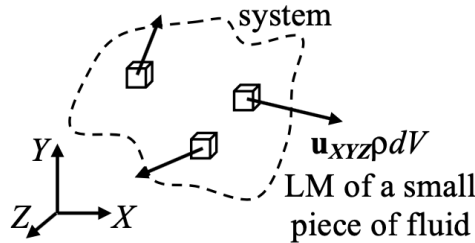

FIGURE 4.8. A system of fluid illustrating the linear momentum associated with a small piece of fluid.

The term, $\mathbf{F}_{\text{on sys}}$, represents the net forces acting on the system. These forces can be of two different types. The first are body forces, \mathbf{F}_{body} , and the second are surface forces, $\mathbf{F}_{\text{surface}}$. Body forces are those forces that act on each piece of fluid in the system, including the interior system volume. Examples include gravitational and electromagnetic forces. Surface forces are those forces acting only at the surface of the system. Examples of surface forces include pressure and shear forces. Expanding the force term,

$$\mathbf{F}_{\text{on sys}} = \mathbf{F}_{\text{body, on sys}} + \mathbf{F}_{\text{surface, on sys}}. \quad (4.38)$$

Using the Reynolds Transport Theorem to convert the left-hand side of Eq. (4.37) from a system point of view to an expression for a control volume gives,

$$\frac{D}{Dt} \int_{V_{\text{sys}}} \mathbf{u}_{XYZ} \rho dV = \frac{d}{dt} \int_{CV} \mathbf{u}_{XYZ} \rho dV + \int_{CS} \mathbf{u}_{XYZ} (\rho \mathbf{u}_{\text{rel}} \cdot d\mathbf{A}). \quad (4.39)$$

Since the Reynolds Transport Theorem is applied to a coincident system and control volume, the forces acting on the system will also act on the control volume. Thus,

$$\boxed{\underbrace{\frac{d}{dt} \int_{CV} \mathbf{u}_{XYZ} \rho dV}_{\text{rate of increase of LM in CV}} + \underbrace{\int_{CS} \mathbf{u}_{XYZ} (\rho \mathbf{u}_{\text{rel}} \cdot d\mathbf{A})}_{\text{net rate at which LM leaves the CV}} = \underbrace{\mathbf{F}_{B, \text{on CV}}}_{\text{net body force on the CV}} + \underbrace{\mathbf{F}_{S, \text{on CV}}}_{\text{net surface force on the CV}}} \quad (4.40)$$

This is the Linear Momentum Equation for a control volume!

Notes:

- (1) Recall that the LME is a vector expression. There are actually three equations built into Eq. (4.40). For example, in a rectangular coordinate system (Cartesian coordinates) we have,

$$\frac{d}{dt} \int_{CV} u_X \rho dV + \int_{CS} u_X (\rho \mathbf{u}_{\text{rel}} \cdot d\mathbf{A}) = F_{B,X} + F_{S,X} \quad (4.41)$$

$$\frac{d}{dt} \int_{CV} u_Y \rho dV + \int_{CS} u_Y (\rho \mathbf{u}_{\text{rel}} \cdot d\mathbf{A}) = F_{B,Y} + F_{S,Y} \quad (4.42)$$

$$\frac{d}{dt} \int_{CV} u_Z \rho dV + \int_{CS} u_Z (\rho \mathbf{u}_{\text{rel}} \cdot d\mathbf{A}) = F_{B,Z} + F_{S,Z} \quad (4.43)$$

- (2) When applying the Linear Momentum Equations, Conservation of Mass is often used too. This point is illustrated in the examples at the end of this section.
- (3) Note that the velocity \mathbf{u}_{XYZ} in the CV term in Eq. (4.40) is the velocity of fluid *within the CV* using inertial coordinate system XYZ . The velocity \mathbf{u}_{XYZ} in the CS term of Eq. (4.40) is the velocity of fluid *as it crosses the CS* using inertial coordinate system XYZ . The subscript on the integral is important!
- (4) It is important to distinguish between the two velocities \mathbf{u}_{XYZ} and \mathbf{u}_{rel} in the CS term in Eq. (4.40). The velocity \mathbf{u}_{XYZ} represents the fluid velocity with respect to an inertial coordinate system XYZ , e.g., a coordinate system fixed in space or moving at a constant velocity in a straight line. The velocity \mathbf{u}_{rel} is the velocity of the fluid as it crosses the control surface, e.g., $\mathbf{u}_{\text{rel}} = \mathbf{u}_{\text{fluid}} - \mathbf{u}_{CS}$. The velocity \mathbf{u}_{XYZ} *must* be measured using the inertial coordinate system XYZ ; however, the relative velocity \mathbf{u}_{rel} can be measured using *any* coordinate system since it is a difference of two velocities.

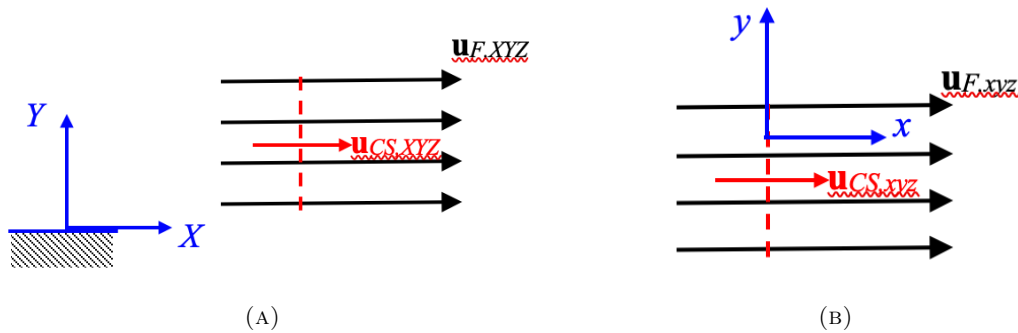

FIGURE 4.9. Sketches corresponding to the relative velocity example. (A) Using a coordinate system fixed to the ground. (B) Using a coordinate system fixed to the moving control surface.

To illustrate this point, consider a fluid flowing in a straight line with velocity $\mathbf{u}_{F,XYZ}$ using the fixed coordinate system XYZ shown in Figure 4.9. Also shown in the figure is a portion of a control surface, which moves at a speed $\mathbf{u}_{CS,XYZ}$ using the same fixed coordinate system. Now let's evaluate the linear momentum flow rate term in Eq. (4.40),

$$\int_{CS} \mathbf{u}_{XYZ} (\rho \mathbf{u}_{\text{rel}} \cdot d\mathbf{A}). \quad (4.44)$$

The velocity \mathbf{u}_{XYZ} is the velocity of the fluid at the control surface using our coordinate system. Hence,

$$\mathbf{u}_{XYZ} = \mathbf{u}_{F,XYZ}. \quad (4.45)$$

The velocity of the fluid at the control surface relative to the control surface is,

$$\mathbf{u}_{\text{rel}} = \mathbf{u}_{\text{fluid}} - \mathbf{u}_{CS} = \mathbf{u}_{F,XYZ} - \mathbf{u}_{CS,XYZ}; \quad (4.46)$$

where both the fluid and control surface velocities are measured using the XYZ coordinate system, for convenience. Substituting back into Eq. (4.44) gives,

$$\int_{CS} \mathbf{u}_{XYZ} (\rho \mathbf{u}_{rel} \cdot d\mathbf{A}) = \int_{CS} \mathbf{u}_{F,XYZ} [\rho (\mathbf{u}_{F,XYZ} - \mathbf{u}_{CS,XYZ}) \cdot d\mathbf{A}]. \quad (4.47)$$

Now let's re-evaluate the momentum flow rate term in Eq (4.40) using a coordinate system *that is fixed to the moving control surface*, which we'll call coordinate system xyz (Figure 4.9),

$$\int_{CS} \mathbf{u}_{xyz} (\rho \mathbf{u}_{rel} \cdot d\mathbf{A}). \quad (4.48)$$

Note that this coordinate system is still inertial since it's moving in a straight line at a constant speed. Using this new coordinate system, the fluid velocity is,

$$\mathbf{u}_{F,xyz} = \mathbf{u}_{F,XYZ} - \mathbf{u}_{CS,XYZ}, \quad (4.49)$$

and the control surface velocity is,

$$\mathbf{u}_{CS,xyz} = \mathbf{u}_{CS,XYZ} - \mathbf{u}_{CS,XYZ} = \mathbf{0}. \quad (4.50)$$

The control surface doesn't appear to be moving using this coordinate system. The fluid velocity relative to the control surface velocity using this new coordinate system is,

$$\mathbf{u}_{rel} = \mathbf{u}_{fluid} - \mathbf{u}_{CS} = \mathbf{u}_{F,xyz} - \mathbf{u}_{CS,xyz} = (\mathbf{u}_{F,XYZ} - \mathbf{u}_{CS,XYZ}) - \mathbf{0}, \quad (4.51)$$

$$\mathbf{u}_{rel} = \mathbf{u}_{F,XYZ} - \mathbf{u}_{CS,XYZ}. \quad (4.52)$$

Substituting Eqs. (4.49) and (4.52) into Eq. (4.48) gives,

$$\int_{CS} \mathbf{u}_{xyz} (\rho \mathbf{u}_{rel} \cdot d\mathbf{A}) = \int_{CS} \mathbf{u}_{F,xyz} [\rho (\mathbf{u}_{F,XYZ} - \mathbf{u}_{CS,XYZ}) \cdot d\mathbf{A}]. \quad (4.53)$$

Note that the relative velocity \mathbf{u}_{rel} is the same regardless of the coordinate system used (compare Eqs. (4.46) and (4.52)). However, the value for the fluid velocity at the control surface, $\mathbf{u}_{F,XYZ}$ or $\mathbf{u}_{F,xyz}$ *does* depend on the choice of coordinate system, i.e., $\mathbf{u}_{F,XYZ} \neq \mathbf{u}_{F,xyz}$. Furthermore, this fluid velocity at the control surface can be different than the relative velocity, in general, i.e., $\mathbf{u}_{XYZ} \neq \mathbf{u}_{rel}$. The only time the two will be the same is if the control surface velocity is zero in the chosen frame of reference. With this in mind, it's often most convenient to fix the coordinate system to the control surface. Several examples are provided in which problems are worked using a fixed coordinate system or one moving at a constant speed in a straight line. The same answer is obtained regardless of the choice of coordinate system, but it is almost always easiest to use a coordinate system fixed to the control surface.

- (5) So far we've only discussed the LME for inertial (aka non-accelerating) coordinate systems. We can also apply the LME to non-inertial (aka accelerating) coordinate systems, but we need to add additional acceleration terms. We'll consider accelerating coordinate systems later in this chapter.
- (6) In order to avoid mistakes when analyzing problems with the LME, be sure to do the following:
 - (a) Unambiguously draw the control volume that the LME is being applied to.
 - (b) Clearly indicate the coordinate system that is being used. Identify if the coordinate system is inertial or non-inertial.
 - (c) Draw a free body diagram (FBD) of the relevant forces. Include both body and surface forces.
 - (d) State any significant assumptions that may be used to simplify the LME, e.g., steady state, incompressible fluid, etc.
 - (e) Write the significant components of the LME and then indicate the value of each term in the equation.
 - (f) Carefully evaluate the velocity terms. This step is where many mistakes are made.
 - (g) You must integrate the terms in the linear momentum equation when the density or velocity are not uniform.
 - (h) Don't forget to include pressure and shear forces in the surface force term.
 - (i) Don't forget to include the weight of everything inside the control volume when gravitational body forces are significant.

While these things may seem trivial and unnecessary, writing them down in a clear and concise manner can greatly reduce the likelihood of mistakes and better communicate your analysis to others.

- (7) Note that the first term on the left-hand side of Eq. (4.40) is the rate of increase of linear momentum in the CV, which can be re-written as,

$$\frac{d}{dt} \int_{CV} \mathbf{u}_{XYZ} \rho dV = \frac{d}{dt} (\mathbf{L}_{CV,XYZ}) = \frac{d\mathbf{L}_{CV,XYZ}}{dt}, \quad (4.54)$$

where $\mathbf{L}_{CV,XYZ}$ is the linear momentum contained within the CV with respect to the inertial coordinate system XYZ . Similarly, the second term on the left-hand side of Eq. (4.40), which is the net rate at which linear momentum leaves the CV through the CS, may be written as,

$$\int_{CS} \mathbf{u}_{XYZ} (\rho \mathbf{u}_{rel} \cdot d\mathbf{A}) = \sum_{\text{all outlets}} \dot{\mathbf{L}}_{XYZ} - \sum_{\text{all inlets}} \dot{\mathbf{L}}_{XYZ}, \quad (4.55)$$

where $\dot{\mathbf{L}}_{XYZ}$ is the rate at which linear momentum, evaluated using the inertial coordinate system XYZ , passes through the control surface. Combining Eqs. (4.40), (4.54), and (4.55) gives,

$$\frac{d\mathbf{L}_{CV,XYZ}}{dt} = \sum_{\text{all inlets}} \dot{\mathbf{L}}_{XYZ} - \sum_{\text{all outlets}} \dot{\mathbf{L}}_{XYZ}. \quad (4.56)$$

Let's consider a few examples to see how LME using an inertial coordinate system is applied.

- A jet of water is deflected by a vane mounted on a cart. The water jet has an area, A , everywhere and is turned an angle θ with respect to the horizontal. The pressure everywhere within the jet is atmospheric. The incoming jet velocity with respect to the ground (axes XY) is V_{jet} . The cart has mass M . Determine:
- the force components, F_x and F_y , required to hold the cart stationary,
 - the horizontal force component, F_x , if the cart moves to the right at the constant velocity, V_{cart} ($V_{cart} < V_{jet}$)

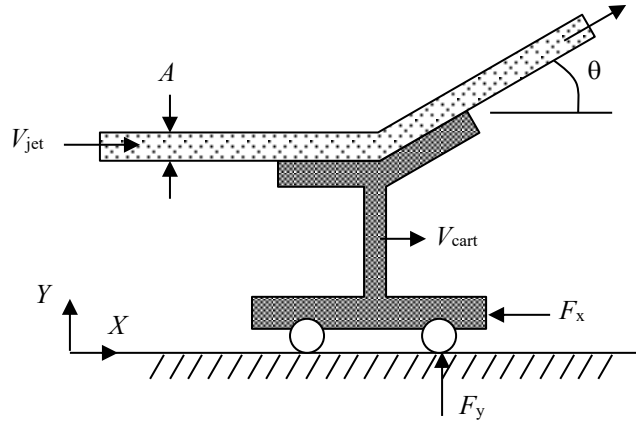

SOLUTION:

Part (a):

Apply conservation of mass and the linear momentum equation to a control volume surrounding the cart. Use an inertial frame of reference fixed to the ground (XY).

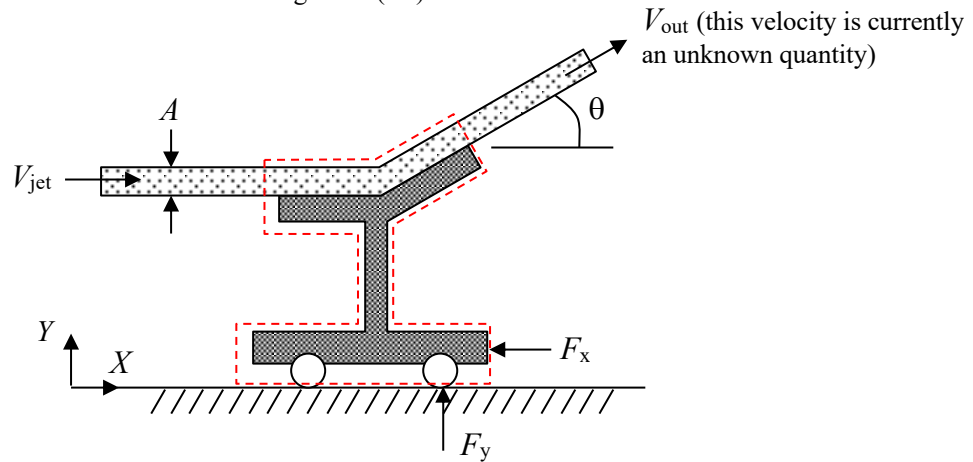

First apply conservation of mass to the control volume to determine V_{out} .

$$\frac{d}{dt} \int_{CV} \rho dV + \int_{CS} \rho \mathbf{u}_{rel} \cdot d\mathbf{A} = 0 \tag{1}$$

where

$$\frac{d}{dt} \int_{CV} \rho dV = 0 \quad (\text{the mass within the control volume doesn't change})$$

$$\begin{aligned} \int_{CS} \rho \mathbf{u}_{rel} \cdot d\mathbf{A} &= \underbrace{\left(\overbrace{\rho V_{jet} \hat{\mathbf{i}} \cdot -A \hat{\mathbf{i}}}^{\substack{=\mathbf{u}_{rel} \\ =\mathbf{A}}} \right)}_{\text{left side}} + \underbrace{\left[\overbrace{\rho V_{out} (\cos \theta \hat{\mathbf{i}} + \sin \theta \hat{\mathbf{j}})}^{\substack{=\mathbf{u}_{rel} \\ =\mathbf{A}}} \right] \cdot \overbrace{A (\cos \theta \hat{\mathbf{i}} + \sin \theta \hat{\mathbf{j}})}^{\substack{=\mathbf{u}_{rel} \\ =\mathbf{A}}} \right]}_{\text{right side}} \\ &= -\rho V_{jet} A + \rho V_{out} A \underbrace{(\cos^2 \theta + \sin^2 \theta)}_{=1} \\ &= -\rho V_{jet} A + \rho V_{out} A \end{aligned}$$

(Note that the jet area remains constant.)

Substitute and re-arrange.

$$-\rho V_{jet} A + \rho V_{out} A = 0$$

$$V_{out} = V_{jet} \quad (2)$$

Now apply the linear momentum equation in the X -direction:

$$\frac{d}{dt} \int_{CV} u_X \rho dV + \int_{CS} u_X \rho \mathbf{u}_{rel} \cdot d\mathbf{A} = F_{B,X} + F_{S,X} \quad (3)$$

where

$$\frac{d}{dt} \int_{CV} u_X \rho dV = 0 \quad (\text{the momentum within the control volume doesn't change with time})$$

$$\begin{aligned} \int_{CS} u_X (\rho \mathbf{u}_{rel} \cdot d\mathbf{A}) &= \underbrace{\left(\overbrace{V_{jet}}^{\substack{=u_X \\ =V_{jet}}} \right) \left(\overbrace{\rho V_{jet} \hat{\mathbf{i}} \cdot -A \hat{\mathbf{i}}}^{\substack{=\mathbf{u}_{rel} \\ =\mathbf{A}}} \right)}_{\text{left side}} + \underbrace{\left(\overbrace{V_{jet} \cos \theta}^{\substack{=u_X \\ =V_{jet} \cos \theta}} \right) \left[\overbrace{\rho V_{jet} (\cos \theta \hat{\mathbf{i}} + \sin \theta \hat{\mathbf{j}})}^{\substack{=\mathbf{u}_{rel} \\ =\mathbf{A}}} \right] \cdot \overbrace{A (\cos \theta \hat{\mathbf{i}} + \sin \theta \hat{\mathbf{j}})}^{\substack{=\mathbf{u}_{rel} \\ =\mathbf{A}}} \right]}_{\text{right side}} \\ &= -\rho V_{jet}^2 A + \rho V_{jet}^2 A \cos \theta \underbrace{(\cos^2 \theta + \sin^2 \theta)}_{=1} \\ &= \rho V_{jet}^2 A (\cos \theta - 1) \end{aligned}$$

$$F_{B,X} = 0 \quad (\text{no body forces in the } x\text{-direction})$$

$$F_{S,X} = -F_x \quad (\text{all of the pressure forces cancel out})$$

Substitute and re-arrange.

$$\rho V_{jet}^2 A (\cos \theta - 1) = -F_x$$

$$\boxed{F_x = \rho V_{jet}^2 A (1 - \cos \theta)} \quad (4)$$

Now look at the Y -direction:

$$\frac{d}{dt} \int_{CV} u_y \rho dV + \int_{CS} u_y \rho \mathbf{u}_{rel} \cdot d\mathbf{A} = F_{B,Y} + F_{S,Y} \quad (5)$$

where

$$\frac{d}{dt} \int_{CV} u_y \rho dV = 0 \quad (\text{the momentum within the control volume doesn't change with time})$$

$$\begin{aligned} \int_{CS} u_y (\rho \mathbf{u}_{rel} \cdot d\mathbf{A}) &= \overbrace{(V_{jet} \sin \theta)}^{=u_y} \left[\underbrace{\rho V_{jet} (\cos \theta \hat{\mathbf{i}} + \sin \theta \hat{\mathbf{j}})}_{\text{right side}} \cdot \underbrace{A (\cos \theta \hat{\mathbf{i}} + \sin \theta \hat{\mathbf{j}})}_{=A} \right] \\ &= \rho V_{jet}^2 A \sin \theta \underbrace{(\cos^2 \theta + \sin^2 \theta)}_{=1} \\ &= \rho V_{jet}^2 A \sin \theta \end{aligned}$$

$$F_{B,Y} = -Mg \quad (\text{assume that the fluid weight in the CV is negligible compared to the cart weight})$$

$$F_{S,Y} = F_y \quad (\text{all of the pressure forces cancel out})$$

Substitute and re-arrange.

$$\rho V_{jet}^2 A \sin \theta = -Mg + F_y$$

$$\boxed{F_y = \rho V_{jet}^2 A \sin \theta + Mg} \quad (6)$$

Part (b):

Apply the linear momentum equation to a control volume surrounding the cart. Use a frame of reference fixed to the cart (xy). Note that this is an inertial frame of reference since the cart moves in a straight line at a constant speed. In addition, in this frame of reference, the cart appears stationary and the jet velocity at the left is equal to $V_{\text{jet}} - V_{\text{cart}}$.

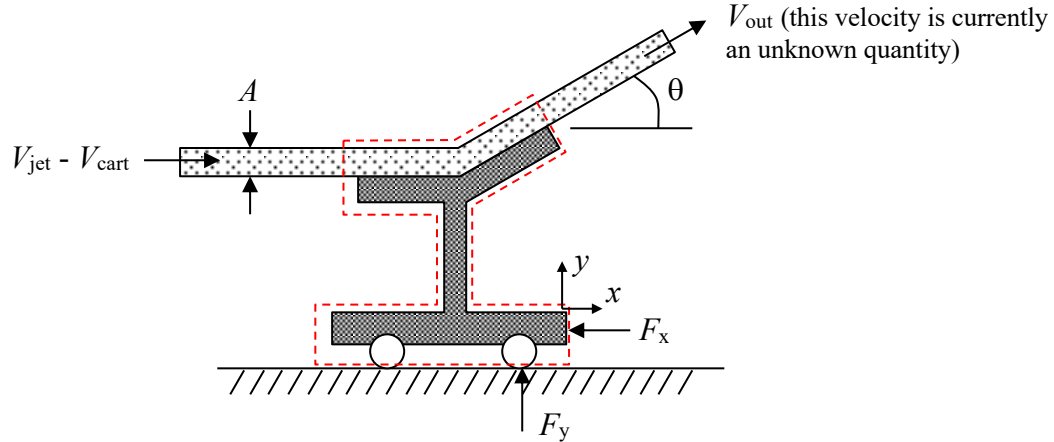

First apply conservation of mass to the control volume to determine V_{out}

$$\frac{d}{dt} \int_{\text{CV}} \rho dV + \int_{\text{CS}} \rho \mathbf{u}_{\text{rel}} \cdot d\mathbf{A} = 0 \quad (7)$$

where

$$\frac{d}{dt} \int_{\text{CV}} \rho dV = 0 \quad (\text{the mass within the control volume doesn't change})$$

$$\begin{aligned} \int_{\text{CS}} \rho \mathbf{u}_{\text{rel}} \cdot d\mathbf{A} &= \underbrace{\left[\rho \overbrace{(V_{\text{jet}} - V_{\text{cart}})}^{=\mathbf{u}_{\text{rel}}} \hat{\mathbf{i}} \cdot \overbrace{-A\hat{\mathbf{i}}}^{=d\mathbf{A}} \right]}_{\text{left side}} + \underbrace{\left[\rho V_{\text{out}} \overbrace{(\cos\theta\hat{\mathbf{i}} + \sin\theta\hat{\mathbf{j}})}^{=\mathbf{u}_{\text{rel}}} \cdot \overbrace{A(\cos\theta\hat{\mathbf{i}} + \sin\theta\hat{\mathbf{j}})}^{=d\mathbf{A}} \right]}_{\text{right side}} \\ &= -\rho(V_{\text{jet}} - V_{\text{cart}})A + \rho V_{\text{out}} A \underbrace{(\cos^2\theta + \sin^2\theta)}_{=1} \\ &= -\rho(V_{\text{jet}} - V_{\text{cart}})A + \rho V_{\text{out}} A \end{aligned}$$

(Note that the jet area remains constant.)

Substitute and re-arrange.

$$\begin{aligned} -\rho(V_{\text{jet}} - V_{\text{cart}})A + \rho V_{\text{out}} A &= 0 \\ V_{\text{out}} &= V_{\text{jet}} - V_{\text{cart}} \end{aligned} \quad (8)$$

Now apply the linear momentum equation in the x -direction:

$$\frac{d}{dt} \int_{\text{CV}} u_x \rho dV + \int_{\text{CS}} u_x \rho \mathbf{u}_{\text{rel}} \cdot d\mathbf{A} = F_{B,x} + F_{S,x} \quad (9)$$

where,

$$\frac{d}{dt} \int_{\text{CV}} u_x \rho dV = 0 \quad (\text{the momentum within the control volume doesn't change with time})$$

$$\begin{aligned}
 \int_{CS} u_x (\rho \mathbf{u}_{rel} \cdot d\mathbf{A}) &= \underbrace{\overbrace{(V_{jet} - V_{cart})}^{=u_x} \left[\rho \overbrace{(V_{jet} - V_{cart})}^{=\mathbf{u}_{rel}} \hat{\mathbf{i}} \cdot \overbrace{-A\hat{\mathbf{i}}}^{=\mathbf{A}} \right]}_{\text{left side}} + \underbrace{\overbrace{(V_{jet} - V_{cart}) \cos \theta}^{=u_x} \left[\rho \overbrace{(V_{jet} - V_{cart})}^{=\mathbf{u}_{rel}} (\cos \theta \hat{\mathbf{i}} + \sin \theta \hat{\mathbf{j}}) \cdot \overbrace{A(\cos \theta \hat{\mathbf{i}} + \sin \theta \hat{\mathbf{j}})}^{=\mathbf{A}} \right]}_{\text{right side}} \\
 &= -\rho (V_{jet} - V_{cart})^2 A + \rho (V_{jet} - V_{cart})^2 A \underbrace{\cos \theta (\cos^2 \theta + \sin^2 \theta)}_{=1} \\
 &= \rho (V_{jet} - V_{cart})^2 A (\cos \theta - 1)
 \end{aligned}$$

$$F_{B,x} = 0 \quad (\text{no body forces in the } x\text{-direction})$$

$$F_{S,x} = -F_x \quad (\text{all of the pressure forces cancel out})$$

Substitute and re-arrange.

$$\rho (V_{jet} - V_{cart})^2 A (\cos \theta - 1) = -F_x$$

$$\boxed{F_x = \rho (V_{jet} - V_{cart})^2 A (1 - \cos \theta)} \quad (10)$$

Now solve the problem using an inertial frame of reference fixed to the ground (frame XY). From Eqn. (8) we know that using a frame of reference fixed to the cart, the jet velocity on the right-hand side is:

$$\mathbf{V}_{\text{out, relative to cart}} = (V_{jet} - V_{cart}) (\cos \theta \hat{\mathbf{i}} + \sin \theta \hat{\mathbf{j}}) \quad (11)$$

Hence, relative to the ground the jet velocity on the right-hand side is:

$$\mathbf{V}_{\text{out, relative to ground}} = \mathbf{V}_{\text{out, relative to cart}} + \mathbf{V}_{\text{cart}} = (V_{jet} - V_{cart}) (\cos \theta \hat{\mathbf{i}} + \sin \theta \hat{\mathbf{j}}) + V_{cart} \hat{\mathbf{i}} \quad (12)$$

Now consider conservation of linear momentum in the X direction.

$$\frac{d}{dt} \int_{CV} u_x \rho dV + \int_{CS} u_x \rho \mathbf{u}_{rel} \cdot d\mathbf{A} = F_{B,x} + F_{S,x} \quad (13)$$

where,

$$\frac{d}{dt} \int_{CV} u_x \rho dV = 0 \quad (\text{the momentum within the control volume doesn't change with time})$$

$$\begin{aligned}
 \int_{CS} u_x (\rho \mathbf{u}_{rel} \cdot d\mathbf{A}) &= \underbrace{\overbrace{V_{jet}}^{=u_x} \left[\rho \overbrace{(V_{jet} - V_{cart})}^{=\mathbf{u}_{rel}} \hat{\mathbf{i}} \cdot \overbrace{-A\hat{\mathbf{i}}}^{=\mathbf{A}} \right]}_{\text{left side}} + \underbrace{\overbrace{[(V_{jet} - V_{cart}) \cos \theta + V_{cart}]}^{=u_x} \left[\rho \overbrace{(V_{jet} - V_{cart})}^{=\mathbf{u}_{rel}} (\cos \theta \hat{\mathbf{i}} + \sin \theta \hat{\mathbf{j}}) \cdot \overbrace{A(\cos \theta \hat{\mathbf{i}} + \sin \theta \hat{\mathbf{j}})}^{=\mathbf{A}} \right]}_{\text{right side}} \\
 &= -\rho V_{jet} (V_{jet} - V_{cart}) A + \rho \left[(V_{jet} - V_{cart})^2 \cos \theta + V_{cart} (V_{jet} - V_{cart}) \right] A \underbrace{(\cos^2 \theta + \sin^2 \theta)}_{=1} \\
 &= \rho \left[-V_{jet}^2 + V_{jet} V_{cart} + (V_{jet} - V_{cart})^2 \cos \theta + V_{cart} V_{jet} - V_{cart}^2 \right] A \\
 &= \rho \left[(V_{jet} - V_{cart})^2 \cos \theta - (V_{jet} - V_{cart})^2 \right] A \\
 &= \rho (V_{jet} - V_{cart})^2 (\cos \theta - 1) A
 \end{aligned}$$

$$F_{B,x} = 0 \quad (\text{no body forces in the } x\text{-direction})$$

$$F_{S,x} = -F_x \quad (\text{all of the pressure forces cancel out})$$

Substitute and re-arrange.

$$\rho (V_{jet} - V_{cart})^2 A (\cos \theta - 1) = -F_x$$

$$\boxed{F_x = \rho (V_{jet} - V_{cart})^2 A (1 - \cos \theta)} \quad (\text{Same answer as before!}) \quad (14)$$

Note that using a frame of reference that is fixed to the control volume is easier than using one fixed to the ground. This is often the case.

A fluid enters a horizontal, circular cross-sectioned, sudden contraction nozzle. At section 1, which has diameter D_1 , the velocity is uniformly distributed and equal to V_1 . The gage pressure at 1 is p_1 . The fluid exits into the atmosphere at section 2, with diameter D_2 . Determine the force in the bolts required to hold the contraction in place. Neglect gravitational effects and assume that the fluid is inviscid.

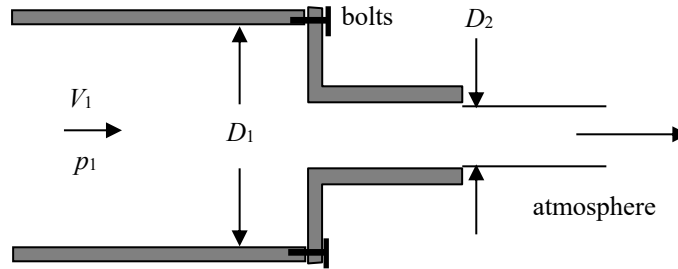

SOLUTION:

Apply the linear momentum equation in the X -direction to the fixed control volume shown below.

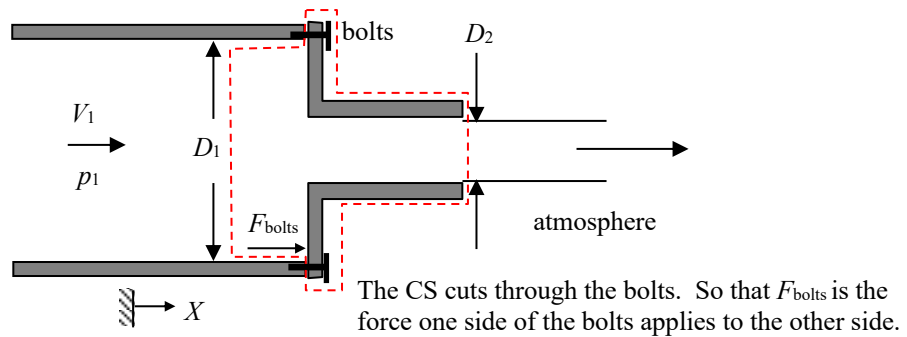

$$\frac{d}{dt} \int_{CV} u_X \rho dV + \int_{Cs} u_X (\rho \mathbf{u}_{rel} \cdot d\mathbf{A}) = F_{B,X} + F_{S,X} \tag{1}$$

where

$$\frac{d}{dt} \int_{CV} u_X \rho dV = 0 \quad (\text{steady flow})$$

$$\int_{Cs} u_X (\rho \mathbf{u}_{rel} \cdot d\mathbf{A}) = \rho \frac{u_X}{V_1} \left(\frac{u_{rel}}{V_1} \hat{\mathbf{i}} \cdot \frac{\pi D_1^2}{4} \hat{\mathbf{i}} \right) + \rho \frac{u_X}{V_2} \left(\frac{u_{rel}}{V_2} \hat{\mathbf{i}} \cdot \frac{\pi D_2^2}{4} \hat{\mathbf{i}} \right) = -\rho V_1^2 \frac{\pi D_1^2}{4} + \rho V_2^2 \frac{\pi D_2^2}{4}$$

(Note that V_2 is unknown for now.)

$$F_{B,X} = 0$$

$$F_{S,X} = p_{1,gage} \frac{\pi D_1^2}{4} + F_{bolts}$$

(Note that $p_{2,gage} = 0$ since $p_{2,abs} = p_{atm}$. We could have also worked the problem using absolute pressures everywhere. The pressure force on the left hand side would be $p_{1,abs} \pi D_1^2 / 4$ and the pressure force on the right hand side would be $p_{atm} \pi D_1^2 / 4$ (note that the diameter is D_1 and not D_2).)

Substitute and re-arrange.

$$-\rho V_1^2 \frac{\pi D_1^2}{4} + \rho V_2^2 \frac{\pi D_2^2}{4} = p_{1,\text{gage}} \frac{\pi D_1^2}{4} + F_{\text{bolts}}$$

$$F_{\text{bolts}} = -\rho V_1^2 \frac{\pi D_1^2}{4} + \rho V_2^2 \frac{\pi D_2^2}{4} - p_{1,\text{gage}} \frac{\pi D_1^2}{4} \quad (2)$$

To determine V_2 , apply conservation of mass to the same control volume.

$$\frac{d}{dt} \int_{\text{CV}} \rho dV + \int_{\text{Cs}} \rho \mathbf{u}_{\text{rel}} \cdot d\mathbf{A} = 0 \quad (3)$$

where

$$\frac{d}{dt} \int_{\text{CV}} \rho dV = 0$$

$$\int_{\text{Cs}} \rho \mathbf{u}_{\text{rel}} \cdot d\mathbf{A} = -\rho V_1 \frac{\pi D_1^2}{4} + \rho V_2 \frac{\pi D_2^2}{4}$$

Substitute and simplify.

$$-\rho V_1 \frac{\pi D_1^2}{4} + \rho V_2 \frac{\pi D_2^2}{4} = 0$$

$$V_2 = V_1 \left(\frac{D_1}{D_2} \right)^2 \quad (4)$$

Substitute Eqn. (4) into Eqn. (2) and simplify.

$$F_{\text{bolts}} = -\rho V_1^2 \frac{\pi D_1^2}{4} + \rho V_1^2 \left(\frac{D_1}{D_2} \right)^4 \frac{\pi D_2^2}{4} - p_{1,\text{gage}} \frac{\pi D_1^2}{4}$$

$$F_{\text{bolts}} = \rho V_1^2 \frac{\pi D_1^2}{4} \left[\left(\frac{D_1}{D_2} \right)^2 - 1 \right] - p_{1,\text{gage}} \frac{\pi D_1^2}{4} \quad (5)$$

Note that F_{bolts} was assumed to be positive when acting in the $+X$ direction (causing compression in the bolts). If $F_{\text{bolts}} < 0$ then the bolts will be in tension.

Water is sprayed radially outward through 180° as shown in the figure. The jet sheet is in the horizontal plane and has thickness, H . If the jet volumetric flow rate is Q , determine the resultant horizontal anchoring force required to hold the nozzle stationary.

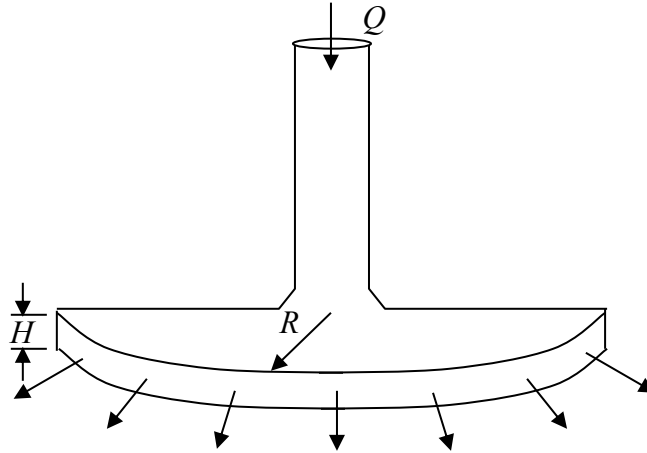

SOLUTION:

Apply the linear momentum equation in the X direction to the fixed control volume shown below.

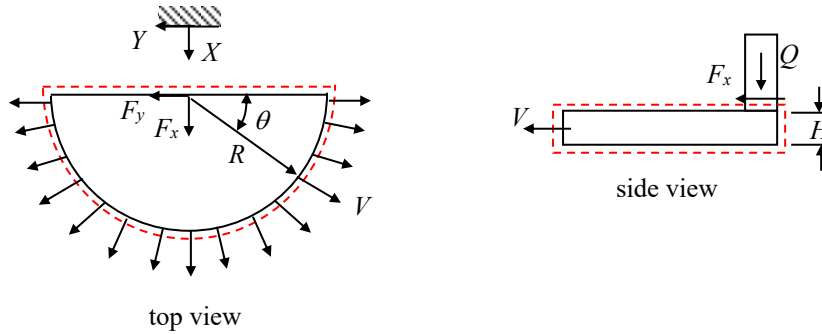

$$\frac{d}{dt} \int_{CV} u_X \rho dV + \int_{CS} u_X (\rho \mathbf{u}_{rel} \cdot d\mathbf{A}) = F_{B,X} + F_{S,X} \quad (1)$$

where

$$\frac{d}{dt} \int_{CV} u_X \rho dV = 0 \quad (\text{steady flow})$$

$$\begin{aligned} \int_{CS} u_X (\rho \mathbf{u}_{rel} \cdot d\mathbf{A}) &= \int_{\theta=0}^{\theta=\pi} \overbrace{(V \sin \theta)}^{=u_X} \left(\rho V \overbrace{Rd\theta H}^{=dA} \right) = \rho V^2 R H \int_{\theta=0}^{\theta=\pi} \sin \theta d\theta = -\rho V^2 R H \cos \theta \Big|_0^\pi \\ &= -\rho V^2 R H (-1 - 1) \\ &= 2\rho V^2 R H \end{aligned}$$

(Note that there is no X -momentum at the control volume inlet. Also, V is an unknown quantity at the moment.)

$$F_{B,X} = 0$$

$$F_{S,X} = F_x \quad (\text{All of the pressure forces cancel and only the anchoring force remains.})$$

Substitute.

$$F_x = 2\rho V^2 RH \quad (2)$$

To determine V , apply conservation of mass to the same control volume.

$$\frac{d}{dt} \int_{CV} \rho dV + \int_{CS} \rho \mathbf{u}_{rel} \cdot d\mathbf{A} = 0 \quad (3)$$

where

$$\frac{d}{dt} \int_{CV} \rho dV = 0 \quad (\text{steady flow})$$

$$\int_{CS} \rho \mathbf{u}_{rel} \cdot d\mathbf{A} = \underbrace{-\rho Q}_{\text{inlet}} + \underbrace{\int_{\theta=0}^{\theta=\pi} \rho V R d\theta H}_{\text{outlet}} = -\rho Q + \rho V \pi RH$$

Substitute and simplify.

$$-\rho Q + \rho V \pi RH = 0$$

$$V = \frac{Q}{\pi RH} \quad (4)$$

Substitute Eqn. (4) into Eqn. (2).

$$\boxed{F_x = 2\rho \left(\frac{Q}{\pi RH} \right)^2 RH} \quad (5)$$

Note that $F_y = 0$ due to symmetry.

A variable mesh screen produces a linear and axi-symmetric velocity profile as shown in the figure. The static pressure upstream and downstream of the screen are p_1 and p_2 respectively (and are uniformly distributed). If the flow upstream of the mesh is uniformly distributed and equal to V_1 , determine the force the mesh screen exerts on the fluid. Assume that the pipe wall does not exert any force on the fluid.

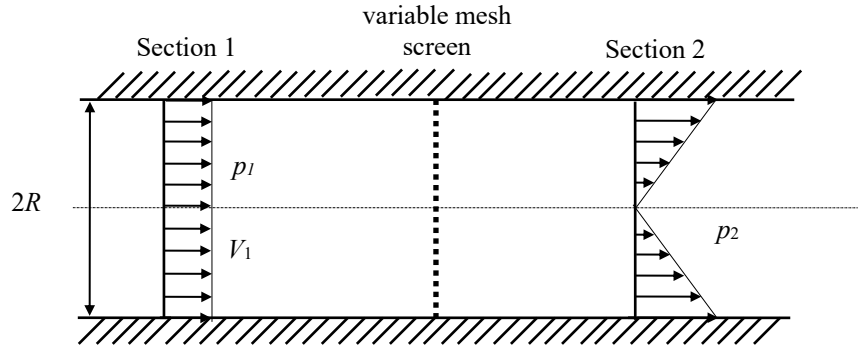

SOLUTION:

First, note that the linear velocity profile at the outlet may be written as,

$$V = V_{\max} \frac{r}{R}, \tag{1}$$

where V_{\max} is the flow velocity at $r = R$. Now apply Conservation of Mass to the fixed control volume shown in the figure to find V_{\max} in terms of the upstream properties,

$$\frac{d}{dt} \int_{CV} \rho dV + \int_{CV} \rho \mathbf{u}_{\text{rel}} \cdot d\mathbf{A} = 0, \tag{2}$$

where,

$$\frac{d}{dt} \int_{CV} \rho dV = 0 \quad (\text{steady state}), \tag{3}$$

$$\int_{CV} \rho \mathbf{u}_{\text{rel}} \cdot d\mathbf{A} = \underbrace{-\rho V_1 \pi R^2}_{\text{left side}} + \underbrace{\int_{r=0}^{r=R} \rho \left(V_{\max} \frac{r}{R} \right) (2\pi r dr)}_{\text{right side}} \tag{4}$$

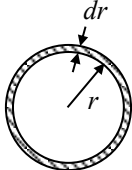

 $dA = 2\pi r dr$

$$= -\rho V_1 \pi R^2 + \rho \frac{2}{3} \pi V_{\max} R^2$$

Substitute and simplify,

$$-\rho V_1 \pi R^2 + \rho \frac{2}{3} \pi V_{\max} R^2 = 0 \tag{5}$$

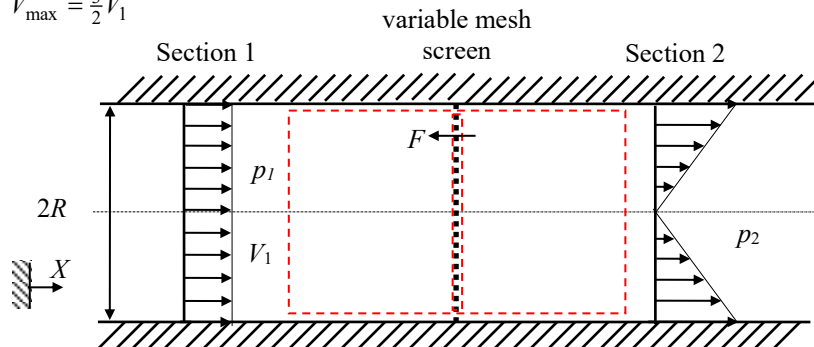
$$V_{\max} = \frac{3}{2} V_1 \tag{6}$$



The control volume weaves in and out of the mesh so that the mesh is not part of the control volume, and instead exerts a force, F , on the control volume.

Now apply the Linear Momentum Equation in the X -direction to the fixed control volume shown in the figure,

$$\frac{d}{dt} \int_{CV} u_X \rho dV + \int_{CV} u_X (\rho \mathbf{u}_{rel} \cdot d\mathbf{A}) = F_{B,X} + F_{S,X}, \quad (7)$$

where,

$$\frac{d}{dt} \int_{CV} u_X \rho dV = 0 \quad (\text{steady state}), \quad (8)$$

$$\int_{CS} u_X (\rho \mathbf{u}_{rel} \cdot d\mathbf{A}) = \underbrace{V_1 (-\rho V_1 \pi R^2)}_{\text{left side}} + \underbrace{\int_{r=0}^{r=R} \left(\frac{3}{2} V_1 \frac{r}{R} \right) \left[\rho \left(\frac{3}{2} V_1 \frac{r}{R} \right) (2\pi r dr) \right]}_{\text{right side}}, \quad (9)$$

$$= -\rho V_1^2 \pi R^2 + \frac{9\pi \rho V_1^2}{2 R^2} \int_0^R r^3 dr, \quad (10)$$

$$= -\rho V_1^2 \pi R^2 + \frac{9}{8} \rho V_1^2 \pi R^2 = \frac{1}{8} \rho V_1^2 \pi R^2, \quad (11)$$

$$F_{B,X} = 0, \quad (12)$$

$$F_{S,X} = -F + p_1 \pi R^2 - p_2 \pi R^2. \quad (13)$$

Substitute and simplify,

$$\frac{1}{8} \rho V_1^2 \pi R^2 = -F + p_1 \pi R^2 - p_2 \pi R^2, \quad (14)$$

$$\boxed{F = (p_1 - p_2) \pi R^2 - \frac{1}{8} \rho V_1^2 \pi R^2}, \quad (15)$$

This is the force the mesh applies to the control volume (i.e., the fluid). The fluid applies an equal and opposite force to the mesh.

Incompressible fluid of negligible viscosity is pumped, at total volume flow rate Q , through a porous surface into the small gap between closely spaced parallel plates as shown. The fluid has only horizontal motion in the gap. Assume uniform flow across any vertical section. Obtain an expression for the pressure variation as a function of x .

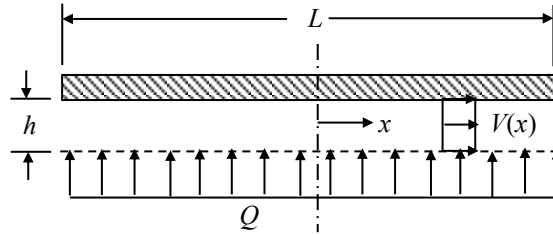

Assume a depth w into the page.

SOLUTION:

Apply conservation of mass to the following differential control volume.

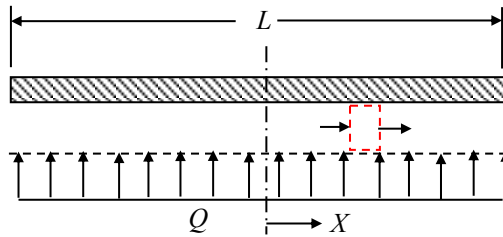

$$\frac{d}{dt} \int_{CV} \rho dV + \int_{CS} \rho \mathbf{u}_{rel} \cdot d\mathbf{A} = 0$$

where

$$\frac{d}{dt} \int_{CV} \rho dV = 0 \quad (\text{steady flow})$$

$$\begin{aligned} \int_{CS} \rho \mathbf{u}_{rel} \cdot d\mathbf{A} &= - \left[\rho V h (w) + \frac{d}{dx} (\rho V h w) \left(-\frac{1}{2} dx\right) \right] + \left[\rho V h w + \frac{d}{dx} (\rho V h w) \left(\frac{1}{2} dx\right) \right] - \rho \frac{Q}{L w} w dx \\ &= \frac{d}{dx} (\rho V h w) dx - \rho \frac{Q}{L w} w dx = \rho h w \frac{dV}{dx} dx - \rho \frac{Q}{L w} w dx \end{aligned}$$

Substituting and simplifying gives:

$$\rho h w \frac{dV}{dx} dx = \rho \frac{Q}{L w} w dx$$

$$\frac{dV}{dx} = \frac{Q}{L h w} \tag{1}$$

$$\int_{V=0}^{V=V} dV = \int_{x=0}^{x=x} \frac{Q}{L h w} dx$$

$$\frac{V h w}{Q} = \frac{x}{L} \quad \text{or} \quad V = \left(\frac{Q}{h w} \right) \left(\frac{x}{L} \right) \tag{2}$$

Now apply the linear momentum equation in the X -direction to the same control volume.

$$\frac{d}{dt} \int_{CV} u_x \rho dV + \int_{CS} u_x (\rho \mathbf{u}_{rel} \cdot d\mathbf{A}) = F_{BX} + F_{SX}$$

where

$$\frac{d}{dt} \int_{CV} u_x \rho dV = 0 \quad (\text{steady flow})$$

$$\begin{aligned} \int_{CS} u_x (\rho \mathbf{u}_{rel} \cdot d\mathbf{A}) &= - \left[\rho V^2 h w + \frac{d}{dx} (\rho V^2 h w) \left(-\frac{1}{2} dx \right) \right] + \left[\rho V^2 h w + \frac{d}{dx} (\rho V^2 h w) \left(\frac{1}{2} dx \right) \right] \\ &= \frac{d}{dx} (\rho V^2 h w) dx = 2\rho V \frac{dV}{dx} h w dx \end{aligned}$$

(Assume unit depth into the page. Note that the flux of mass from the porous surface has no X -momentum.)

$$F_{BX} = 0$$

$$\begin{aligned} F_{SX} &= \left[phw + \frac{d}{dx} (phw) \left(-\frac{1}{2} dx \right) \right] - \left[phw + \frac{d}{dx} (phw) \left(\frac{1}{2} dx \right) \right] \\ &= - \frac{d}{dx} (phw) dx = - \frac{dp}{dx} h w dx \end{aligned}$$

Substituting and simplifying gives:

$$2\rho V \frac{dV}{dx} h w dx = - \frac{dp}{dx} h w dx$$

$$2\rho V \frac{dV}{dx} = - \frac{dp}{dx}$$

Substituting Eqns. (1) and (2) gives:

$$2\rho \left(\frac{Q}{Lhw} \right)^2 x = - \frac{dp}{dx}$$

$$\int_{p=p}^{p=p_{atm}} dp = -2\rho \left(\frac{Q}{Lhw} \right)^2 \int_{x=x}^{x=\frac{1}{2}L} x dx$$

$$p_{atm} - p = -\rho \left(\frac{Q}{Lhw} \right)^2 \left(\frac{1}{4} L^2 - x^2 \right)$$

$$p - p_{atm} = \rho \left(\frac{Q}{hw} \right)^2 \left(\frac{1}{4} - \left(\frac{x}{L} \right)^2 \right)$$

$$\boxed{\frac{p - p_{atm}}{\rho \left(\frac{Q}{hw} \right)^2} = \frac{1}{4} - \left(\frac{x}{L} \right)^2} \quad (3)$$

An incompressible, viscous fluid with density, ρ , flows past a solid flat plate which has a depth, b , into the page. The flow initially has a uniform velocity U_∞ , before contacting the plate. After contact with the plate at a distance x downstream from the leading edge, the flow velocity profile is altered due to the no-slip condition. The velocity profile at location x is estimated to have a parabolic shape, $u=U_\infty((2y/\delta)-(y/\delta)^2)$, for $y \leq \delta$ and $u=U_\infty$ for $y \geq \delta$ where δ is termed the “boundary layer thickness.”

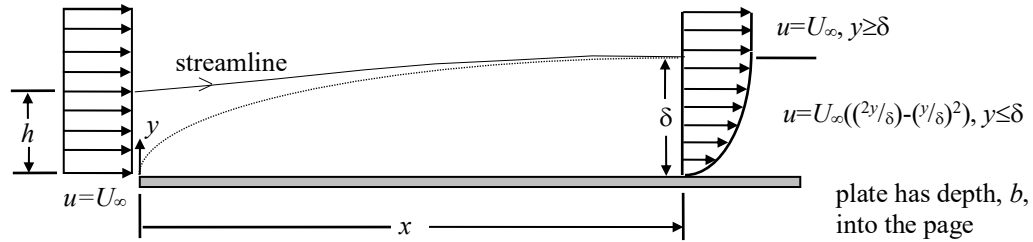

1. Determine the upstream height from the plate, h , of a streamline which has a height, δ , at the downstream distance x . Express your answer in terms of δ .
2. Determine the force the plate exerts on the fluid over the distance x . Express your answer in terms of ρ , U_∞ , b , and δ . You may assume that the pressure everywhere is p_∞ . The force the drag exerts on the plate is called the “skin friction” drag.

BRIEF SOLUTION:

1. Apply conservation of mass to a control volume that is adjacent to the plate, crosses perpendicularly to the stream at the leading edge of the plate, follows a streamline, and crosses perpendicularly to the stream at the location where the boundary layer has thickness, δ . Note that there is no flow across a streamline.
2. Apply the linear momentum equation to the same control volume used in Step 1. Be sure to include the force the plate exerts on the control volume.

DETAILED SOLUTION:

Apply conservation of mass to the fixed control volume shown below.

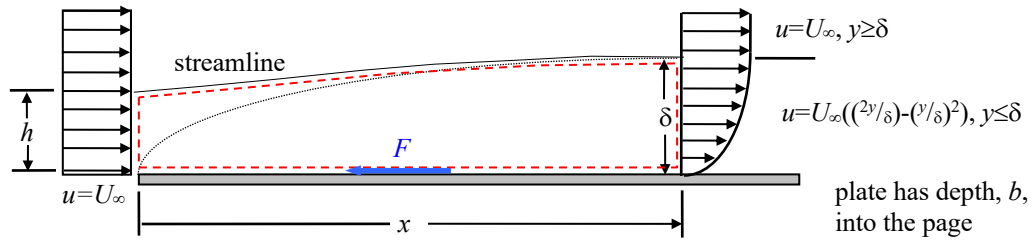

$$\frac{d}{dt} \int_{CV} \rho dV + \int_{CS} \rho \mathbf{u}_{rel} \cdot d\mathbf{A} = 0$$

where

$$\frac{d}{dt} \int_{CV} \rho dV = 0 \quad (\text{steady flow})$$

$$\begin{aligned} \int_{CS} \rho \mathbf{u}_{rel} \cdot d\mathbf{A} &= -\rho U_\infty h b + \int_{y=0}^{y=\delta} \rho U_\infty \left[2 \frac{y}{\delta} - \frac{y^2}{\delta^2} \right] dy b = -\rho U_\infty h b + \rho U_\infty \left(\delta - \frac{1}{3} \delta \right) b \\ &= -\rho U_\infty h b + \frac{2}{3} \rho U_\infty \delta b \end{aligned}$$

(Note that there is no flow across the streamline.)

Substitute into conservation of mass and solve for h .

$$\boxed{h = \frac{2}{3} \delta} \tag{1}$$

Now apply the linear momentum equation in the x -direction on the same control volume.

$$\frac{d}{dt} \int_{CV} u \rho dV + \int_{CS} u (\rho \mathbf{u}_{rel} \cdot d\mathbf{A}) = F_{B,x} + F_{S,x}$$

where

$$\frac{d}{dt} \int_{CV} u \rho dV = 0 \quad (\text{steady flow})$$

$$\begin{aligned} \int_{CS} u (\rho \mathbf{u}_{rel} \cdot d\mathbf{A}) &= -\rho U_{\infty}^2 hb + \int_{y=0}^{y=\delta} \rho U_{\infty}^2 \left[2 \frac{y}{\delta} - \frac{y^2}{\delta^2} \right]^2 dy b \\ &= -\rho U_{\infty}^2 hb + \rho U_{\infty}^2 b \int_0^{\delta} \left[4 \frac{y^2}{\delta^2} - 4 \frac{y^3}{\delta^3} + \frac{y^4}{\delta^4} \right] dy \\ &= -\rho U_{\infty}^2 hb + \rho U_{\infty}^2 b \left[\frac{4}{3} \delta - \delta + \frac{1}{5} \delta \right] \\ &= -\rho U_{\infty}^2 hb + \frac{8}{15} \rho U_{\infty}^2 b \delta \end{aligned}$$

$$F_{B,x} = 0$$

$$F_{S,x} = -F \quad (\text{the pressure everywhere is } p_{\infty})$$

Substitute and simplify, making use of Eqn. (1).

$$-\rho U_{\infty}^2 \left(\frac{2}{3} \delta \right) b + \frac{8}{15} \rho U_{\infty}^2 b \delta = -F$$

$$\boxed{F = \frac{2}{15} \rho U_{\infty}^2 b \delta}$$

(2)

We could have also determined the force using a different control volume as shown below.

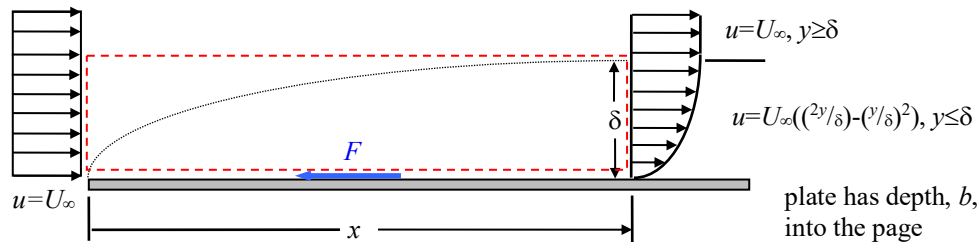

Determine the mass flow rate out of the control volume through the top using conservation of mass.

$$\frac{d}{dt} \int_{CV} \rho dV + \int_{CS} \rho \mathbf{u}_{rel} \cdot d\mathbf{A} = 0$$

where

$$\frac{d}{dt} \int_{CV} \rho dV = 0 \quad (\text{steady flow})$$

$$\int_{CS} \rho \mathbf{u}_{rel} \cdot d\mathbf{A} = -\rho U_{\infty} \delta b + \int_{y=0}^{y=\delta} \rho U_{\infty} \left[2 \frac{y}{\delta} - \frac{y^2}{\delta^2} \right] dy b + \dot{m}_{top} = -\frac{1}{3} \rho U_{\infty} \delta b + \dot{m}_{top}$$

Substitute and solve for the mass flow rate.

$$\dot{m}_{top} = \frac{1}{3} \rho U_{\infty} \delta b$$

(3)

Now apply the linear momentum equation in the x -direction to the same control volume.

$$\frac{d}{dt} \int_{CV} u \rho dV + \int_{CS} u (\rho \mathbf{u}_{rel} \cdot d\mathbf{A}) = F_{B,x} + F_{S,x}$$

where

$$\frac{d}{dt} \int_{CV} u \rho dV = 0 \quad (\text{steady flow})$$

$$\begin{aligned} \int_{CS} u (\rho \mathbf{u}_{rel} \cdot d\mathbf{A}) &= -\rho U_{\infty}^2 \delta b + \int_{y=0}^{y=\delta} \rho U_{\infty}^2 \left[2 \frac{y}{\delta} - \frac{y^2}{\delta^2} \right]^2 dy b + \dot{m}_{top} U_{\infty} \\ &= -\frac{7}{15} \rho U_{\infty}^2 \delta b + \dot{m}_{top} U_{\infty} \end{aligned}$$

(Note that the horizontal component of the velocity at the top is U_{∞} since it's outside of the boundary layer.)

$$F_{B,x} = 0$$

$$F_{S,x} = -F \quad (\text{the pressure everywhere is } p_{\infty})$$

Substitute and simplify making use of Eqn. (3).

$$-\frac{7}{15} \rho U_{\infty}^2 \delta b + \left(\frac{1}{3} \rho U_{\infty} \delta b \right) U_{\infty} = -F$$

$$F = \frac{2}{15} \rho U_{\infty}^2 \delta b \quad (\text{This is the same answer as before!})$$

Wake surveys are made in the two-dimensional wake behind a cylindrical body which is externally supported in a uniform stream of incompressible fluid approaching the cylinder with velocity, U .

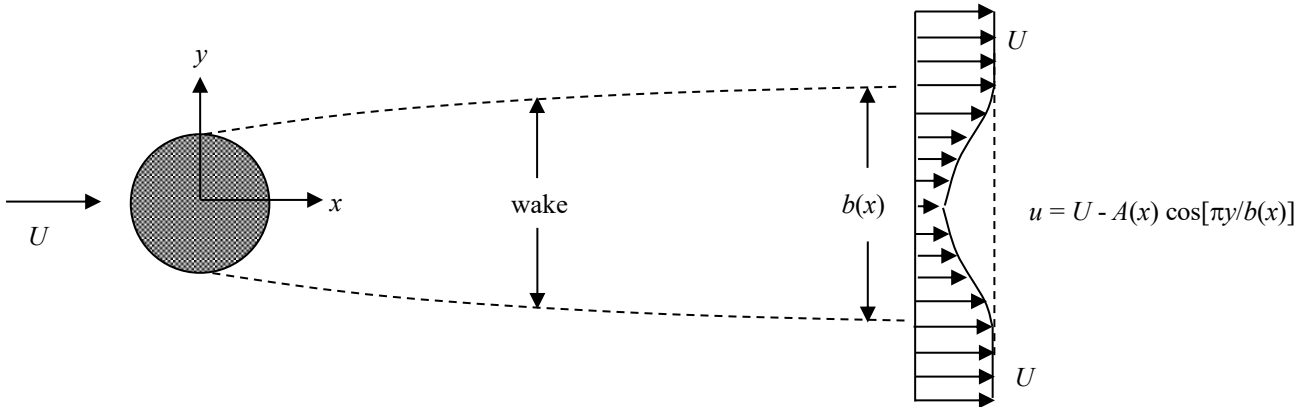

The surveys are made at x locations sufficiently far downstream of the body so that the pressure across the wake is the same as the ambient pressure in the fluid far from the body. The surveys indicate that, to a first approximation, the velocity in the wake varies with lateral position, y , according to:

$$\frac{u}{U} = 1 - \frac{A(x)}{U} \cos \left[\pi \frac{y}{b(x)} \right] \quad \text{where} \quad -\frac{1}{2} < \frac{y}{b(x)} < +\frac{1}{2}$$

The quantities $A(x)$ and $b(x)$ are the centerline velocity defect and wake width, respectively, both of which vary with position, x . If the drag on the body per unit distance normal to the plane of the sketch is denoted by D and the density of the fluid by ρ , find the relation for $b(x)$ in terms of $A(x)$, U , ρ , and D .

BRIEF SOLUTION:

1. First apply the linear momentum equation to determine a relation between the various quantities. Use a control volume that surrounds the cylinder, crosses the flow perpendicularly far upstream of the cylinder where the velocity is uniform (call this cross stream distance, h), crosses the flow perpendicularly downstream of the cylinder where the wake width is $b(x)$, and follows streamlines between the upstream to downstream locations along the sides of the control volume. Note that there is no flow across a streamline. Be sure to include the force the cylinder exerts on the control volume.
2. Apply conservation of mass to the same control volume described above to relate the upstream cross flow width, h , to the downstream cross flow width, $b(x)$.

DETAILED SOLUTION:

Apply linear momentum equation in the x -direction to the control volume shown below. Use the fixed frame of reference indicated in the figure. Note that there is no flow across a streamline.

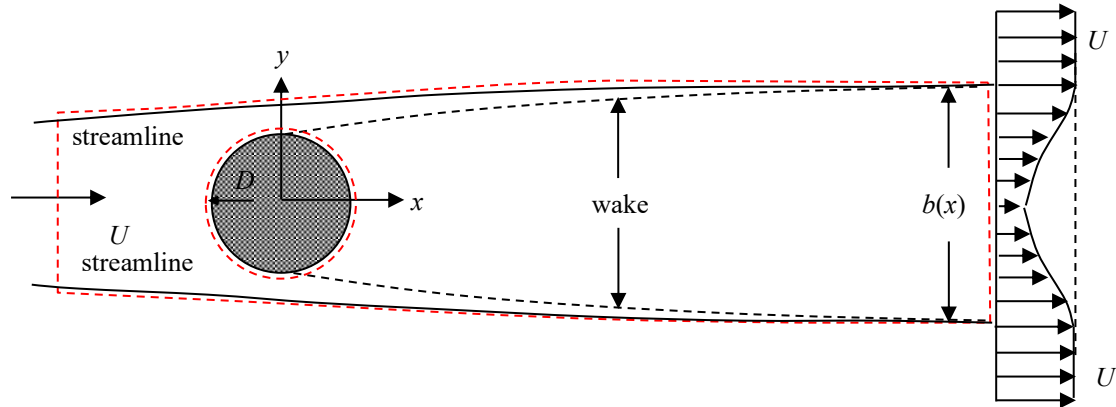

$$\frac{d}{dt} \int_{CV} u_x \rho dV + \int_{CS} u_x (\rho \mathbf{u}_{rel} \cdot d\mathbf{A}) = F_{B,x} + F_{S,x} \quad (1)$$

where

$$\frac{d}{dt} \int_{CV} u_x \rho dV = 0 \quad (\text{steady flow})$$

$$\begin{aligned} \int_{CS} u_x (\rho \mathbf{u}_{rel} \cdot d\mathbf{A}) &= U(-\rho U h) + \int_{y=-\frac{1}{2}b}^{y=+\frac{1}{2}b} u \rho u dy \\ &= -\rho U^2 h + \rho U^2 \int_{y=-\frac{1}{2}b}^{y=+\frac{1}{2}b} \left[1 - \frac{A}{U} \cos\left(\pi \frac{y}{b}\right) \right]^2 dy \\ &= -\rho U^2 h + \rho U^2 \int_{y=-\frac{1}{2}b}^{y=+\frac{1}{2}b} \left[1 - \frac{2A}{U} \cos\left(\pi \frac{y}{b}\right) + \frac{A^2}{U^2} \cos^2\left(\pi \frac{y}{b}\right) \right] dy \\ &= -\rho U^2 h + \rho U^2 \left[\underbrace{b - \frac{2Ab}{\pi U} \sin\left(\pi \frac{y}{b}\right)}_{=\frac{4Ab}{\pi U}} \Big|_{-\frac{1}{2}b}^{+\frac{1}{2}b} + \frac{bA^2}{\pi U^2} \left\{ \underbrace{\frac{\pi y}{2b}}_{=\pi/2} \Big|_{-\frac{1}{2}b}^{+\frac{1}{2}b} + \underbrace{\frac{1}{4} \sin\left(2\pi \frac{y}{b}\right)}_{=0} \Big|_{-\frac{1}{2}b}^{+\frac{1}{2}b} \right\} \right] \\ &= -\rho U^2 h + \rho U^2 \left[b - \frac{4Ab}{\pi U} + \frac{bA^2}{2U^2} \right] \\ &= \rho U^2 \left[-h + b - \frac{4Ab}{\pi U} + \frac{bA^2}{2U^2} \right] \end{aligned}$$

$$F_{B,x} = 0 \quad (\text{no body forces in the } x \text{ direction})$$

$$F_{S,x} = -D \quad (\text{no pressure forces in the } x \text{ direction})$$

Substitute and simplify.

$$\rho U^2 \left[-h + b - \frac{4Ab}{\pi U} + \frac{bA^2}{2U^2} \right] = -D \quad (2)$$

Now apply conservation of mass to the same control volume.

$$\frac{d}{dt} \int_{CV} \rho dV + \int_{CS} \rho \mathbf{u}_{rel} \cdot d\mathbf{A} = 0 \quad (3)$$

where

$$\frac{d}{dt} \int_{CV} \rho dV = 0 \quad (\text{steady flow})$$

$$\begin{aligned} \int_{CS} \rho \mathbf{u}_{rel} \cdot d\mathbf{A} &= -\rho U h + \int_{y=-\frac{1}{2}b}^{y=+\frac{1}{2}b} \rho u dy \\ &= -\rho U h + \rho U \int_{y=-\frac{1}{2}b}^{y=+\frac{1}{2}b} \left[1 - \frac{A}{U} \cos\left(\pi \frac{y}{b}\right) \right] dy \\ &= -\rho U h + \rho U \left[b - \frac{bA}{\pi U} \sin\left(\pi \frac{y}{b}\right) \right]_{-\frac{1}{2}b}^{+\frac{1}{2}b} \\ &= -\rho U h + \rho U b \left[1 - \frac{2A}{\pi U} \right] \end{aligned}$$

Substitute and simplify.

$$\begin{aligned} 0 &= -\rho U h + \rho U b \left[1 - \frac{2A}{\pi U} \right] \\ h &= b \left[1 - \frac{2A}{\pi U} \right] \quad (4) \end{aligned}$$

Substitute Eqn. (4) into Eqn. (2) and solve for $b(x)$.

$$\begin{aligned} \rho U^2 \left[-b \left(1 - \frac{2A}{\pi U} \right) + b - \frac{4Ab}{\pi U} + \frac{bA^2}{2U^2} \right] &= -D \\ \therefore b(x) &= \frac{D}{\rho U^2 A(x) \left[\frac{2}{\pi U} - \frac{A(x)}{2U^2} \right]} \quad (5) \end{aligned}$$

The rectangular control volume shown below could also have used. Note that there will be some mass flow rate through the sides as indicated in the figure below (since the upstream mass flux is larger than the downstream mass flux). The horizontal velocity through the sides will be U everywhere since the boundaries are outside the wake.

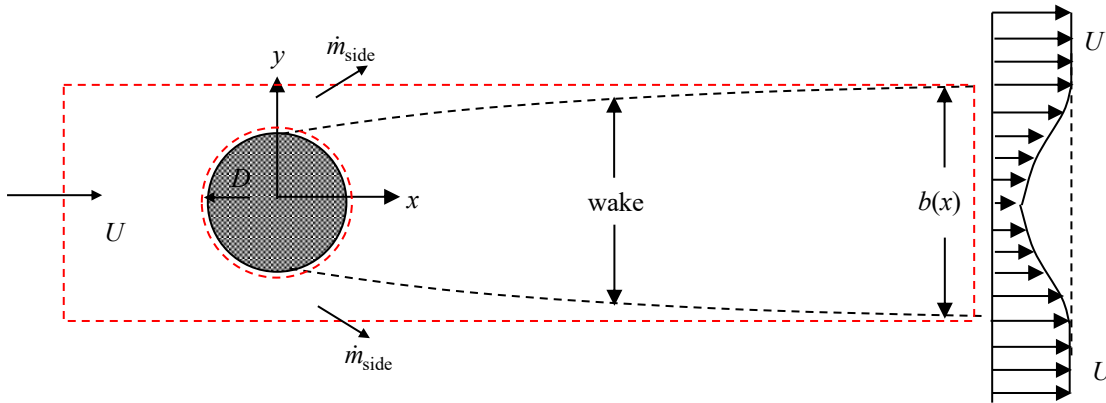

The linear momentum equation in the x -direction is:

$$\frac{d}{dt} \int_{CV} u_x \rho dV + \int_{CS} u_x (\rho \mathbf{u}_{rel} \cdot d\mathbf{A}) = F_{B,x} + F_{S,x} \quad (6)$$

where

$$\frac{d}{dt} \int_{CV} u_x \rho dV = 0 \quad (\text{steady flow})$$

$$\begin{aligned} \int_{CS} u_x (\rho \mathbf{u}_{rel} \cdot d\mathbf{A}) &= U(-\rho U b) + \int_{y=-\frac{1}{2}b}^{y=+\frac{1}{2}b} u \rho u dy + 2\dot{m}_{side} U \\ &= \rho U^2 \left[-\frac{4Ab}{\pi U} + \frac{bA^2}{2U^2} \right] + 2\dot{m}_{side} U \end{aligned}$$

$F_{B,x} = 0$ (no body forces in the x direction)

$F_{S,x} = -D$ (no pressure forces in the x direction)

Substitute and simplify.

$$\rho U^2 \left[-\frac{4Ab}{\pi U} + \frac{bA^2}{2U^2} \right] + 2\dot{m}_{side} U = -D \quad (7)$$

Now apply conservation of mass to the same control volume.

$$\frac{d}{dt} \int_{CV} \rho dV + \int_{CS} \rho \mathbf{u}_{rel} \cdot d\mathbf{A} = 0 \quad (8)$$

where

$$\frac{d}{dt} \int_{CV} \rho dV = 0 \quad (\text{steady flow})$$

$$\begin{aligned}
 \int_{\text{CS}} \rho \mathbf{u}_{\text{rel}} \cdot d\mathbf{A} &= -\rho U b + \int_{y=-\frac{1}{2}b}^{y=+\frac{1}{2}b} \rho u dy + 2\dot{m}_{\text{side}} \\
 &= -\rho U b + \rho U b \left[1 - \frac{2A}{\pi U} \right] + 2\dot{m}_{\text{side}} \\
 &= -\rho b \frac{2A}{\pi} + 2\dot{m}_{\text{side}}
 \end{aligned}$$

Substitute and simplify.

$$0 = -\rho b \frac{2A}{\pi} + 2\dot{m}_{\text{side}}$$

$$\dot{m}_{\text{side}} = \frac{\rho b A}{\pi} \tag{9}$$

Substitute Eqn. (9) into Eqn. (7) and solve for $b(x)$.

$$\therefore b(x) = \frac{D}{\rho U^2 A(x) \left[\frac{2}{\pi U} - \frac{A(x)}{2U^2} \right]} \quad (\text{This is the same result as before!}) \tag{10}$$

A hydraulic jump is a sudden increase in the depth of a liquid stream (which in this case we assume is flowing over a horizontal stream bed with atmospheric pressure air everywhere above the liquid):

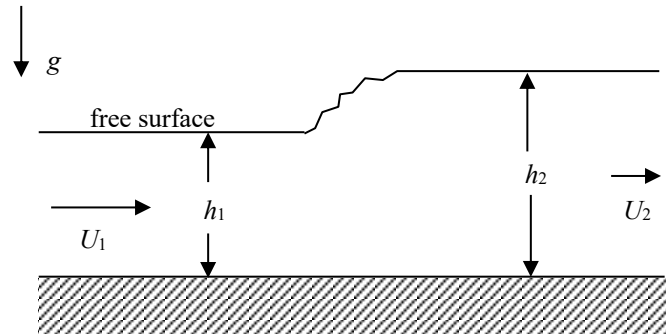

The depth increases suddenly from h_1 to h_2 downstream of the jump. The jump itself is often turbulent and involves viscous losses so that the total pressure downstream is less than that of the upstream flow.

- Find the ratio of the depths, h_2/h_1 , in terms of the upstream velocity, U_1 , the depth, h_1 , and g , the acceleration due to gravity. Assume the flows upstream and downstream have uniform velocity parallel to the stream bed and that the shear stress between the liquid and the stream bed is zero. The liquid is incompressible.
- What inequality on the value of $U_1^2/(gh_1)$ must hold for a hydraulic jump like this to occur?

BRIEF SOLUTION:

- Apply conservation of mass to relate the upstream and downstream depths, h_1 and h_2 , to the upstream and downstream velocities, U_1 and U_2 . Use a control volume that perpendicularly crosses the upstream and downstream flows where the velocities are uniform, follows the free surface, and is adjacent to the floor.
- Apply the linear momentum equation to the same control volume as in Step 2. Be sure to include the pressure forces acting on the upstream and downstream faces. Note that the pressure increases linearly with depth in the fluid.

DETAILED SOLUTION:

First apply conservation of mass to the fixed control volume shown below.

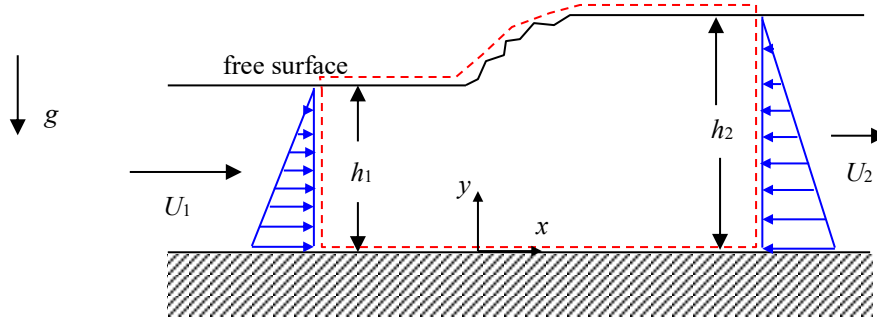

Note: Since the streamlines are parallel at the inlet and outlet of the CV, the pressure gradient normal to the streamlines will be hydrostatic.

$$\frac{d}{dt} \int_{CV} \rho dV + \int_{CS} \rho \mathbf{u}_{rel} \cdot d\mathbf{A} = 0$$

where

$$\frac{d}{dt} \int_{CV} \rho dV = 0 \quad (\text{steady flow})$$

$$\int_{CS} \rho \mathbf{u}_{rel} \cdot d\mathbf{A} = -\rho U_1 h_1 b + \rho U_2 h_2 b$$

Substitute and simplify.

$$h_2 U_2 = h_1 U_1 \tag{1}$$

Now apply conservation of linear momentum in the x -direction to the same control volume.

$$\frac{d}{dt} \int_{CV} u \rho dV + \int_{CS} u (\rho \mathbf{u}_{rel} \cdot d\mathbf{A}) = F_{B,x} + F_{S,x}$$

where

$$\frac{d}{dt} \int_{CV} u \rho dV = 0 \quad (\text{steady flow})$$

$$\int_{CS} u (\rho \mathbf{u}_{rel} \cdot d\mathbf{A}) = -\rho U_1^2 h_1 b + \rho U_2^2 h_2 b$$

$$F_{B,x} = 0$$

$$F_{S,x} = \int_{y=0}^{y=h_1} \rho g (h_1 - y) dy b - \int_{y=0}^{y=h_2} \rho g (h_2 - y) dy b = \frac{1}{2} \rho g h_1^2 b - \frac{1}{2} \rho g h_2^2 b$$

(hydrostatic pressure forces on left and right sides)

Substitute and simplify making use of Eqn. (1). Solve for the ratio h_2/h_1 .

$$-\rho U_1^2 h_1 b + \rho U_2^2 h_2 b = \frac{1}{2} \rho g h_1^2 b - \frac{1}{2} \rho g h_2^2 b$$

$$-U_1^2 h_1 + U_2^2 h_2 = \frac{1}{2} g (h_1^2 - h_2^2)$$

$$U_1^2 h_1 \left(\frac{U_2}{U_1} - 1 \right) = \frac{1}{2} g (h_1 - h_2)(h_1 + h_2) \quad (\text{using Eqn. (1)})$$

$$U_1^2 h_1 \left(\frac{h_1}{h_2} - 1 \right) = \frac{1}{2} g (h_1 - h_2)(h_1 + h_2) \quad (\text{using Eqn. (1)})$$

$$U_1^2 h_1 \left(\frac{h_1 - h_2}{h_2} \right) = \frac{1}{2} g (h_1 - h_2)(h_1 + h_2)$$

$$U_1^2 \frac{h_1}{h_2} = \frac{1}{2} g (h_1 + h_2) \Rightarrow \frac{U_1^2}{h_2/h_1} = \frac{1}{2} g h_1 \left(1 + h_2/h_1 \right)$$

$$\frac{2U_1^2}{gh_1} = \frac{h_2/h_1}{1 + h_2/h_1} \Rightarrow \left(\frac{h_2/h_1}{1 + h_2/h_1} \right)^2 + \frac{h_2/h_1}{1 + h_2/h_1} - \frac{2U_1^2}{gh_1} = 0$$

$$\frac{h_2/h_1}{1 + h_2/h_1} = \frac{-1 \pm \sqrt{1 + \frac{8U_1^2}{gh_1}}}{2}$$

We can neglect the negative sign in front of the second term since it is unrealistic.

$$\boxed{\therefore \frac{h_2}{h_1} = -\frac{1}{2} + \sqrt{\frac{1}{4} + \frac{2U_1^2}{gh_1}}} \quad (2)$$

For the hydraulic jump to occur, we need $h_2/h_1 > 1$.

$$1 < -\frac{1}{2} + \sqrt{\frac{1}{4} + \frac{2U_1^2}{gh_1}} \Rightarrow \boxed{\frac{U_1^2}{gh_1} > 1} \quad (3)$$

The dimensionless parameter in Eqn. (3) is the square of the flow's Froude number, Fr.

$$\text{Fr} \equiv \frac{U_1}{\sqrt{gh_1}} \quad (4)$$

where $\text{Fr} < 1$ is referred to as subcritical flow, $\text{Fr} = 1$ is critical flow, and $\text{Fr} > 1$ is supercritical flow. For the hydraulic jump to occur, we must have supercritical flow, *i.e.* $\text{Fr} > 1$.

In an attempt to model the speed of a tsunami wave in the deep ocean, consider the propagation of a small amplitude, solitary wave front moving with speed, c , from right to left as shown in the figure below. Neglect the effects of surface tension. The liquid is initially at rest but after the wave passes by, the fluid behind the wave has a small velocity, dV , in the same direction as the wave.

Derive an expression for the wave speed, c . You may neglect the shear forces the channel bed and the atmosphere exert on the liquid. Hint: Consider choosing a steady frame of reference when analyzing the problem.

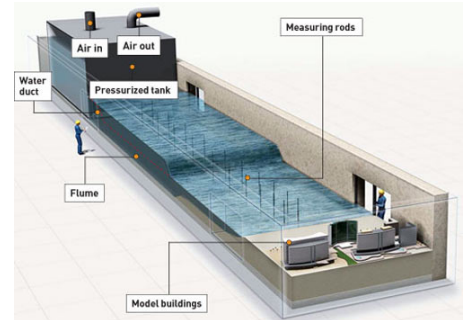
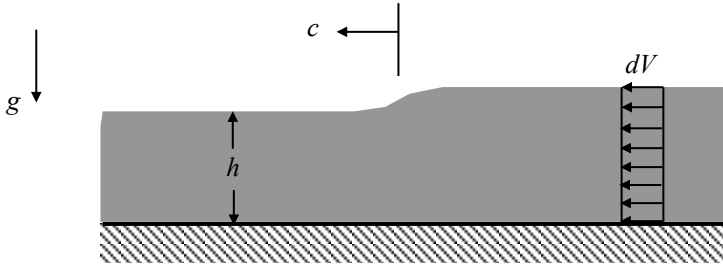

BRIEF SOLUTION:

1. Use a frame of reference fixed to the wave so that the flow appears steady.
2. Apply the linear momentum equation using a control volume that is perpendicular to the upstream and downstream flows where the velocities are uniform, along the bottom of the channel, and along the free surface. Be sure to include the pressure forces on the upstream and downstream boundaries. Note that the pressure increases linearly with depth from the free surface.
3. Apply conservation of mass to the same control volume.

DETAILED SOLUTION:

Apply the linear momentum equation in the x -direction to the control volume shown below. Use a frame of reference that is fixed to the wave. Since a constant wave velocity is assumed, the frame of reference will be inertial.

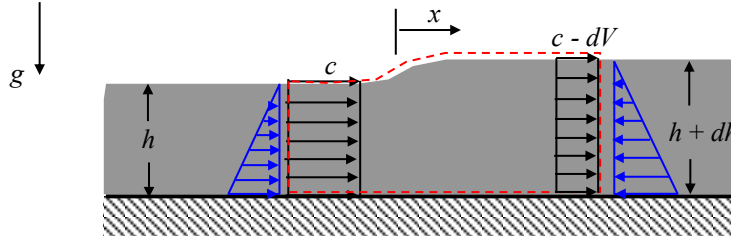

$$\frac{d}{dt} \int_{CV} u_x \rho dV + \int_{CV} u_x (\rho \mathbf{u}_{rel} \cdot d\mathbf{A}) = F_{B,x} + F_{S,x}$$

where

$$\frac{d}{dt} \int_{CV} u_x \rho dV = 0 \quad (\text{steady flow})$$

$$\int_{CV} u_x (\rho \mathbf{u}_{rel} \cdot d\mathbf{A}) = c(-\dot{m}) + (c - dV)\dot{m} = -\dot{m}dV \quad \text{where } \dot{m} = \rho ch$$

$$F_{B,x} = 0$$

$$F_{S,x} = \frac{1}{2} \rho gh^2 - \frac{1}{2} \rho g (h + dh)^2 = -\rho gh dh - \underbrace{\frac{1}{2} \rho g dh^2}_{H.O.T.} = -\rho gh dh$$

Substitute and simplify.

$$-\rho ch dV = -\rho gh dh$$

$$cdV = gh$$

(1)

Apply conservation of mass to the same control volume.

$$\frac{d}{dt} \int_{CV} \rho dV + \int_{CV} \rho \mathbf{u}_{rel} \cdot d\mathbf{A} = 0$$

where

$$\frac{d}{dt} \int_{CV} \rho dV = 0 \quad (\text{steady flow})$$

$$\int_{CV} \rho \mathbf{u}_{rel} \cdot d\mathbf{A} = -\rho ch + \rho (c - dV)(h + dh) = -\rho ch + \rho ch + \rho cdh - \rho hdV - \underbrace{\rho dV dh}_{=H.O.T.}$$

$$= \rho cdh - \rho hdV$$

Substitute and simplify.

$$\rho cdh - \rho hdV = 0 \Rightarrow cdh = hdV$$

$$dh = \frac{hdV}{c}$$

(2)

Substitute Eqn. (2) into Eqn. (1) and simplify.

$$cdV = g \frac{hdV}{c}$$

$$\boxed{\therefore c = \sqrt{gh}}$$

(3)

As an example, consider the speed of a traveling wave in the deep ocean resulting from an undersea earthquake for example (the wave amplitude is small compared to its wavelength). Assuming an ocean depth of 1610 m (1 mile), the speed of the wave will be 126 m/s (280 mph)!

Two parallel plates of width, $2a$, (and unit depth) are separated by a gap of height, h , which changes with time. The upper plate approaches the lower plate at a constant speed, V . The space between the plates is filled with a frictionless, incompressible gas of density, ρ . Assume that the velocity is uniform across the gap width (y direction) so that $u=u(x, t)$.

Obtain algebraic expressions for:

- the velocity distribution, $u(x, t)$.
- the pressure distribution in the gap, $p(x, t)$. The pressure outside of the gap is atmospheric pressure. Note: You do not need to use Bernoulli's equation to solve this problem.

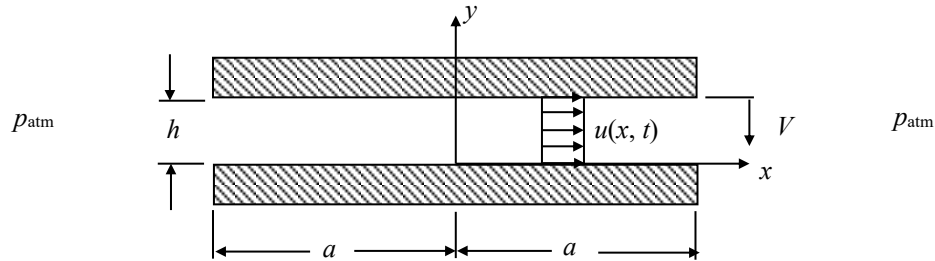

SOLUTION:

Apply conservation of mass to the control volume shown below.

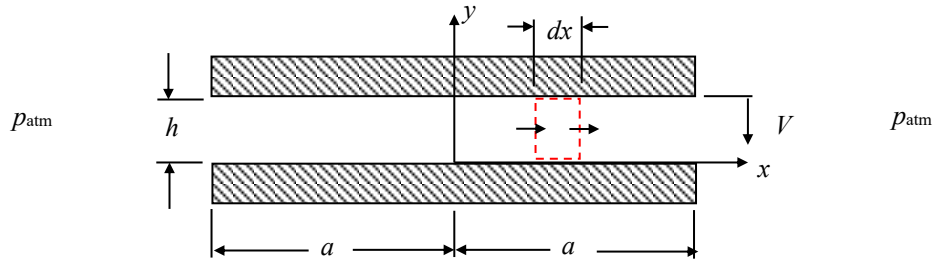

$$\frac{d}{dt} \int_{CV} \rho dV + \int_{CS} \rho \mathbf{u}_{rel} \cdot d\mathbf{A} = 0$$

where

$$\frac{d}{dt} \int_{CV} \rho dV = \frac{d}{dt} (\rho h dx) = \rho \frac{dh}{dt} dx = -\rho V dx \tag{1}$$

$$\int_{CS} \rho \mathbf{u}_{rel} \cdot d\mathbf{A} = - \left[(\rho u h) + \frac{\partial}{\partial x} (\rho u h) \left(-\frac{1}{2} dx\right) \right] + \left[(\rho u h) + \frac{\partial}{\partial x} (\rho u h) \left(\frac{1}{2} dx\right) \right] \tag{2}$$

$$= \frac{\partial}{\partial x} (\rho u h) dx = \rho \frac{\partial u}{\partial x} h dx$$

Substitute and simplify.

$$-\rho V dx + \rho \frac{\partial u}{\partial x} h dx = 0$$

$$\frac{\partial u}{\partial x} = \frac{V}{h}$$

$$u = V \frac{x}{h} + f(t) \text{ where } f(t) \text{ is an unknown function of time (Note: } u = u(x, t).)$$

Since the velocity at the center line of the plate is always zero, i.e. $u(x = 0, t) = 0$, then $f(t) = 0$.

$$\boxed{\therefore u = V \frac{x}{h}} \text{ (Note: } h = h(t) \Rightarrow u = u(x, t).) \tag{3}$$

Now apply the linear momentum equation in the x -direction to the same control volume using the given fixed frame of reference.

$$\frac{d}{dt} \int_{CV} u_x \rho dV + \int_{CS} u_x (\rho \mathbf{u}_{rel} \cdot d\mathbf{A}) = F_{B,x} + F_{S,x}$$

where

$$\frac{d}{dt} \int_{CV} u_x \rho dV = \frac{d}{dt} (u \rho h dx) = \rho dx \left(u \frac{dh}{dt} + h \frac{\partial u}{\partial t} \right) = \rho dx \left(-uV + h \frac{\partial u}{\partial t} \right) \quad (4)$$

$$\begin{aligned} \int_{CS} u_x (\rho \mathbf{u}_{rel} \cdot d\mathbf{A}) &= - \left[(u \rho u h) + \frac{\partial}{\partial x} (u \rho u h) \left(-\frac{1}{2} dx \right) \right] + \left[(u \rho u h) + \frac{\partial}{\partial x} (u \rho u h) \left(\frac{1}{2} dx \right) \right] \\ &= \frac{\partial}{\partial x} (u \rho u h) dx = 2 \rho u \frac{\partial u}{\partial x} h dx \end{aligned} \quad (5)$$

$$F_{B,x} = 0 \quad (6)$$

$$\begin{aligned} F_{S,x} &= \left[(ph) + \frac{\partial}{\partial x} (ph) \left(-\frac{1}{2} dx \right) \right] - \left[(ph) + \frac{\partial}{\partial x} (ph) \left(\frac{1}{2} dx \right) \right] \\ &= - \frac{\partial}{\partial x} (ph) dx = - \frac{\partial p}{\partial x} h dx \end{aligned} \quad (7)$$

Substitute and simplify.

$$\rho dx \left(-uV + h \frac{\partial u}{\partial t} \right) + 2 \rho u \frac{\partial u}{\partial x} h dx = - \frac{\partial p}{\partial x} h dx \quad (8)$$

Substitute for u using the expression derived from conservation of mass.

$$\left[- \left(V \frac{x}{h} \right) V + h \left(V^2 \frac{x}{h^2} \right) \right] + 2 \left(V \frac{x}{h} \right) \left(V \frac{1}{h} \right) h = - \frac{1}{\rho} \frac{\partial p}{\partial x} h \quad (9)$$

$$2V^2 \frac{x}{h} = - \frac{1}{\rho} \frac{\partial p}{\partial x} h$$

$$\frac{\partial p}{\partial x} = -2\rho V^2 \frac{x}{h^2}$$

$$p = -\rho V^2 \frac{x^2}{h^2} + f(t) \quad (10)$$

The pressure at $x = a$ is p_{atm} for all times, *i.e.* $p(x = a, t) = p_{atm}$:

$$p_{atm} = -\rho V^2 \frac{a^2}{h^2} + f(t) \Rightarrow f(t) = p_{atm} + \rho V^2 \frac{a^2}{h^2} \quad (11)$$

Substituting and simplifying gives:

$$p = -\rho V^2 \frac{x^2}{h^2} + p_{atm} + \rho V^2 \frac{a^2}{h^2}$$

$$\boxed{\frac{p - p_{atm}}{\frac{1}{2} \rho V^2} = 2 \left[\left(\frac{a}{h} \right)^2 - \left(\frac{x}{h} \right)^2 \right]} \quad (\text{Note: } h = h(t) \Rightarrow p = p(x, t).) \quad (12)$$

Now let's work the problem using the control volume shown below.

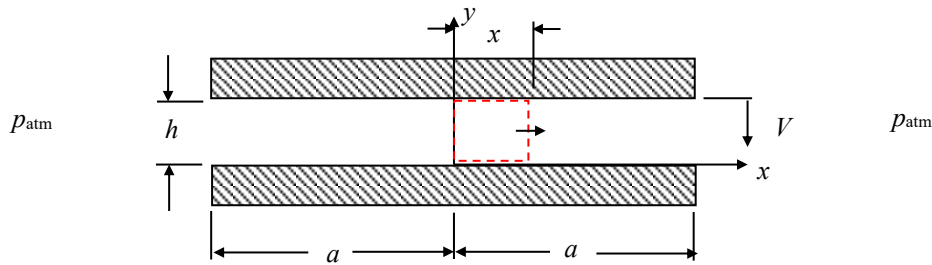

Conservation of Mass:

$$\frac{d}{dt} \int_{CV} \rho dV + \int_{CS} \rho \mathbf{u}_{rel} \cdot d\mathbf{A} = 0$$

where

$$\frac{d}{dt} \int_{CV} \rho dV = \frac{d}{dt} [\rho h x] = \rho \frac{dh}{dt} x = -\rho V x \quad (13)$$

$$\int_{CS} \rho \mathbf{u}_{rel} \cdot d\mathbf{A} = \rho u h \quad (\text{Mass flux only through right side due to symmetry.}) \quad (14)$$

Substitute and simplify.

$$-\rho V x + \rho u h = 0$$

$$\boxed{u = V \left(\frac{x}{h} \right)} \quad \text{This is the same result as before!} \quad (15)$$

Linear Momentum Equation in the x-direction:

$$\frac{d}{dt} \int_{CV} u_x \rho dV + \int_{CS} u_x (\rho \mathbf{u}_{rel} \cdot d\mathbf{A}) = F_{B,x} + F_{S,x}$$

where

$$\frac{d}{dt} \int_{CV} u_x \rho dV = \frac{d}{dt} \int_{x=0}^{x=x} \rho u h dx = \frac{d}{dt} \int_{x=0}^{x=x} \rho \left(V \frac{x}{h} \right) h dx = \rho V \frac{d}{dt} \left(\int_{x=0}^{x=x} x dx \right) = 0 \quad (16)$$

(The result from conservation of mass has been used in simplifying the previous expression.)

$$\int_{CS} u_x (\rho \mathbf{u}_{rel} \cdot d\mathbf{A}) = \rho u^2 h = \rho V^2 \frac{x^2}{h} \quad (\text{Momentum flux only through right side due to symmetry.}) \quad (17)$$

(The result from conservation of mass has been used in simplifying the previous expression.)

$$F_{B,x} = 0 \quad (18)$$

$$F_{S,x} = p_{x=0} h - p_{x=x} h \quad (19)$$

Substitute and simplify.

$$\rho V^2 \frac{x^2}{h} = p_{x=0} h - p_{x=x} h$$

$$p_{x=x} = p_{x=0} - \rho V^2 \frac{x^2}{h^2} \quad (20)$$

Since the pressure at $x = a$ is p_{atm} , i.e. $p(x = a, t) = p_{atm}$:

$$p_{atm} = p_{x=0} - \rho V^2 \frac{a^2}{h^2} \Rightarrow p_{x=0} = p_{atm} + \rho V^2 \frac{a^2}{h^2} \quad (21)$$

$$p_{x=x} = p_{atm} + \rho V^2 \frac{a^2}{h^2} - \rho V^2 \frac{x^2}{h^2}$$

$$\boxed{\therefore \frac{p - p_{atm}}{\frac{1}{2} \rho V^2} = 2 \left[\left(\frac{a}{h} \right)^2 - \left(\frac{x}{h} \right)^2 \right]} \quad \text{This is the same result as before!} \quad (22)$$

Note that since $a > x$, $(p - p_{\text{atm}}) > 0$. Thus, a downward force must be applied to move the top plate downward. Furthermore, as h decreases, this force increases since $(p - p_{\text{atm}})$ increases.

A weir discharges into a channel of constant breadth as shown in the figure. It is observed that a region of still water backs up behind the jet to a height a . The velocity and height of the flow in the channel are given as V and h , respectively, and the density of the water is ρ . You may assume that friction and the horizontal momentum of the fluid falling over the weir are negligible.

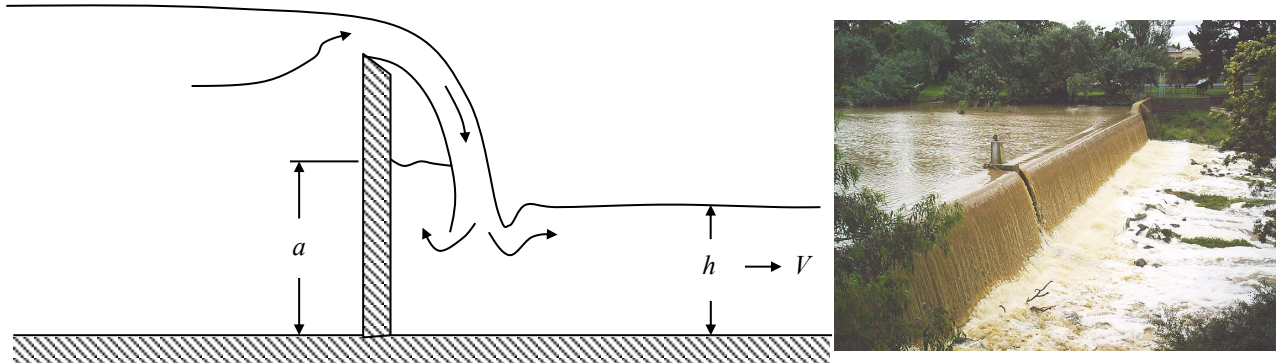

What is the height a in terms of the other parameters?

SOLUTION:

Apply the linear momentum equation in the x -direction to the control volume shown below. Use the fixed frame of reference shown in the figure.

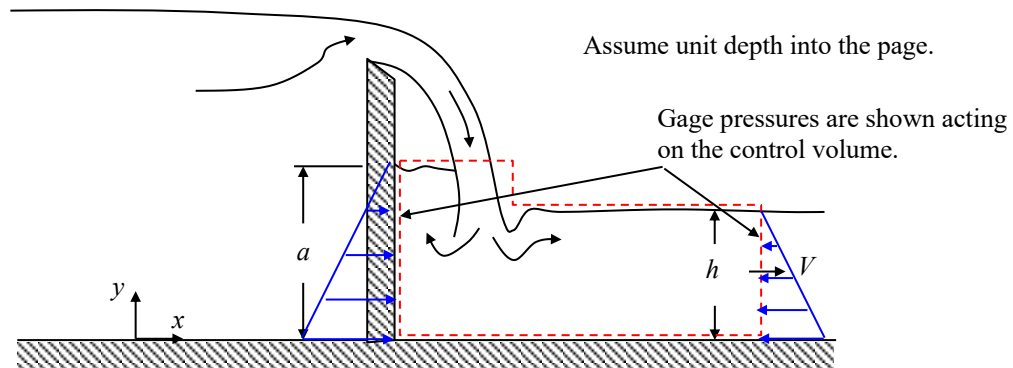

$$\frac{d}{dt} \int_{CV} u_x \rho dV + \int_{CS} u_x (\rho \mathbf{u}_{rel} \cdot d\mathbf{A}) = F_{B,x} + F_{S,x}$$

where

$$\frac{d}{dt} \int_{CV} u_x \rho dV = 0 \quad (\text{steady flow})$$

$$\int_{CS} u_x (\rho \mathbf{u}_{rel} \cdot d\mathbf{A}) = \rho V^2 h \quad (\text{assume incoming flow has negligible horizontal velocity})$$

$$F_{B,x} = 0$$

$$F_{S,x} = \frac{1}{2} \rho g a^2 - \frac{1}{2} \rho g h^2 \quad (\text{net horizontal pressure forces})$$

Substitute and simplify.

$$\rho V^2 h = \frac{1}{2} \rho g a^2 - \frac{1}{2} \rho g h^2 \quad (1)$$

$$a^2 = h^2 + \frac{2V^2 h}{g}$$

$$a = h \sqrt{1 + \frac{2V^2}{gh}}$$

$$\boxed{\therefore \frac{a}{h} = \sqrt{1 + 2\text{Fr}^2}} \quad (2)$$

where $\text{Fr} = V/(gh)^{1/2}$ is a dimensionless parameter known as the Froude number.