

2.3. Pressure Forces on Submerged Surfaces and Center of Pressure

2.3.1. Flat Surfaces

Recall from Chapter 1 that the small pressure force $d\mathbf{F}_p$ acting on a surface with a small area $d\mathbf{A}$ is,

$$d\mathbf{F}_p = p(-d\mathbf{A}). \quad (2.30)$$

This force relationship was written specifically for a differentially small area since it's possible that over a large area, the pressure and the direction of the area could vary over the area (Figure 2.7). Thus, to find the total pressure force on the whole area, the (small) force on a small area, where the area direction and pressure are well defined, is calculated first and then these are added, or integrated, over the whole area, i.e.,

$$\mathbf{F}_P = \int_A d\mathbf{F}_p = \int_A p(-d\mathbf{A}). \quad (2.31)$$

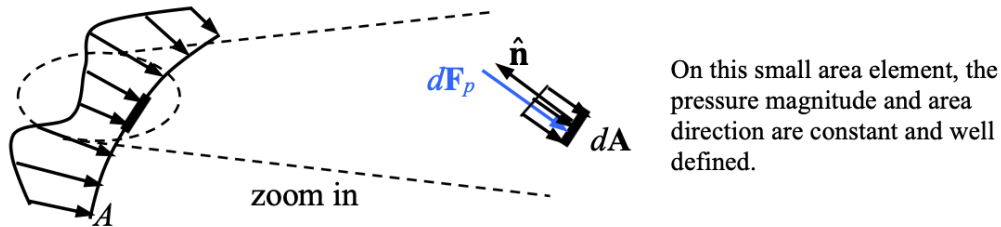

FIGURE 2.7. A sketch showing how the pressure magnitude and area orientation may change over a large area. However, over a differentially-small area, both the pressure and surface orientation are well defined.

Let's consider the example of a fish tank completely filled with water, as shown in Figure 2.8. We wish to determine the net pressure force acting on bottom and right tank walls. Start first with the pressure force

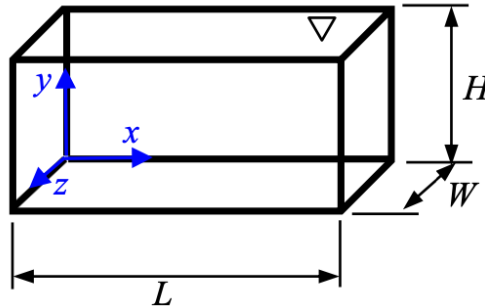

FIGURE 2.8. A completely-filled fish tank used in the example.

on the tank bottom, (Figure 2.9),

$$\mathbf{F}_{p,\text{bottom}} = \int_{z=0}^{z=W} \int_{x=0}^{x=L} p \underbrace{[-dx dz \hat{\mathbf{j}}]}_{=-d\mathbf{A}} = -\hat{\mathbf{j}} \int_{z=0}^{z=W} \int_{x=0}^{x=L} \underbrace{\rho g H}_{=p_{\text{gage}}} dx dz = -\hat{\mathbf{j}} \rho g H W L, \quad (2.32)$$

where, at the bottom of the tank, the gage pressure remains constant at,

$$p_{\text{bottom, gage}} = \rho g H. \quad (2.33)$$

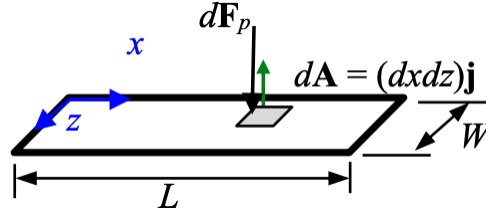

FIGURE 2.9. The bottom surface of the fish tank.

Notes:

- (1) The magnitude of the pressure force on the bottom is equal to the weight of the water in the tank. This makes sense because if there are no shear stresses at the side walls, then the pressure force at the bottom of the tank must support all of the weight of the liquid sitting above it.
- (2) A gage pressure is used in Eq. (2.32) to simplify the pressure force calculation. Since there is atmosphere on the other side of the tank bottom, then the gage pressure due to the atmosphere is zero ($p_{\text{atm,gage}} = 0$) and the corresponding pressure force is zero. We get the same result as Eq. (2.32) if absolute pressures are used everywhere instead,

$$\mathbf{F}_{p,\text{bottom}} = \underbrace{\int_{z=0}^{z=W} \int_{x=0}^{x=L} (p_{\text{atm}} + \rho g H) (-dx dz \hat{\mathbf{j}})}_{\text{pressure force due to water using an absolute pressure}} + \underbrace{\int_{z=0}^{z=W} \int_{x=0}^{x=L} (p_{\text{atm}}) (dx dz \hat{\mathbf{j}})}_{\text{pressure force due to atmosphere using an absolute pressure}} = -\hat{\mathbf{j}} \rho g H W L. \quad (2.34)$$

Note that the unit normal vector for the atmospheric side (bottom side, second integral) is in the opposite direction of the unit normal vector for the water side (first integral) since we're on opposite sides of the wall.

- (3) Since the pressure and the area orientation don't vary over the bottom surface, we could have also found the pressure force on the bottom of the tank using,

$$\mathbf{F}_{p,\text{bottom}} = p(-\mathbf{A}) = \rho g H (-W L \hat{\mathbf{j}}). \quad (2.35)$$

It's important to emphasize that we can only avoid integration if both the pressure and area orientation are constant on the macroscopic area.

Now let's calculate the pressure force acting on the right side wall (Figure 2.10),

$$\mathbf{F}_{p,\text{right}} = \int_{z=0}^{z=W} \int_{y=0}^{y=H} p \underbrace{[dy dz \hat{\mathbf{i}}]}_{=-d\mathbf{A}} = \hat{\mathbf{i}} \int_{z=0}^{z=W} \int_{y=0}^{y=H} \underbrace{\rho g (H - y)}_{=p_{\text{gage}}} dy dz = \hat{\mathbf{i}} \frac{1}{2} \rho g H^2 W. \quad (2.36)$$

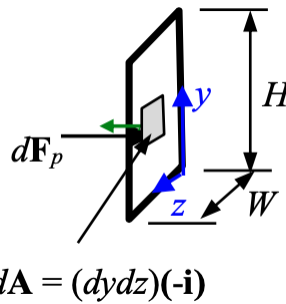

FIGURE 2.10. The right surface of the fish tank.

Notes:

- (1) Recall from the diagram that the coordinate system is located at the bottom of the tank. Thus, the (gage) pressure varies as,

$$p_{\text{gage}} = \rho g(H - y). \quad (2.37)$$

This pressure still varies linearly with depth, as shown in Figure 2.11.



FIGURE 2.11. The pressure variation with depth in the fish tank example.

- (2) The small area element $d\mathbf{A} = -dydz\hat{\mathbf{i}}$ (Figure 2.10) is used since the pressure has a well-defined value on this area. Since the pressure only varies in the y direction, we could have also used the area element $d\mathbf{A} = -Wdy\hat{\mathbf{i}}$ (Figure 2.12). The pressure is well defined on this “strip” of area too,

$$\mathbf{F}_{p,\text{right}} = \int_{y=0}^{y=H} p(-Wdy\hat{\mathbf{i}}) = \hat{\mathbf{i}}W \int_{y=0}^{y=H} \rho g(H - y)dy = \hat{\mathbf{i}}\rho g \frac{1}{2}H^2W. \quad (2.38)$$

A vertical strip of area, i.e., $d\mathbf{A} = -Hdz\hat{\mathbf{i}}$, can't be used to determine the pressure force since the pressure isn't well defined on this surface. The pressure varies in the y direction so over this vertical strip, the pressure doesn't remain constant.

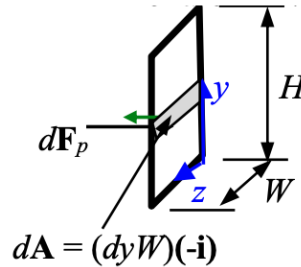

FIGURE 2.12. An alternate, and easier differential area for integrating the pressure force on the right side wall.

- (3) The pressure force is equal in magnitude to the area under the pressure curve shown in Note #1,

$$|d\mathbf{F}_p| = \frac{1}{2} \underbrace{(\rho g H)}_{\text{base}} \underbrace{(H)}_{\text{height}} \underbrace{(W)}_{\text{depth}} = \frac{1}{2}\rho g H^2 W. \quad (2.39)$$

This same behavior is true for the pressure force on the base.

Now that we've determined the resultant pressure force on the right surface, let's determine where this resultant force acts (Figure 2.13). This location is known as the center of pressure (CP). The center of pressure is found by ensuring that the moments generated by the resultant pressure force equal the moments

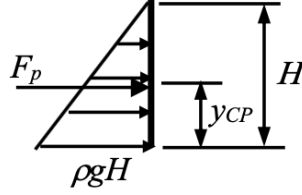

FIGURE 2.13. A sketch showing the distributed pressure forces, the resultant pressure force, and the location of the center of pressure.

generated by the actual, distributed pressure forces. Consider the right side of the tank and Figure 2.10. Balancing moments about the origin,

$$\underbrace{\mathbf{x}_{CP} \times \mathbf{F}_{p,\text{right}}}_{\text{moment due to resultant force acting at the CP}} = \int_{y=0}^{y=H} \int_{z=0}^{z=W} \underbrace{(x\hat{\mathbf{i}} + y\hat{\mathbf{j}} + z\hat{\mathbf{k}})}_{=\text{moment arm}} \times \underbrace{p(-d\mathbf{A})}_{=d\mathbf{F}_p} \quad (2.40)$$

$$(x_{CP}\hat{\mathbf{i}} + y_{CP}\hat{\mathbf{j}} + z_{CP}\hat{\mathbf{k}}) \times \left(\frac{1}{2}\rho g H^2 W \hat{\mathbf{i}} \right) = \int_0^H \int_0^W (x\hat{\mathbf{i}} + y\hat{\mathbf{j}} + z\hat{\mathbf{k}}) \times [\rho g(H-y)dzdy(\hat{\mathbf{i}})], \quad (2.41)$$

$$y_{CP} \frac{1}{2}\rho g H^2 W (-\hat{\mathbf{k}}) + z_{CP} \frac{1}{2}\rho g H^2 W (\hat{\mathbf{j}}) = \int_0^H y \rho g(H-y)W dy (-\hat{\mathbf{k}}) + \int_0^H \frac{1}{2}W^2 \rho g(H-y)dy (\hat{\mathbf{j}}), \quad (2.42)$$

$$y_{CP} \frac{1}{2}\rho g H^2 W (-\hat{\mathbf{k}}) + z_{CP} \frac{1}{2}\rho g H^2 W (\hat{\mathbf{j}}) = \frac{1}{6}\rho g H^3 W (-\hat{\mathbf{k}}) + \frac{1}{4}W^2 \rho g H^2 (\hat{\mathbf{j}}), \quad (2.43)$$

$$\therefore y_{CP} = \frac{1}{3}H \text{ and } z_{CP} = \frac{1}{2}W. \quad (2.44)$$

The center of pressure in the x direction is undefined since the resultant and distributed pressure forces act in the x direction and, thus, there is no moment generated by the forces about the x axis.

Notes:

- (1) The center of pressure is also equal to the center of area under the pressure distribution curve.
- (2) We can take moments about any location and get the same result.
- (3) The center of pressure for the right wall in the z direction may also be determined from symmetry.

For each of the following pressure profiles,

- Determine the magnitude of the total pressure force acting on the horizontal plate.
- Determine the location of the center of pressure.

Assume the plate has unit depth in the z direction. Show all of your work.

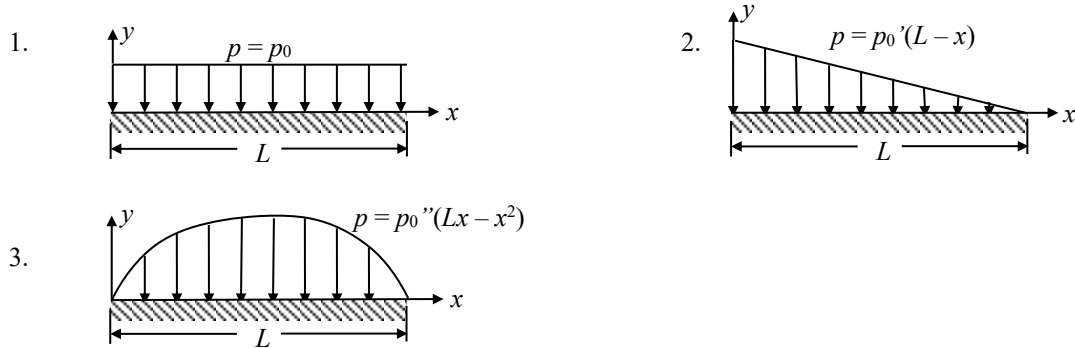

SOLUTION:

The total pressure force may be found via integration of the differential pressure force.

$$|F_p| = \int_{x=0}^{x=L} p \underbrace{dx(1)}_{=dA} \quad (\text{Note: The differential area is } dA = dx(1) \text{ since the plate has unit depth.}) \quad (1)$$

$$1. \quad |F_p| = \int_{x=0}^{x=L} p_0 dx \Rightarrow |F_p| = p_0 L \quad (2)$$

$$2. \quad |F_p| = \int_{x=0}^{x=L} p'_0(L-x) dx = p'_0 \left(L^2 - \frac{1}{2} L^2 \right) \Rightarrow |F_p| = \frac{1}{2} p'_0 L^2 \quad (3)$$

$$3. \quad |F_p| = \int_{x=0}^{x=L} p''_0(Lx - x^2) dx = p''_0 \left(\frac{1}{2} L^3 - \frac{1}{3} L^3 \right) \Rightarrow |F_p| = \frac{1}{6} p''_0 L^3 \quad (4)$$

The center of pressure may be found by equating the moment resulting from the pressure distribution to the moment caused by the total pressure force acting at the center of pressure.

$$\int_{x=0}^{x=L} xp \underbrace{dx(1)}_{=dA} = x_{CP} F_p \Rightarrow x_{CP} = \frac{1}{F_p} \int_{x=0}^{x=L} xp \underbrace{dx(1)}_{=dA} \quad (5)$$

$$1. \quad x_{CP} = \frac{1}{p_0 L} \int_{x=0}^{x=L} xp_0 dx = \frac{1}{p_0 L} \left(\frac{1}{2} p_0 L^2 \right) \Rightarrow x_{CP} = \frac{1}{2} L \quad (6)$$

$$2. \quad x_{CP} = \frac{1}{\frac{1}{2} p'_0 L^2} \int_{x=0}^{x=L} xp'_0(L-x) dx = \frac{1}{\frac{1}{2} p'_0 L^2} \left[p'_0 \left(\frac{1}{2} L^3 - \frac{1}{3} L^3 \right) \right] \Rightarrow x_{CP} = \frac{1}{3} L \quad (7)$$

$$3. \quad x_{CP} = \frac{1}{\frac{1}{6} p''_0 L^3} \int_{x=0}^{x=L} xp''_0(Lx - x^2) dx = \frac{1}{\frac{1}{6} p''_0 L^3} \left[p''_0 \left(\frac{1}{3} L^4 - \frac{1}{4} L^4 \right) \right] \Rightarrow x_{CP} = \frac{1}{2} L \quad (8)$$

Calculate the net horizontal and vertical forces acting on the planar surface shown below. The surface has a width w into the page.

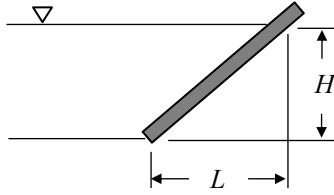

SOLUTION:

One approach to finding the net force on the wall is to integrate the pressure force along the wall,

$$\mathbf{F}_p = \int_A -p d\mathbf{A}, \quad (1)$$

where,

$$p = \rho gy, \quad (2)$$

and,

$$d\mathbf{A} = -w dy \hat{\mathbf{e}}_x - w dx \hat{\mathbf{e}}_y. \quad (3)$$

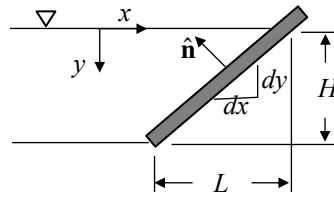

Note that since we'll be integrating in the y direction (since the pressure varies in that direction), we should express dx in terms of dy ,

$$\frac{dy}{dx} = \frac{H}{L} \Rightarrow dx = \left(\frac{L}{H}\right) dy. \quad (4)$$

Substituting and integrating as y goes from zero to H ,

$$\mathbf{F}_p = \int_{y=0}^{y=H} -(\rho gy) \left[-w dy \hat{\mathbf{e}}_x - w \left(\frac{L}{H}\right) dy \hat{\mathbf{e}}_y \right] = \rho gw \left[\hat{\mathbf{e}}_x \int_{y=0}^{y=H} y dy + \hat{\mathbf{e}}_y \left(\frac{L}{H}\right) \int_{y=0}^{y=H} y dy \right], \quad (5)$$

$$\mathbf{F}_p = \rho gw \left[\frac{1}{2} H^2 \hat{\mathbf{e}}_x + \frac{1}{2} \left(\frac{L}{H}\right) H^2 \hat{\mathbf{e}}_y \right], \quad (6)$$

$$\boxed{\mathbf{F}_p = \frac{1}{2} \rho gw H^2 \hat{\mathbf{e}}_x + \frac{1}{2} \rho gw LH \hat{\mathbf{e}}_y}. \quad (7)$$

We could have also solved the integral by splitting it into two parts,

$$\mathbf{F}_p = \int_{y=0}^{y=H} -(\rho gy) (-w dy \hat{\mathbf{e}}_x) + \int_{x=0}^{x=L} -(\rho gy) (-w dx \hat{\mathbf{e}}_y) = \frac{1}{2} \rho gw H^2 \hat{\mathbf{e}}_x + \int_{x=0}^{x=L} -\left[\rho g \left(\frac{H}{L}\right) x \right] (-w dx \hat{\mathbf{e}}_y), \quad (8)$$

$$\mathbf{F}_p = \frac{1}{2} \rho gw H^2 \hat{\mathbf{e}}_x + \frac{1}{2} \rho gw \left(\frac{H}{L}\right) L^2 \hat{\mathbf{e}}_y = \frac{1}{2} \rho gw H^2 \hat{\mathbf{e}}_x + \frac{1}{2} \rho gw HL \hat{\mathbf{e}}_y \quad \text{Same answer as before!} \quad (9)$$

Note that in the 2nd integral in Eq. (8), the y dependence on x needed to be made explicit in order to integrate properly with respect to x . An approach similar to what was used to derive Eq. (4) was utilized.

An alternate approach to solving this problem is to balance forces on the dashed volume of fluid shown below.

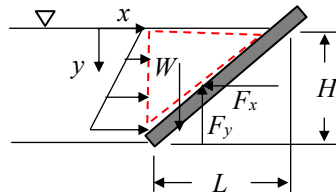

$$\sum F_x = 0 = \int_{y=0}^{y=H} (\rho g y)(w dy) - F_x \Rightarrow F_x = \frac{1}{2} \rho g w H^2 \quad \text{The same answer as before!} \quad (10)$$

$$\sum F_y = 0 = W - F_y = \rho \frac{1}{2} L H w g - F_y \Rightarrow F_y = \frac{1}{2} \rho g L H w \quad \text{The same answer as before!} \quad (11)$$

Note that from Newton's 3rd Law, the force the wall exerts on the fluid is equal and opposite to the force the fluid exerts on the wall.

Your professor purchased a watertight box to hold his camera while traveling to Ft. Myers Beach, FL during winter break. The box's dimensions are shown in the photograph. During the flight, he opened the box and then re-sealed it. Upon reaching his destination, he found that he had significant difficulty trying to open the box.

- Why was opening the box such a challenge?
- Estimate the force required to open the box if the force is applied at the front of the box. Note that the box is hinged at the back.

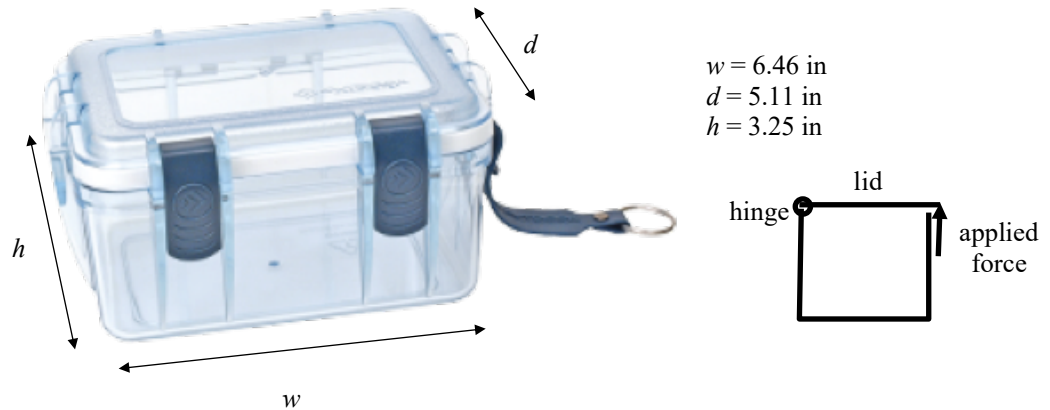

SOLUTION:

The box was difficult to open because the air in the interior of the box was at the cabin pressure of the aircraft (required to be pressurized to a maximum altitude of 8000 ft altitude¹) and the air outside the box was at the local atmospheric pressure (Ft. Myers Beach, FL which is at sea level). This pressure difference resulted in a net pressure force acting to hold the lid shut.

Sum moments about the lid's hinge,

$$\sum M_{\text{hinge}} = 0 = Fd - \int_{x=0}^{x=d} \underbrace{x}_{\text{moment arm}} \underbrace{(p_{\text{atm}} - p_{\text{box}})}_{\text{pressure difference}} \underbrace{wd}_{=dA} dx, \quad (1)$$

$$Fd = (p_{\text{atm}} - p_{\text{box}}) \frac{1}{2} wd^2, \quad (2)$$

$$F = (p_{\text{atm}} - p_{\text{box}}) \frac{1}{2} wd. \quad (3)$$

where

$$p_{\text{FMB}} = p_{\text{sea level}} = 14.7 \text{ psia (using a U.S. Standard Atmosphere)}$$

$$p_{\text{cabin}} = p_{8000 \text{ ft altitude}} = 10.9 \text{ psia (using a U.S. Standard Atmosphere)}$$

$$A_{\text{lid}} = wd = (6.46 \text{ in})(5.11 \text{ in}) = 33.0 \text{ in}^2$$

$$\Rightarrow F_{\text{lid}} = 62.5 \text{ lbf!}$$

¹ https://en.wikipedia.org/wiki/Cabin_pressurization

The gate shown below has a width of $w = 8$ ft and opens to let fresh water out when the ocean tide drops. The hinge is a height $h = 2$ ft above the freshwater level. At what ocean level H will the gate first open? You may neglect the weight of the gate.

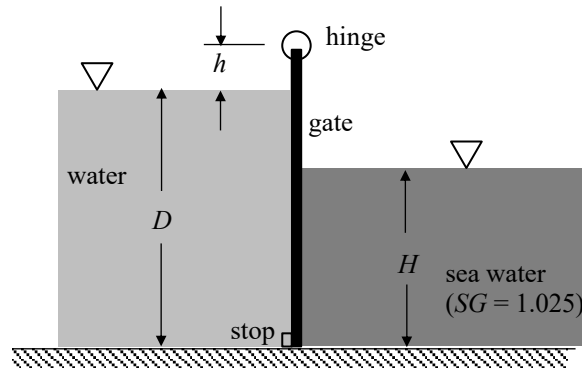

SOLUTION:

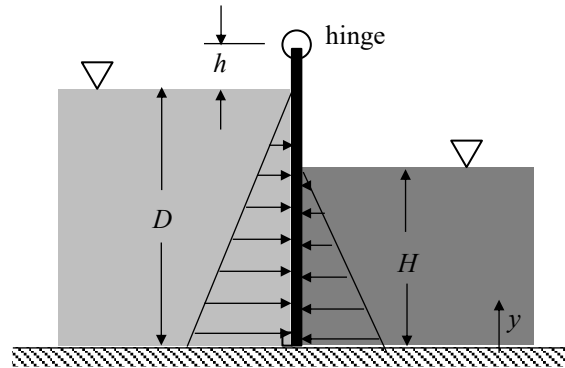

Balance moments about the hinge,

$$\sum M_{\text{hinge}} = 0 = \int_{y=0}^{y=D} \underbrace{(D+h-y)}_{\text{moment arm length}} \underbrace{\rho_{\text{fresh}} g (D-y)}_{\text{pressure}} \underbrace{(w dy)}_{\text{area}} - \int_{y=0}^{y=H} \underbrace{(D+h-y)}_{\text{moment arm length}} \underbrace{\rho_{\text{sea}} g (H-y)}_{\text{pressure}} \underbrace{(w dy)}_{\text{area}}, \quad (1)$$

$$\int_{y=0}^{y=D} (D+h-y) \rho_{\text{fresh}} g (D-y) (w dy) = \int_{y=0}^{y=H} (D+h-y) \rho_{\text{sea}} g (H-y) (w dy), \quad (2)$$

$$\rho_{\text{fresh}} \int_{y=0}^{y=D} (D+h-y)(D-y) dy = \rho_{\text{sea}} \int_{y=0}^{y=H} (D+h-y)(H-y) dy, \quad (3)$$

$$\rho_{\text{fresh}} \int_{y=0}^{y=D} (D^2 + Dh - 2Dy - hy + y^2) dy = \rho_{\text{sea}} \int_{y=0}^{y=H} (DH + Hh - Hy - Dy - hy + y^2) dy, \quad (4)$$

$$\rho_{\text{fresh}} \left[(D^2 + Dh)y - \frac{1}{2}(2D+h)y^2 + \frac{1}{3}y^3 \right]_{y=0}^{y=D} = \rho_{\text{sea}} \left[(DH + Hh)y - \frac{1}{2}(H+h+D)y^2 + \frac{1}{3}y^3 \right]_{y=0}^{y=H}, \quad (5)$$

$$\rho_{\text{fresh}} \left[(D^2 + Dh)D - \frac{1}{2}(2D+h)D^2 + \frac{1}{3}D^3 \right] = \rho_{\text{sea}} \left[(DH + Hh)H - \frac{1}{2}(H+h+D)H^2 + \frac{1}{3}H^3 \right], \quad (6)$$

$$D^3 + D^2h - D^3 - \frac{1}{2}D^2h + \frac{1}{3}D^3 = \frac{\rho_{\text{sea}}}{\rho_{\text{fresh}}} \left(DH^2 + H^2h - \frac{1}{2}H^3 - \frac{1}{2}H^2h - \frac{1}{2}DH^2 + \frac{1}{3}H^3 \right), \quad (7)$$

$$\frac{1}{2}D^2h + \frac{1}{3}D^3 = SG_{\text{sea}} \left(-\frac{1}{6}H^3 + \frac{1}{2}H^2h + \frac{1}{2}DH^2 \right), \quad (8)$$

$$\frac{1}{6}SG_{\text{sea}}H^3 - \frac{1}{2}SG_{\text{sea}}(D+h)H^2 + \frac{1}{2}D^2h + \frac{1}{3}D^3 = 0, \quad (9)$$

$$H^3 - 3(D+h)H^2 + \frac{(3h+2D)D^2}{SG_{\text{sea}}} = 0. \quad (10)$$

Using the given data,

$$SG_{\text{sea}} = 1.025$$

$$h = 2 \text{ ft}$$

$$D = 10 \text{ ft}$$

$$\text{Eq. (10)} \Rightarrow H^3 - (36 \text{ ft})H^2 + (2536.6 \text{ ft}^3) = 0 \quad (11)$$

Solving this equation numerically gives $H = 9.85 \text{ ft}$

For sea levels less than this critical value, the gate will open.

The $w = 4$ ft wide gate shown in the figure pivots about a hinge. The gate is held in place by a counterweight with a weight of $W = 2000$ lb_f, which is located a distance $h = 5$ ft below the base of the water and a distance $l = 3$ ft from the gate. Determine the depth of the water, H , for which the gate remains in the equilibrium position shown. You may assume the gate mass is small compared to the counterweight mass, and that the hinge friction is negligible.

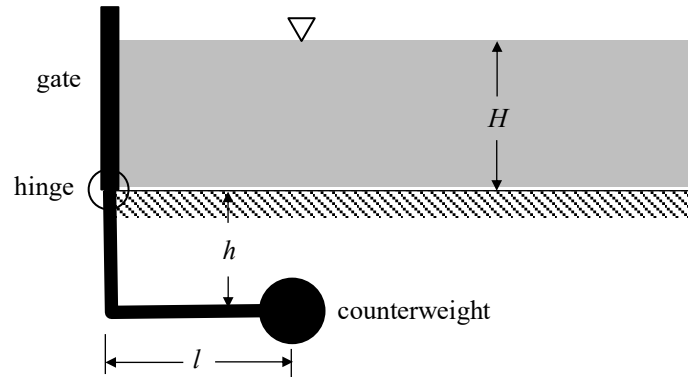

SOLUTION:

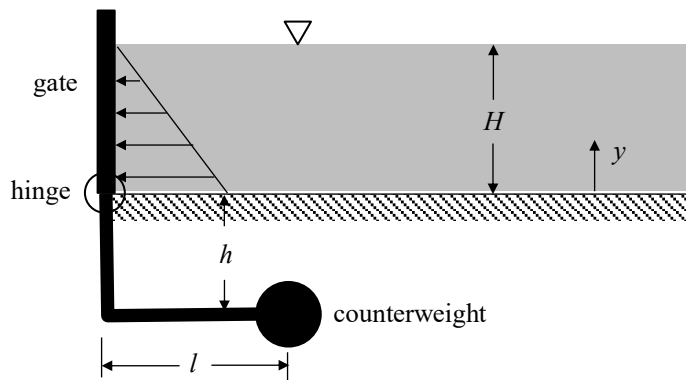

Balance moments about the hinge,

$$\sum M_{\text{hinge}} = 0 = \int_{y=0}^{y=H} \underbrace{y}_{\text{moment arm length}} \underbrace{\rho g(H-y)}_{\text{pressure}} \underbrace{(w dy)}_{\text{area}} - \underbrace{IW}_{\text{moment due to counterweight}}, \quad (1)$$

$$\rho g w \int_{y=0}^{y=H} y(H-y) dy = IW, \quad (2)$$

$$\rho g w \left(\frac{1}{2} H y^2 - \frac{1}{3} y^3 \right)_{y=0}^{y=H} = IW, \quad (3)$$

$$\frac{1}{6} H^3 = \frac{IW}{\rho g w}, \quad (4)$$

$$\boxed{H = \left(\frac{6IW}{\rho g w} \right)^{1/3}}. \quad (5)$$

Using the given data,

$$\rho g = 62.4 \text{ lb}_f/\text{ft}^3$$

$$W = 2000 \text{ lb}_f$$

$$l = 3 \text{ ft}$$

$$w = 4 \text{ ft}$$

$$\Rightarrow \boxed{H = 5.2 \text{ ft}}$$

The rigid, L-shaped gate shown in the figure can rotate about the hinge and rests against the rigid support at point A. What is the minimum horizontal force, F required to hold the gate closed if its width is $w = 3$ m and the lengths are $h = 4$ m and $l = 2$ m? The height of the free surface above the hinge is $H = 3$ m. You may neglect the weight of the gate and the friction in the hinge. Note that the back of the gate is exposed to the atmosphere.

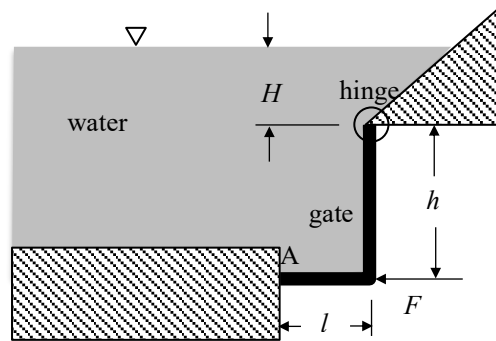

SOLUTION:

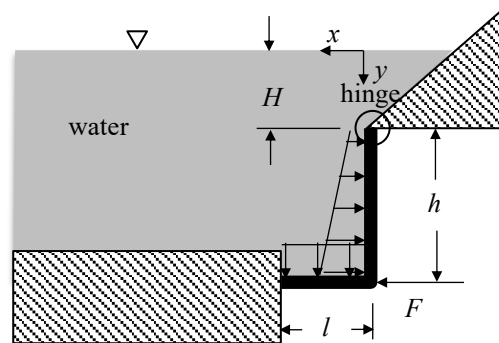

Balance moments about the hinge,

$$\sum M_{\text{hinge}} = 0 = \int_{y=H}^{y=H+h} \underbrace{(y-H)}_{\text{moment arm length}} \underbrace{\rho g y}_{\text{pressure}} \underbrace{(w dy)}_{\text{area}} + \int_{x=0}^{x=l} \underbrace{x}_{\text{moment arm length}} \underbrace{\rho g (H+h)}_{\text{pressure}} \underbrace{(w dx)}_{\text{area}} - \underbrace{hF}_{\text{moment due to applied force}}, \quad (1)$$

$$\rho g w \int_{y=H}^{y=H+h} (y-H)y dy + \rho g (H+h) w \int_{x=0}^{x=l} x dx - hF = 0, \quad (2)$$

$$hF = \rho g w \left(\frac{1}{3} y^3 - \frac{1}{2} H y^2 \right) \Big|_{y=H}^{y=H+h} + \frac{1}{2} \rho g (H+h) w l^2, \quad (3)$$

$$hF = \rho g w \left\{ \left[\frac{1}{3} (H+h)^3 - \frac{1}{2} H (H+h)^2 \right] - \left[\frac{1}{3} H^3 - \frac{1}{2} H H^2 \right] \right\} + \frac{1}{2} \rho g (H+h) w l^2, \quad (4)$$

$$F = \rho g w \left[\frac{1}{2} H h + \frac{1}{3} h^2 + \frac{1}{2} \left(\frac{H}{h} + 1 \right) l^2 \right]. \quad (5)$$

Using the given data,

$$\begin{aligned} \rho &= 1000 \text{ kg/m}^3 \\ g &= 9.81 \text{ m/s}^2 \\ w &= 3 \text{ m} \\ H &= 3 \text{ m} \\ h &= 4 \text{ m} \\ l &= 2 \text{ m} \end{aligned}$$

$$\Rightarrow \boxed{F = 437 \text{ kN}}$$

A rectangular block of concrete (SG=2.5) is used as a retaining wall or dam for a reservoir of water:

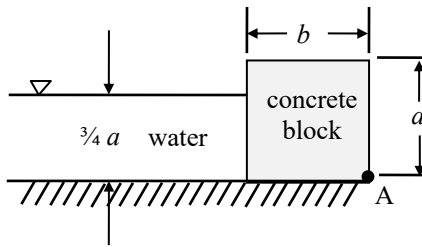

Figure (a)

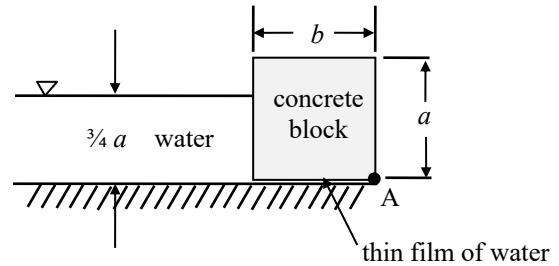

Figure (b)

The block has a height, a , a breadth, b , and unit depth into the page. The depth of the water is $3a/4$.

- Determine the critical ratio, b/a , below which the block will be overturned by the water (figure a). Assume the block does not slide on the base but can rotate about the point A. For figure (a), there is no fluid underneath the block.
- What is the critical ratio, b/a , if there is seepage and a thin film of water forms under the block (figure b)? Assume that a seal at point A prevents water from flowing out from underneath the block.

SOLUTION:

Draw a free body diagram of the block. Note that when the block is on the verge of tipping over, the vertical force the ground exerts on the block is zero.

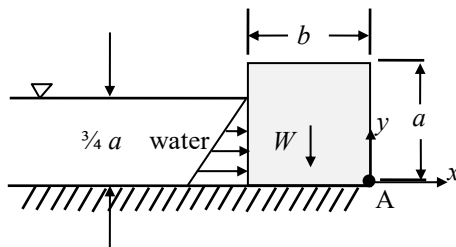

Sum moments about point A.

$$\sum M_A = 0 = \left(\frac{1}{2}b\right)W - \int_{y=0}^{y=\frac{3}{4}a} y p \underbrace{(dy \cdot 1)}_{=dA} \quad (1)$$

where

$$W = \rho_{\text{block}} (b \cdot a \cdot 1) g \quad (2)$$

$$p = \rho_{H_2O} g \left(\frac{3}{4}a - y\right) \quad (\text{note that this is a gage pressure}) \quad (3)$$

Substitute and simplify.

$$\left(\frac{1}{2}b\right)(\rho_{\text{block}} b a g) - \int_{y=0}^{y=\frac{3}{4}a} y \rho_{H_2O} g \left(\frac{3}{4}a - y\right) dy = 0 \quad (4)$$

$$\frac{1}{2} \rho_{\text{block}} b^2 a - \rho_{H20} \int_{y=0}^{y=\frac{3}{4}a} \left(\frac{3}{4} ay - y^2 \right) dy = 0 \quad (5)$$

$$\frac{1}{2} \rho_{\text{block}} b^2 a - \rho_{H20} \left(\frac{3}{8} ay^2 - \frac{1}{3} y^3 \right) \Big|_{y=0}^{y=\frac{3}{4}a} = 0 \quad (6)$$

$$\frac{1}{2} \rho_{\text{block}} b^2 a - \rho_{H20} \left(\frac{3}{8} \frac{9}{16} a^3 - \frac{1}{3} \frac{27}{64} a^3 \right) = 0 \quad (7)$$

$$\frac{1}{2} SG_{\text{block}} b^2 a - \frac{9}{128} a^3 = 0 \quad (8)$$

$$\left(\frac{b}{a} \right)^2 = \frac{9}{64} \frac{1}{SG_{\text{block}}} \quad (9)$$

$$\therefore \frac{b}{a} = \frac{3}{8} \frac{1}{\sqrt{SG_{\text{block}}}} \quad \text{when the block is just about to tip over} \quad (10)$$

Thus, the block will tip over for $SG_{\text{block}} = 2.5$ if $\boxed{b/a < 0.237}$.

Now draw the free body diagram for a block with a thin liquid layer underneath it.

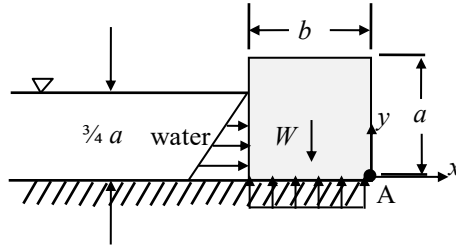

Sum moments about point A.

$$\sum M_A = 0 = \left(\frac{1}{2} b \right) W - \int_{y=0}^{y=\frac{3}{4}a} yp(dy \cdot 1) - \underbrace{\left(\frac{1}{2} b \right) \rho_{H20} g \frac{3}{4} a}_{=F} \underbrace{(b \cdot 1)}_{=A} \quad (11)$$

where the weight and pressure on the side are given in Eqs. (2) and (3). The last term in the previous equation is the (gage) pressure that the liquid layer on the bottom exerts on the block.

Substitute and simplify.

$$\frac{1}{2} SG_{\text{block}} b^2 a - \frac{9}{128} a^3 - \frac{3}{8} ab^2 = 0 \quad (12)$$

$$SG_{\text{block}} b^2 a - \frac{9}{64} a^3 - \frac{3}{4} ab^2 = 0 \quad (13)$$

$$SG_{\text{block}} \left(\frac{b}{a} \right)^2 - \frac{3}{4} \left(\frac{b}{a} \right)^2 = \frac{9}{64} \quad (14)$$

$$\therefore \frac{b}{a} = \frac{3}{8} \left(SG_{\text{block}} - \frac{3}{4} \right)^{-\frac{1}{2}} \quad \text{when the block is just about to tip over} \quad (15)$$

Thus, the block will tip over for $SG_{\text{block}} = 2.5$ if $\boxed{b/a < 0.283}$.

The 3 m wide (into the page) gate shown in the figure is hinged at point H . Calculate the force required at point A to hold the gate closed

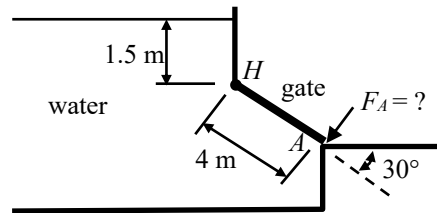

SOLUTION:

Draw a free body diagram of the gate, just as the gate is about to open.

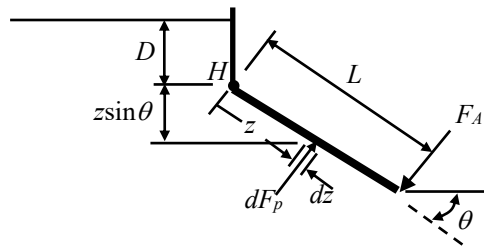

Sum moments about the hinge H and set them equal to zero since the gate isn't accelerating,

$$\sum M_H = 0 = \int_{z=0}^{z=L} \underbrace{z \rho g (D + z \sin \theta)}_{=p} \underbrace{(T dz)}_{=dA} - L F_A, \quad (1)$$

where T is the thickness of the gate into the page. The first z in the integral is the moment arm out to the differential hydrostatic pressure force dF_p acting on area $dA = T dz$. Note that the pressure is a function of the depth from the free surface, $D + z \sin \theta$.

Simplify Eq. (1) and solve for F_A ,

$$L F_A = \rho g T \int_{z=0}^{z=L} (D z dz + \sin \theta z^2 dz), \quad (2)$$

$$L F_A = \rho g T \left(\frac{1}{2} D L^2 + \frac{1}{3} L^3 \sin \theta \right), \quad (3)$$

$$\boxed{F_A = \rho g T L \left(\frac{1}{2} D + \frac{1}{3} L \sin \theta \right)}. \quad (4)$$

Using the given data,

$$\rho = 1000 \text{ kg/m}^3,$$

$$g = 9.81 \text{ m/s}^2,$$

$$T = 3 \text{ m},$$

$$L = 4 \text{ m},$$

$$D = 1.5 \text{ m},$$

$$\theta = 30^\circ,$$

$$\Rightarrow \boxed{F_A = 167 \text{ kN}}$$

A plane gate of uniform thickness t and width into the page w holds back a depth of water as shown. Find the minimum weight of the gate needed to keep the gate closed.

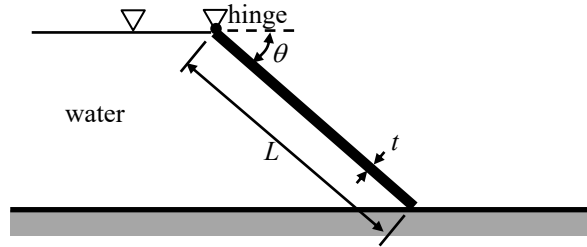

SOLUTION:

Draw a free body diagram of the gate.

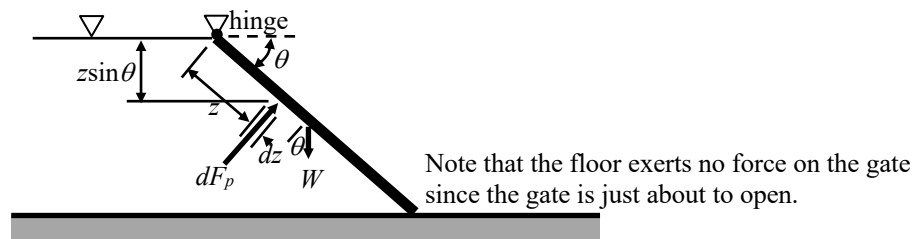

Sum moments about the gate's hinge, noting that the gate is in equilibrium and just about to open,

$$\sum M_{\text{hinge}} = 0 = -\left(\frac{L}{2}\right)(W \cos \theta) + \int_{z=0}^{z=L} \underbrace{z(\rho g z \sin \theta)}_{=p} \underbrace{(w dz)}_{=dF_p}, \quad (1)$$

$$\left(\frac{L}{2}\right)(W \cos \theta) = \rho g w \sin \theta \int_{z=0}^{z=L} z^2 dz, \quad (2)$$

$$\left(\frac{L}{2}\right)(W \cos \theta) = \frac{1}{3} \rho g w L^3 \sin \theta, \quad (3)$$

$$\boxed{W = \frac{2}{3} \rho g w L^2 \tan \theta}. \quad (4)$$

The tank shown below is partially filled with a liquid of density ρ and is open to the atmosphere. A triangular gate is hinged at the bottom and held closed by a force applied at the top. Determine the force F in terms of the liquid density ρ , the acceleration due to gravity g , the liquid depth D , the gate height H , and the gate width W .

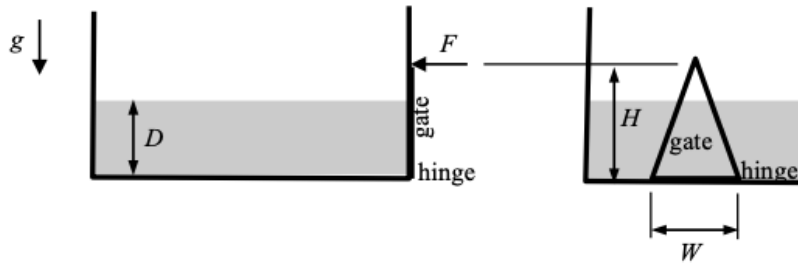

SOLUTION:

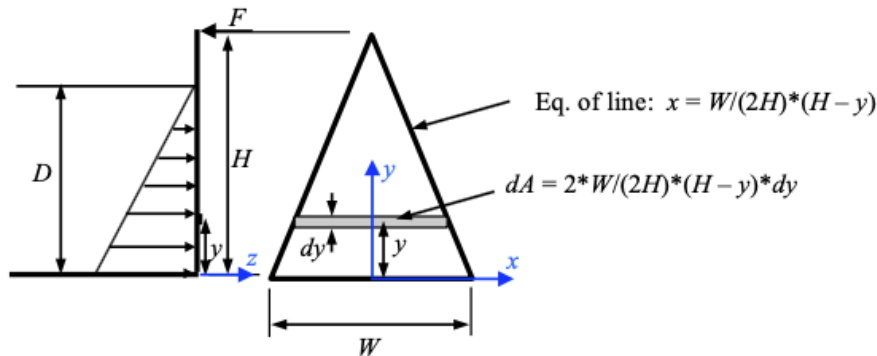

Balance moments on the gate. Since the pressure varies over the surface of the gate and because the gate width changes with depth, we'll need to integrate the pressure force over the gate surface. To do this, divide the gate into small areas over which the pressure remains constant.

$$\sum \mathbf{M}_{hinge} = \mathbf{0} = (H\hat{j} \times -F\hat{k}) + \int_A \underbrace{y\hat{j}}_{\text{moment arm}} \times \underbrace{d\mathbf{F}_p}_{\text{pressure force}}, \quad (1)$$

where,

$$d\mathbf{F}_p = -pdA, \quad (2)$$

$$dA = 2\left(\frac{W}{2H}\right)(H-y)dy(-\hat{k}), \quad (3)$$

$$p_{gate} = \rho g(D-y). \quad (4)$$

Substitute and solve for F ,

$$\mathbf{0} = HF\hat{i} + \int_{y=0}^{y=D} y\rho g(D-y)2\left(\frac{W}{2H}\right)(H-y)dy(-\hat{i}), \quad (5)$$

$$HF = \rho g\left(\frac{W}{H}\right) \int_0^D y(D-y)(H-y)dy = \rho g\left(\frac{W}{H}\right) \int_0^D [DHy - (D+H)y^2 + y^3]dy, \quad (6)$$

$$F = \rho g\left(\frac{W}{H^2}\right) \left[\frac{1}{2}D^3H - \frac{1}{3}(D+H)D^3 + \frac{1}{4}D^4 \right], \quad (7)$$

$$F = \rho g\left(\frac{W}{H^2}\right) \left[\frac{1}{2}D^3H - \frac{1}{3}D^4 - \frac{1}{3}HD^3 + \frac{1}{4}D^4 \right], \quad (8)$$

$$F = \frac{1}{6}\rho g\left(\frac{WD^3}{H^2}\right) \left(H - \frac{1}{2}D \right). \quad (9)$$

A cylindrical tank is filled with water. In order to control the flow rate from the tank, a pressure can be applied to the water surface by a compressor. For an applied absolute pressure of 3 bar, calculate the hydrostatic force exerted by the water on the end surface of the tank.

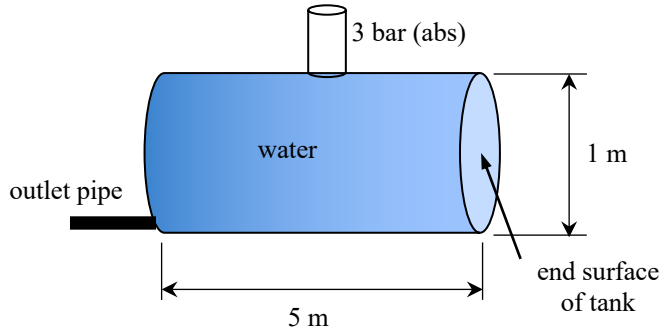

SOLUTION:

Draw the pressure distribution acting on the tank end surface due to the water in the tank.

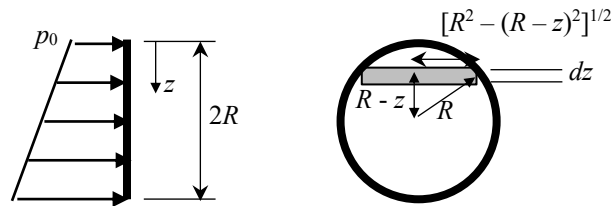

The hydrostatic pressure force on the tank surface due to the water is,

$$F = \int_{z=0}^{z=2R} p dA = \int_{z=0}^{z=2R} \underbrace{(p_0 + \rho g z)}_{=p} \underbrace{2\sqrt{R^2 - (R-z)^2}}_{=dA} dz, \tag{1}$$

$$F = 2 \int_{z=0}^{z=2R} (p_0 + \rho g z) \sqrt{2Rz - z^2} dz = 2 \left[p_0 \int_{z=0}^{z=2R} \sqrt{2Rz - z^2} dz + \rho g \int_{z=0}^{z=2R} z \sqrt{2Rz - z^2} dz \right], \tag{2}$$

$$F = 2 \left[p_0 \frac{\pi R^2}{2} + \rho g \frac{\pi R^3}{2} \right], \tag{3}$$

$$F = \pi R^2 (p_0 + \rho g R). \tag{4}$$

Using the following parameters:

$$R = 0.5 \text{ m}$$

$$p_0 = 3 \text{ bar (abs)} = 300 \text{ kPa (abs)}$$

$$\rho = 1000 \text{ kg/m}^3$$

$$g = 9.81 \text{ m/s}^2$$

$$\Rightarrow F = 23.6 \text{ MN}.$$

Note an alternate approach to solving the problem is to break the applied pressure into a constant part at pressure p_0 and the linearly increasing part, as shown in the figures below.

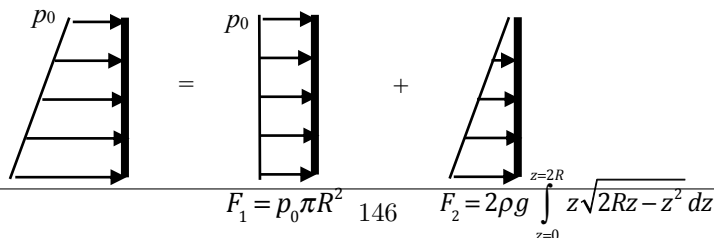

A semi-circular plane gate is hinged along B and held by horizontal force F applied at point A. The liquid in the reservoir is water. Calculate the minimum force required to hold the gate closed. Hint: An integral table or symbolic algebra software will be helpful in solving the integrals that appear in the derivation.

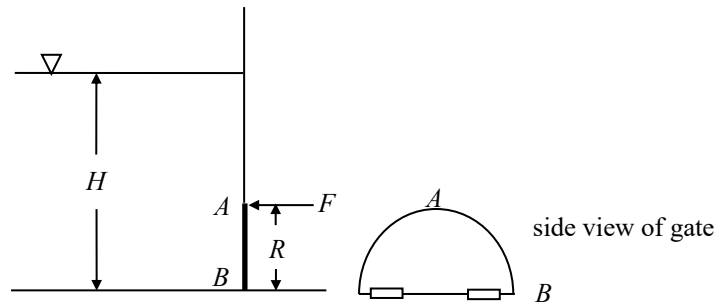

SOLUTION:

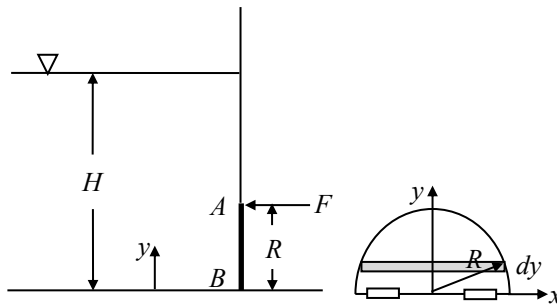

Sum moments about point B.

$$\sum M_B = 0 = RF - \int_{y=0}^{y=R} y p dA \quad (1)$$

$$RF = \int_{y=0}^{y=R} y \underbrace{\rho g (H - y)}_{=p_{\text{gage}}} \underbrace{2\sqrt{R^2 - y^2}}_{=dA} dy \quad (2)$$

$$F = \frac{2\rho g}{R} \int_{y=0}^{y=R} y(H - y)\sqrt{R^2 - y^2} dy \quad (3)$$

$$F = \frac{2\rho g}{R} \left[H \int_{y=0}^{y=R} y\sqrt{R^2 - y^2} dy - \int_{y=0}^{y=R} y^2\sqrt{R^2 - y^2} dy \right] \quad (4)$$

Evaluate the integrals using an integral table or symbolic algebra software (e.g., Mathematica).

$$F = \frac{2\rho g}{R} \left[-\frac{1}{3} H (R^2 - y^2)^{3/2} \Big|_{y=0}^{y=R} - \frac{1}{8} \left(y\sqrt{R^2 - y^2} (2y^2 - R^2) + R^4 \tan^{-1} \left(\frac{y}{\sqrt{R^2 - y^2}} \right) \right) \Big|_{y=0}^{y=R} \right] \quad (5)$$

$$F = \frac{2\rho g}{R} \left(\frac{1}{3} HR^3 - \frac{1}{8} R^4 \frac{\pi}{2} \right) \quad (6)$$

$$\boxed{\therefore F = 2\rho g R^2 \left(\frac{1}{3} H - \frac{\pi}{16} R \right)} \quad (7)$$

2.3.2. Curved Surfaces

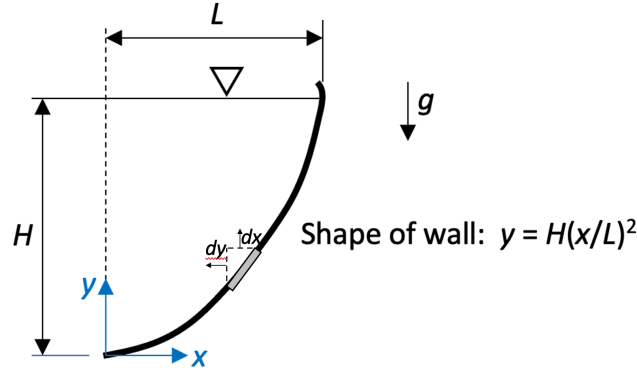

FIGURE 2.14. The parabolically-shaped wall used in the example.

The resultant pressure force and center of pressure location for curved surfaces may be found in the same way as for flat surfaces. The only significant difference is that the unit normal vectors for the differentially-small area elements may change with position. For example, let's determine the net pressure force and center of pressure on the parabolically-shaped wall shown in Figure 2.14. Assume the wall is planar and has a depth W into the page.

$$\mathbf{F}_p = \int_A p(-d\mathbf{A}) = \int_A \underbrace{\rho g(H-y)}_{=p_{\text{gage}}} \underbrace{\left[-(W dx \hat{\mathbf{j}} - W dy \hat{\mathbf{i}})\right]}_{=-d\mathbf{A}} = -\rho g W \int_A (H-y)(dx \hat{\mathbf{j}} - dy \hat{\mathbf{i}}). \quad (2.45)$$

Before setting the limits on the integral, note that y is a function of x on the wall surface, which also means that a small displacement in the y direction is related to a small displacement in the x direction,

$$y = H \left(\frac{x}{L}\right)^2 \implies dy = \frac{2H}{L^2} x dx. \quad (2.46)$$

We can use this information to express the integral in terms of a single variable (we'll use x , but we could use y too). Substituting Eq. (2.46) into Eq. (2.45) gives,

$$\mathbf{F}_p = -\rho g W \int_{x=0}^{x=L} \left[H - H \left(\frac{x}{L}\right)^2 \right] \left(dx \hat{\mathbf{j}} - \frac{2H}{L^2} x dx \hat{\mathbf{i}} \right), \quad (2.47)$$

$$= -\rho g W H \left[\hat{\mathbf{j}} \int_{x=0}^{x=L} \left(1 - \frac{x^2}{L^2} \right) dx - \hat{\mathbf{i}} \frac{2H}{L^2} \int_{x=0}^{x=L} \left(x - \frac{x^3}{L^2} \right) dx \right], \quad (2.48)$$

$$= -\rho g W H \left[\hat{\mathbf{j}} \left(L - \frac{1}{3} L^3 L^2 \right) - \hat{\mathbf{i}} \frac{2H}{L^2} \left(\frac{1}{2} L^2 - \frac{1}{4} L^4 L^2 \right) \right], \quad (2.49)$$

$$= \rho g W H \left(\frac{1}{2} H \hat{\mathbf{i}} - \frac{2}{3} L \hat{\mathbf{j}} \right), \quad (2.50)$$

$$\mathbf{F}_p = \frac{1}{2} \rho g W H^2 \hat{\mathbf{i}} - \frac{2}{3} \rho g W H L \hat{\mathbf{j}}. \quad (2.51)$$

This result is the pressure force the fluid exerts on the wall.

The center of pressure is found by balancing moments, identical to what was used for planar surfaces. Balance moments about the origin,

$$\mathbf{x}_{CP} \times \mathbf{F}_p = \int_A (x\hat{i} + y\hat{j}) \times [\rho g(H - y)] [-Wdx\hat{j} - Wdy\hat{i}] = -\rho gW \int_A (H - y)(xdx + ydy)\hat{k}, \quad (2.52)$$

$$(x_{CP}\hat{i} + y_{CP}\hat{j}) \times \left(\frac{1}{2}\rho gWH^2\hat{i} - \frac{2}{3}\rho gWHL\hat{j} \right) \quad (2.53)$$

$$= -\rho gW\hat{k} \int_{x=0}^{x=L} \left[H \left(1 - \frac{x^2}{L^2} \right) xdx + H \left(1 - \frac{x^2}{L^2} \right) H \left(\frac{x^2}{L^2} \right) \frac{2H}{L^2} xdx \right], \quad (2.54)$$

$$-\rho gWH \left(x_{CP}\frac{2}{3}L + y_{CP}\frac{1}{2}H \right) \hat{k} = -\rho gWH\hat{k} \int_{x=0}^{x=L} \left[\left(x - \frac{x^3}{L^2} \right) + \frac{2H^2}{L^4} \left(x^3 - \frac{x^5}{L^2} \right) \right] dx, \quad (2.55)$$

$$x_{CP}\frac{2}{3}L + y_{CP}\frac{1}{2}H = \frac{1}{2}L^2 - \frac{1}{4}\frac{L^4}{L^2} + \frac{2H^2}{L^4} \left(\frac{1}{4}L^4 - \frac{1}{6}\frac{L^6}{L^2} \right) = \frac{1}{4}L^2 + \frac{1}{6}H^2, \quad (2.56)$$

$$\therefore y_{CP} = \left(-\frac{4}{3}\frac{L}{H} \right) x_{CP} + \left(\frac{1}{2}\frac{L^2}{H} + \frac{1}{3}H \right). \quad (2.57)$$

The previous equation, which is the equation of a line, is known as the line of action. It is the line along which the resultant force acts. This line of action is shown graphically in Figure 2.15. Now find the intersection of

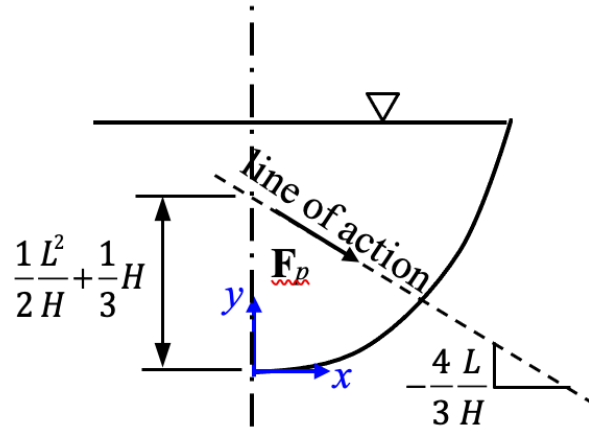

FIGURE 2.15. A sketch showing the line of action for the parabolic wall example.

the line of action and the wall by substituting Eq. (2.46) into Eq. (2.57),

$$H \left(\frac{x_{CP}}{L} \right)^2 = \left(-\frac{4}{3}\frac{L}{H} \right) x_{CP} + \left(\frac{1}{2}\frac{L^2}{H} + \frac{1}{3}H \right), \quad (2.58)$$

$$\left(\frac{x_{CP}}{L} \right)^2 + \frac{4}{3} \left(\frac{L}{H} \right)^2 \left(\frac{x_{CP}}{L} \right) - \left[\frac{1}{2} \left(\frac{L}{H} \right)^2 + \frac{1}{3} \right] = 0. \quad (2.59)$$

Solving this (unfortunately messy) equation gives,

$$\frac{x_{CP}}{L} = -\frac{2}{3} \left(\frac{L}{H} \right)^2 + \sqrt{\frac{4}{9} \left(\frac{L}{H} \right)^4 + \frac{1}{2} \left(\frac{L}{H} \right)^2 + \frac{1}{3}}. \quad (2.60)$$

Note that only the positive root of the previous equation makes physical sense. Now that we have x_{CP} , the value for y_{CP} can then be found by substituting this value into Eq. (2.46).

Notes:

- (1) The horizontal component of the resultant pressure force in Eq. (2.51) is equal to the resultant force acting on the vertical projected area HW , i.e., $F_{P,x} = \frac{1}{2}\rho g H^2 W$.

An alternate method for determining the resultant force and center of pressure is to balance forces on a region of fluid bordered by the wall. For example, balance forces on the region of fluid identified by the dotted line in Figure 2.16.

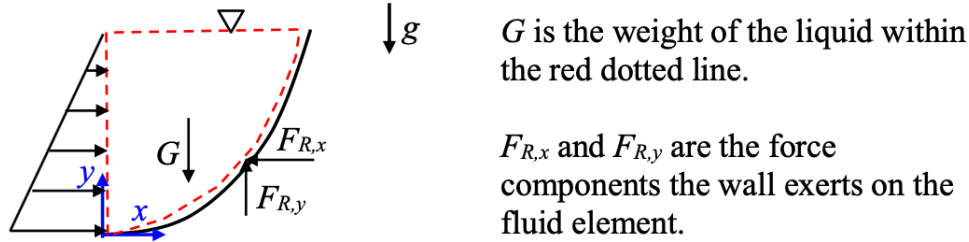

FIGURE 2.16. Free body diagram for the region of fluid enclosed by the red dashed line.

$$\sum F_x = 0 = \frac{1}{2}\rho g H^2 W - F_{R,x} \implies F_{R,x} = \frac{1}{2}\rho g H^2 W, \quad (2.61)$$

$$\sum F_y = 0 = -G + F_{R,y} \implies F_{R,y} = G, \quad (2.62)$$

where,

$$G = \int_{x=0}^{x=L} \underbrace{\rho g (H - y) dx W}_{=dV} = \int_{x=0}^{x=L} \rho g \left[H - H \left(\frac{x}{L} \right)^2 \right] dx W, \quad (2.63)$$

$$= \rho g H W \int_{x=0}^{x=L} \left(1 - \frac{x^2}{L^2} \right) dx = \rho g H W \left(L - \frac{1}{3} \frac{L^3}{L^2} \right), \quad (2.64)$$

$$G = \frac{2}{3} \rho g H W L, \quad (2.65)$$

so that,

$$F_{R,y} = \frac{2}{3} \rho g H W L. \quad (2.66)$$

These magnitudes for $F_{R,x}$ and $F_{R,y}$ are exactly the same as what was found in Eq. (2.51). Note that here $F_{R,x}$ and $F_{R,y}$ are the force components the wall exerts on the fluid so, from Newton's Third Law, the fluid exerts equal and opposite force components on the wall.

The center of pressure about the z axis is found by balancing moments about the origin, the same as what was done for planar walls,

$$\mathbf{x}_{CP} \times \mathbf{F}_p = \left(\underbrace{\frac{1}{3} H \hat{\mathbf{j}}}_{\text{CP on left side}} \times \underbrace{\frac{1}{2} \rho g H^2 W \hat{\mathbf{i}}}_{\text{resultant force on left side}} \right) + \left[\underbrace{(x_{CM} \hat{\mathbf{i}} + y_{CM} \hat{\mathbf{j}})}_{\text{center of mass}} \times \underbrace{-\frac{2}{3} \rho g H W L \hat{\mathbf{j}}}_{\text{weight of fluid region}} \right]. \quad (2.67)$$

Since the weight has no x component, we need not worry about calculating y_{CM} . However, we do need the x component of the center of mass, which we can find via integration (refer to the figure),

$$x_{CM}G = \int_{x=0}^{x=L} x \rho g \underbrace{(H-y)W dx}_{=dV}, \quad (2.68)$$

$$= \int_{x=0}^{x=L} x \rho g \left[H - H \left(\frac{x}{L} \right)^2 \right] W dx, \quad (2.69)$$

$$= \rho g H W \int_{x=0}^{x=L} \left(x - \frac{x^3}{L^2} \right) dx, \quad (2.70)$$

$$x_{CM} \frac{2}{3} \rho g H W L = \rho g H W \left(\frac{1}{2} L^2 - \frac{1}{4} \frac{L^4}{L^2} \right), \quad (2.71)$$

$$= \frac{1}{4} \rho g H W L^2, \quad (2.72)$$

$$x_{CM} = \frac{3}{8} L. \quad (2.73)$$

Substituting this value back into the right-hand side of Eq. (2.67) and making use of the resultant pressure force on the left-hand side,

$$(x_{CP} \hat{i} + y_{CP} \hat{j}) \times \left(\frac{1}{2} \rho g H^2 W \hat{i} - \frac{2}{3} \rho g H W L \hat{j} \right) \quad (2.74)$$

$$= \left(\frac{1}{3} H \hat{j} \times \frac{1}{2} \rho g H^2 W \hat{i} \right) + \left(\frac{3}{8} L \hat{i} \times -\frac{2}{3} \rho g H W L \hat{j} \right), \quad (2.75)$$

$$- x_{CP} \frac{2}{3} \rho g H W L \hat{k} - y_{CP} \frac{1}{2} \rho g H^2 W \hat{k} = -\frac{1}{6} \rho g H^3 W \hat{k} - \frac{1}{4} \rho g H W L^2 \hat{k}, \quad (2.76)$$

$$y_{CP} = \left(-\frac{4}{3} \frac{L}{H} \right) x_{CP} + \left(\frac{1}{3} H + \frac{1}{2} \frac{L^2}{H} \right), \quad (2.77)$$

which is the same line of action found previously.

Notes:

- (1) Either approach to finding the resultant force and center of pressure (integration or balancing forces on a wisely-chosen region of fluid) is fine. One method may be easier than the other, depending on the geometry of the problem.
- (2) Yet another method to finding the resultant pressure force and center of pressure relies on calculating the center of area of the wall surface and calculating moments of inertia. This approach isn't described in these notes since it's a more "formulaic" approach and is less connected to the actual physics of the problem. Moreover, this moment-of-inertia approach often requires access to moment of inertia tables, which may be inconvenient. A number of texts that discuss fluid statics present this "moments-of-inertia" approach, but it's not this author's preferred method.

Calculate the net horizontal pressure force acting on the half cylinder shown below. The half cylinder has radius R unit depth into the page, and the gage pressure acting on it is p_0 .

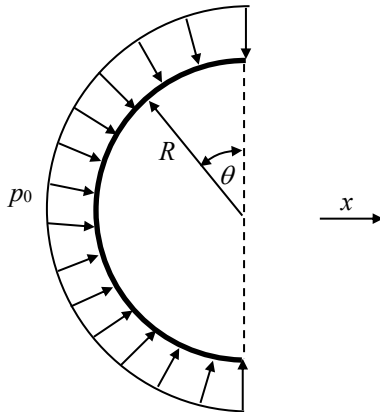

SOLUTION:

We can determine the net horizontal pressure force in two ways. The first method directly integrates the horizontal pressure force components over the entire surface and the second method uses the surface's projected area.

Method 1: Integrate the horizontal pressure force components over the entire surface area.

$$dF_{p,x} = p_0 \underbrace{Rd\theta}_{=dA} \sin\theta = dF_p \quad (1)$$

$$F_{p,x} = \int_{\theta=0}^{\theta=\pi} dF_{p,x} = \int_{\theta=0}^{\theta=\pi} p_0 R d\theta \sin\theta = p_0 R \int_{\theta=0}^{\theta=\pi} \sin\theta d\theta = -p_0 R \cos\theta \Big|_0^\pi = -p_0 R (-1 - 1) \quad (2)$$

$$\boxed{\therefore F_{p,x} = p_0 (2R)} \quad (3)$$

Method 2: Multiply the pressure with the surface's area projected in the x -direction.

The small amount of horizontal pressure force $dF_{p,x}$ due to the pressure p_0 acting on a small area dA inclined at an angle θ as shown in the figure to the right is,

$$dF_{p,x} = p_0 \underbrace{dA \sin\theta}_{=dA'} \quad (4)$$

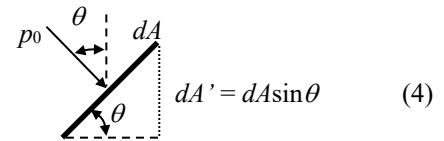

By grouping terms, we see that horizontal pressure force is equivalent to multiplying the pressure by the area projected in the horizontal direction, dA' , *i.e.*, the area of the surface viewed from the x -direction.

$$dF_{p,x} = p_0 \underbrace{dA \sin\theta}_{=dA'} \quad (5)$$

Thus, the horizontal pressure force acting on the half-cylinder is simply the pressure multiplied by the cylinder's horizontal projected area, $2R$,

$$\boxed{\therefore F_{p,x} = p_0 (2R)} \quad (\text{This is the same result as before!}) \quad (6)$$

The figure shows a Tainter gate used to control water flow from a dam. The gate radius is $R = 20$ m, the gate width is $w = 35$ m, and the water depth is $H = 10$ m. Determine the force components, magnitude, and line of action of the force that the water exerts on the gate.

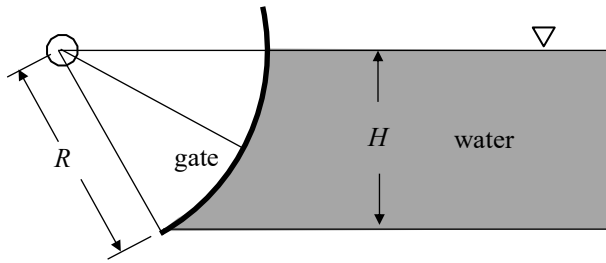

SOLUTION:

First determine the force components acting on the gate,

$$\mathbf{F} = \int_{y=0}^{y=H} p(-d\mathbf{A}) = \int_{y=0}^{y=H} (\rho g y)[-(Rd\theta w \hat{\mathbf{e}}_r)], \quad (1)$$

$$\mathbf{F} = \int_{\theta=0}^{\theta=\theta_M} (\rho g R \sin \theta)(-Rd\theta w \hat{\mathbf{e}}_r), \quad (2)$$

where,

$$\sin \theta_M = \frac{H}{R} \Rightarrow \theta_M = \sin^{-1}\left(\frac{H}{R}\right), \quad (3)$$

$$\hat{\mathbf{e}}_r = \cos \theta \hat{\mathbf{i}} + \sin \theta \hat{\mathbf{j}}. \quad (4)$$

Substitute and simplify,

$$\mathbf{F} = \int_0^{\theta_M} (\rho g R \sin \theta)[-Rd\theta w (\cos \theta \hat{\mathbf{i}} + \sin \theta \hat{\mathbf{j}})], \quad (5)$$

$$\mathbf{F} = -\rho g R^2 w \int_0^{\theta_M} (\sin \theta \cos \theta d\theta \hat{\mathbf{i}} + \sin^2 \theta d\theta \hat{\mathbf{j}}), \quad (6)$$

$$\mathbf{F} = -\rho g R^2 w \left\{ \left(\frac{1}{2} \sin^2 \theta_M \right) \hat{\mathbf{i}} + \left[\frac{1}{2} \theta_M - \frac{1}{4} \sin(2\theta_M) \right] \hat{\mathbf{j}} \right\}, \quad (7)$$

$$F_x = -\frac{1}{2} \rho g R^2 w \sin^2 \theta_M, \quad (8)$$

$$F_y = -\frac{1}{2} \rho g R^2 w \left[\theta_M - \frac{1}{2} \sin(2\theta_M) \right], \quad (9)$$

$$F_x = -\frac{1}{2} \rho g R^2 w \left(\frac{H}{R} \right)^2 \Rightarrow F_x = -\frac{1}{2} \rho g H^2 w. \quad (10)$$

$$F_y = -\frac{1}{2} \rho g R^2 w \left[\theta_M - \frac{1}{2} \sin(2\theta_M) \right] \quad (\text{where } \theta_M \text{ is given in Eq. (3)}). \quad (11)$$

Using the given data,

$$\rho = 1000 \text{ kg/m}^3,$$

$$g = 9.81 \text{ m/s}^2,$$

$$w = 35 \text{ m},$$

$$H = 10 \text{ m},$$

$$R = 20 \text{ m},$$

$$\Rightarrow \boxed{F_x = -17.2 \text{ MN and } F_y = -6.22 \text{ MN}}$$

and the force magnitude is $|\mathbf{F}| = 18.3 \text{ MN}$. The angle from the horizontal is,

$$\tan \theta_{CP} = \frac{F_y}{F_x}, \quad (\text{refer to the figure to the right}) \quad (12)$$

$$\boxed{\theta_{CP} = 19.9^\circ}$$

Note that the resultant force will pass through the center of the circle (the hinge) since the pressure force acts normal to the surface.

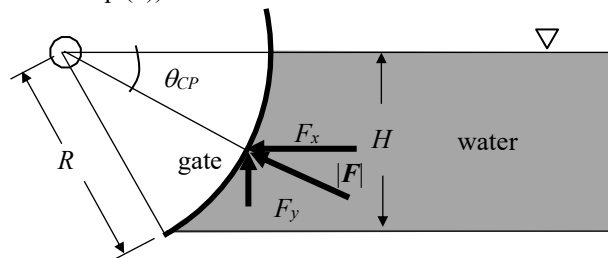

A spring-loaded hinge is designed to hold closed the sinusoidally-shaped gate shown in the figure (assume unit depth into the page). The wavelength of the gate shape is λ and its amplitude is a . The water depth is $H < a$. liquid in the figure is water. Determine the horizontal and vertical components of the force acting in the hinge due to the gate, as well as the moment the hinge must supply to keep the gate in the configuration shown. You may neglect the weight of the gate in your calculations.

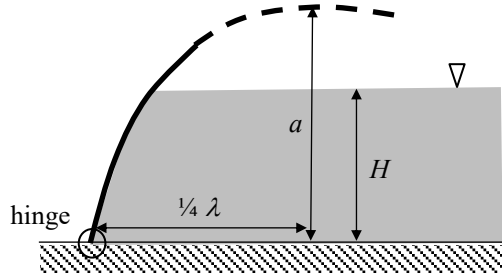

SOLUTION:

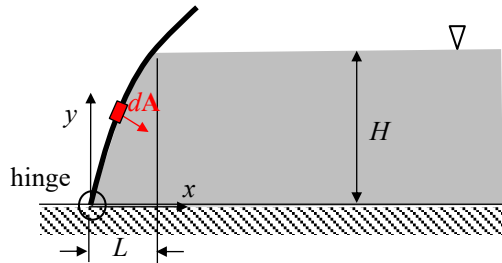

First determine the water force acting on the gate.

$$\mathbf{F} = - \int_A p d\mathbf{A}, \quad (1)$$

where

$$p = \rho g(H - y), \quad (2)$$

$$d\mathbf{A} = dy(1)\hat{\mathbf{i}} - dx(1)\hat{\mathbf{j}}. \quad (3)$$

Substituting Eqs. (2) and (3) into Eq. (1) gives,

$$\mathbf{F} = - \int_A \rho g(H - y) [dy(1)\hat{\mathbf{i}} - dx(1)\hat{\mathbf{j}}], \quad (4)$$

Split the integral into two parts: one concerning the vertical force component and one concerning the horizontal force component. The integral limits for the horizontal force component are simply $y = 0$ to $y = H$. The integral limits for the vertical force component are $x = 0$ to $x = L$, where L may be found by noting that the gate is sinusoidal in shape,

$$y = a \sin\left(2\pi \frac{x}{\lambda}\right) \Rightarrow L = \frac{\lambda}{2\pi} \sin^{-1}\left(\frac{H}{a}\right). \quad (5)$$

Thus, Eq. (4) may be written as,

$$\mathbf{F} = -\hat{\mathbf{i}}\rho g \int_{y=0}^{y=H} (H - y) dy + \hat{\mathbf{j}}\rho g \int_{x=0}^{x=L} (H - y) dx, \quad (6)$$

$$\mathbf{F} = -\hat{\mathbf{i}}\rho g \int_{y=0}^{y=H} (H - y) dy + \hat{\mathbf{j}}\rho g \int_{x=0}^{x=L} \left[H - a \sin\left(2\pi \frac{x}{\lambda}\right) \right] dx, \quad (7)$$

where Eq. (5) has been used to substitute in for y . Evaluating the integrals in Eq. (7) gives,

$$\mathbf{F} = -\hat{\mathbf{i}}\rho g \left(Hy - \frac{1}{2}y^2 \right)_{y=0}^{y=H} + \hat{\mathbf{j}}\rho g \left[Hx + \frac{a\lambda}{2\pi} \cos\left(2\pi \frac{x}{\lambda} \right) \right]_{x=0}^{x=L}, \quad (8)$$

$$\mathbf{F} = -\hat{\mathbf{i}}\frac{1}{2}\rho g H^2 + \hat{\mathbf{j}}\rho g \left\{ HL - \frac{a\lambda}{2\pi} \left[1 - \cos\left(2\pi \frac{L}{\lambda} \right) \right] \right\}, \quad (9)$$

where L is given in Eq. (5). Note that these are the forces acting on the gate due to the water. The forces acting on the hinge would have the same magnitude, but opposite sign,

$$\mathbf{F}_{\text{hinge}} = \hat{\mathbf{i}}\frac{1}{2}\rho g H^2 - \hat{\mathbf{j}}\rho g \left\{ HL - \frac{a\lambda}{2\pi} \left[1 - \cos\left(2\pi \frac{L}{\lambda} \right) \right] \right\}. \quad (10)$$

The horizontal pressure force is the same pressure force that's exerted on the horizontal, projected area of the gate,

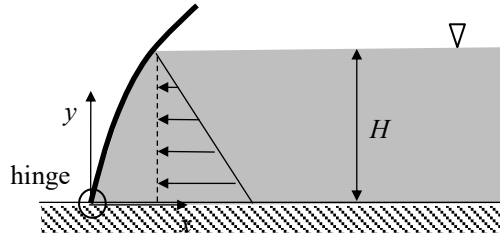

$$F_x = - \int_{y=0}^{y=H} \rho g (H - y) dy (1) = -\frac{1}{2}\rho g H^2. \quad (11)$$

The vertical pressure force could have also been found by balancing forces on the fluid contained within the span from $x = 0$ to $x = L$,

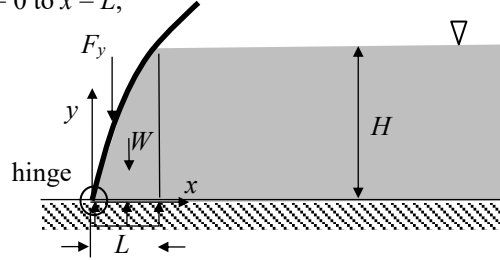

$$\sum F_y = 0 = -F_y - W + \rho g HL (1), \quad (12)$$

where the $\rho g HL$ term is the (uniform) pressure force acting on the bottom of the section of fluid under consideration. The weight of the fluid in the section is given by,

$$W = \rho g \int_{x=0}^{x=L} y dx (1) = \rho g \int_{x=0}^{x=L} a \sin\left(\frac{2\pi}{\lambda} x \right) dx (1) = \rho g \frac{a\lambda}{2\pi} \left[1 - \cos\left(\frac{2\pi}{\lambda} L \right) \right]. \quad (13)$$

Combining Eqs. (12) and (13) and solving for F_y gives,

$$F_y = \rho g HL - \rho g \frac{a\lambda}{2\pi} \left[1 - \cos\left(\frac{2\pi}{\lambda} L \right) \right] = \rho g \left\{ HL - \frac{a\lambda}{2\pi} \left[1 - \cos\left(\frac{2\pi}{\lambda} L \right) \right] \right\}, \quad (14)$$

which is the same as the expression found previously.

The moment exerted by the hinge may be found by summing moments at the hinge,

$$\sum \mathbf{M}_{\text{hinge}} = 0 = \mathbf{M}_{\text{hinge}} + \int_A \mathbf{r} \times d\mathbf{F}_p, \quad (15)$$

where

$$\mathbf{r} = x\hat{\mathbf{i}} + y\hat{\mathbf{j}}, \quad (16)$$

$$d\mathbf{F}_p = -pd\mathbf{A} = -\rho g(H-y)[dy(1)\hat{\mathbf{i}} - dx(1)\hat{\mathbf{j}}]. \quad (17)$$

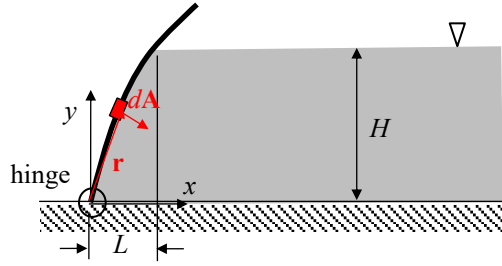

Substituting these relations into Eq. (15) and simplifying gives,

$$\mathbf{M}_{\text{hinge}} = - \int_A (x\hat{\mathbf{i}} + y\hat{\mathbf{j}}) \times -\rho g(H-y)[dy(1)\hat{\mathbf{i}} - dx(1)\hat{\mathbf{j}}] = \rho g\hat{\mathbf{k}} \int_A (H-y)(-xdx - ydy), \quad (18)$$

$$\mathbf{M}_{\text{hinge}} = -\rho g\hat{\mathbf{k}} \int_A (H-y)(xdx + ydy), \quad (19)$$

$$\mathbf{M}_{\text{hinge}} = -\rho g\hat{\mathbf{k}} \left\{ \int_{x=0}^{x=L} \left[H - a \sin\left(\frac{2\pi}{\lambda}x\right) \right] (xdx) + \int_{y=0}^{y=H} (H-y)(ydy) \right\}, \quad (20)$$

where Eq. (5) has been substituted in for \$y\$ in the first integral. Solving the integrals in the previous equation gives,

$$\mathbf{M}_{\text{hinge}} = -\rho g\hat{\mathbf{k}} \left\{ \frac{1}{2}HL^2 - \int_{x=0}^{x=L} a \sin\left(\frac{2\pi}{\lambda}x\right) x dx + \frac{1}{6}H^3 \right\}, \quad (21)$$

$$\mathbf{M}_{\text{hinge}} = -\rho g\hat{\mathbf{k}} \left\{ \frac{1}{2}HL^2 - \left[\left(\frac{\lambda}{2\pi}\right)^2 \sin\left(\frac{2\pi}{\lambda}x\right) - \left(\frac{\lambda}{2\pi}\right)x \cos\left(\frac{2\pi}{\lambda}x\right) \right]_{x=0}^{x=L} + \frac{1}{6}H^3 \right\}, \quad (22)$$

$$\mathbf{M}_{\text{hinge}} = -\rho g\hat{\mathbf{k}} \left\{ \frac{1}{2}HL^2 - \left(\frac{\lambda}{2\pi}\right)^2 \sin\left(\frac{2\pi}{\lambda}L\right) + \left(\frac{\lambda L}{2\pi}\right) \cos\left(\frac{2\pi}{\lambda}L\right) + \frac{1}{6}H^3 \right\}. \quad (23)$$