

A jet of water is deflected by a vane mounted on a cart. The water jet has an area, A , everywhere and is turned an angle θ with respect to the horizontal. The pressure everywhere within the jet is atmospheric. The incoming jet velocity with respect to the ground (axes XY) is V_{jet} . The cart has mass M . Determine:

- the force components, F_x and F_y , required to hold the cart stationary,
- the horizontal force component, F_x , if the cart moves to the right at the constant velocity, V_{cart} ($V_{\text{cart}} < V_{\text{jet}}$)
- the horizontal acceleration of the cart at the instant when the cart moves with velocity V_{cart} ($V_{\text{cart}} < V_{\text{jet}}$) if no horizontal forces are applied

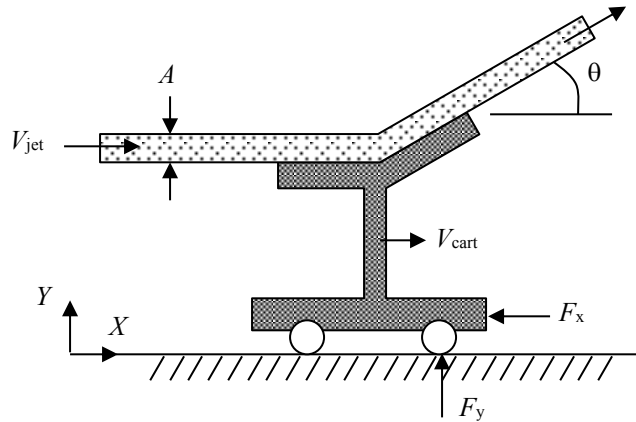

SOLUTION:

Part (a):

Apply conservation of mass and conservation of linear momentum to a control volume surrounding the cart. Use an inertial frame of reference fixed to the ground (XY).

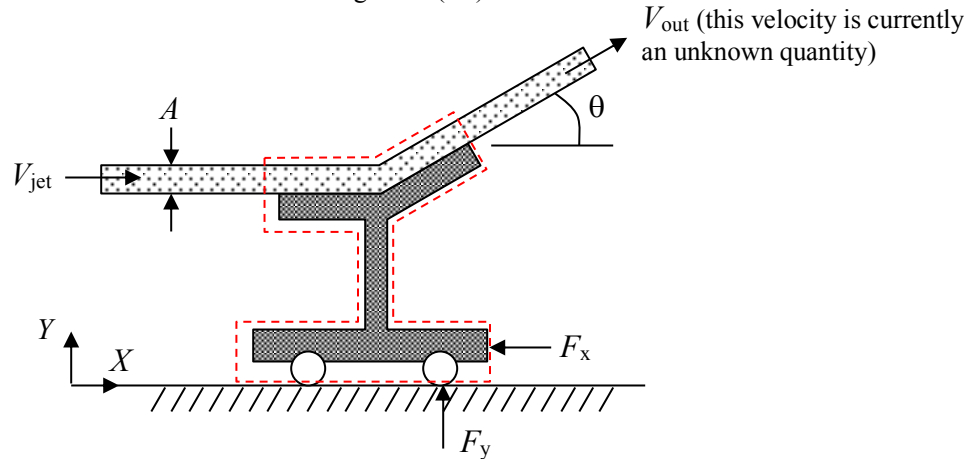

First apply conservation of mass to the control volume to determine V_{out} .

$$\frac{d}{dt} \int_{CV} \rho dV + \int_{CS} \rho \mathbf{u}_{rel} \cdot d\mathbf{A} = 0 \quad (1)$$

where

$$\frac{d}{dt} \int_{CV} \rho dV = 0 \quad (\text{the mass within the control volume doesn't change})$$

$$\int_{CS} \rho \mathbf{u}_{rel} \cdot d\mathbf{A} = \left[\rho V_{jet} \hat{\mathbf{i}} \cdot -A \hat{\mathbf{i}} \right] + \left[\rho V_{out} (\cos \theta \hat{\mathbf{i}} + \sin \theta \hat{\mathbf{j}}) \cdot A (\cos \theta \hat{\mathbf{i}} + \sin \theta \hat{\mathbf{j}}) \right]$$

left side right side

$$= -\rho V_{jet} A + \rho V_{out} A (\cos^2 \theta + \sin^2 \theta)$$

$$= -\rho V_{jet} A + \rho V_{out} A \quad =1$$

(Note that the jet area remains constant.)

Substitute and re-arrange.

$$-\rho V_{jet} A + \rho V_{out} A = 0$$

$$V_{out} = V_{jet} \quad (2)$$

Now apply conservation of linear momentum in the X -direction:

$$\frac{d}{dt} \int_{CV} u_X \rho dV + \int_{CS} u_X \rho \mathbf{u}_{rel} \cdot d\mathbf{A} = F_{B,X} + F_{S,X} \quad (3)$$

where

$$\frac{d}{dt} \int_{CV} u_X \rho dV = 0 \quad (\text{the momentum within the control volume doesn't change with time})$$

$$\int_{CS} u_X (\rho \mathbf{u}_{rel} \cdot d\mathbf{A}) = \underbrace{(V_{jet})}_{\text{left side}} \left(\underbrace{\rho V_{jet}}_{=\mathbf{u}_{rel}} \hat{\mathbf{i}} \cdot \underbrace{-A \hat{\mathbf{i}}}_{=\mathbf{A}} \right) + \underbrace{(V_{jet} \cos \theta)}_{=\mathbf{u}_X} \left[\underbrace{\rho V_{jet}}_{=\mathbf{u}_{rel}} (\cos \theta \hat{\mathbf{i}} + \sin \theta \hat{\mathbf{j}}) \cdot \underbrace{A (\cos \theta \hat{\mathbf{i}} + \sin \theta \hat{\mathbf{j}})}_{=\mathbf{A}} \right]_{\text{right side}}$$

$$= -\rho V_{jet}^2 A + \rho V_{jet}^2 A \cos \theta (\cos^2 \theta + \sin^2 \theta)$$

$$= \rho V_{jet}^2 A (\cos \theta - 1) \quad =1$$

$$F_{B,X} = 0 \quad (\text{no body forces in the } x\text{-direction})$$

$$F_{S,X} = -F_x \quad (\text{all of the pressure forces cancel out})$$

Substitute and re-arrange.

$$\rho V_{jet}^2 A (\cos \theta - 1) = -F_x$$

$$\boxed{F_x = \rho V_{jet}^2 A (1 - \cos \theta)} \quad (4)$$

Now look at the Y -direction:

$$\frac{d}{dt} \int_{CV} u_Y \rho dV + \int_{CS} u_Y \rho \mathbf{u}_{rel} \cdot d\mathbf{A} = F_{B,Y} + F_{S,Y} \quad (5)$$

where

$$\frac{d}{dt} \int_{CV} u_Y \rho dV = 0 \quad (\text{the momentum within the control volume doesn't change with time})$$

$$\int_{CS} u_Y (\rho \mathbf{u}_{rel} \cdot d\mathbf{A}) = \underbrace{(V_{jet} \sin \theta)}_{=\mathbf{u}_Y} \left[\underbrace{\rho V_{jet}}_{=\mathbf{u}_{rel}} (\cos \theta \hat{\mathbf{i}} + \sin \theta \hat{\mathbf{j}}) \cdot \underbrace{A (\cos \theta \hat{\mathbf{i}} + \sin \theta \hat{\mathbf{j}})}_{=\mathbf{A}} \right]_{\text{right side}}$$

$$= \rho V_{jet}^2 A \sin \theta (\cos^2 \theta + \sin^2 \theta)$$

$$= \rho V_{jet}^2 A \sin \theta \quad =1$$

$$F_{B,Y} = -Mg \quad (\text{assume that the fluid weight in the CV is negligible compared to the cart weight})$$

$$F_{S,Y} = F_y \quad (\text{all of the pressure forces cancel out})$$

Substitute and re-arrange.

$$\rho V_{jet}^2 A \sin \theta = -Mg + F_y$$

$$\boxed{F_y = \rho V_{jet}^2 A \sin \theta + Mg} \quad (6)$$

Part (b):

Apply conservation of linear momentum to a control volume surrounding the cart. Use a frame of reference fixed to the cart (xy). Note that this is an inertial frame of reference since the cart moves in a straight line at a constant speed. In addition, in this frame of reference, the cart appears stationary and the jet velocity at the left is equal to $V_{\text{jet}} - V_{\text{cart}}$.

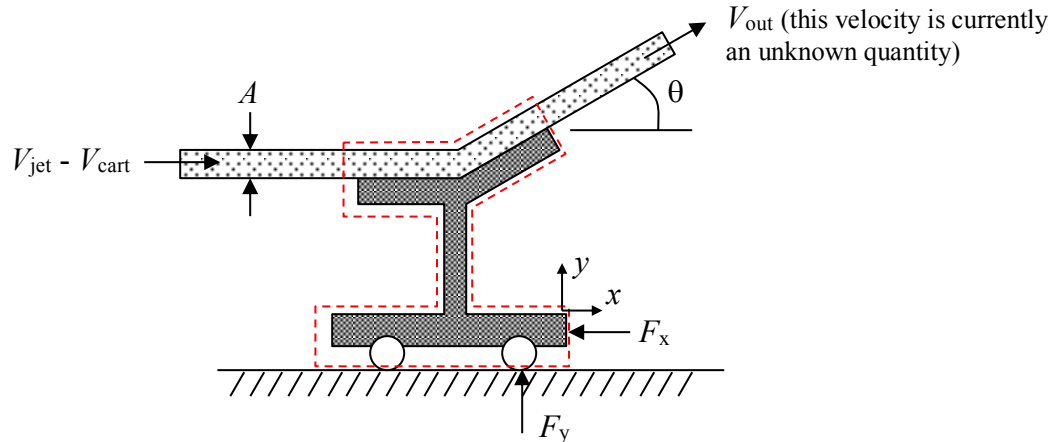

First apply conservation of mass to the control volume to determine V_{out}

$$\frac{d}{dt} \int_{\text{CV}} \rho dV + \int_{\text{CS}} \rho \mathbf{u}_{\text{rel}} \cdot d\mathbf{A} = 0 \quad (7)$$

where

$$\frac{d}{dt} \int_{\text{CV}} \rho dV = 0 \quad (\text{the mass within the control volume doesn't change})$$

$$\int_{\text{CS}} \rho \mathbf{u}_{\text{rel}} \cdot d\mathbf{A} = \left[\rho (V_{\text{jet}} - V_{\text{cart}}) \hat{\mathbf{i}} \cdot (-A \hat{\mathbf{i}}) \right] + \left[\rho V_{\text{out}} (\cos \theta \hat{\mathbf{i}} + \sin \theta \hat{\mathbf{j}}) \cdot A (\cos \theta \hat{\mathbf{i}} + \sin \theta \hat{\mathbf{j}}) \right]$$

left side right side

$$= -\rho (V_{\text{jet}} - V_{\text{cart}}) A + \rho V_{\text{out}} A (\cos^2 \theta + \sin^2 \theta)$$

=1

$$= -\rho (V_{\text{jet}} - V_{\text{cart}}) A + \rho V_{\text{out}} A$$

(Note that the jet area remains constant.)

Substitute and re-arrange.

$$-\rho (V_{\text{jet}} - V_{\text{cart}}) A + \rho V_{\text{out}} A = 0$$

$$V_{\text{out}} = V_{\text{jet}} - V_{\text{cart}} \quad (8)$$

Now apply conservation of linear momentum in the x -direction:

$$\frac{d}{dt} \int_{\text{CV}} u_x \rho dV + \int_{\text{CS}} u_x \rho \mathbf{u}_{\text{rel}} \cdot d\mathbf{A} = F_{B,x} + F_{S,x} \quad (9)$$

where

$$\frac{d}{dt} \int_{\text{CV}} u_x \rho dV = 0 \quad (\text{the momentum within the control volume doesn't change with time})$$

$$\begin{aligned} \int_{CS} u_x (\rho \mathbf{u}_{rel} \cdot d\mathbf{A}) &= \overset{=u_x}{(V_{jet} - V_{cart})} \left[\overset{=\mathbf{u}_{rel}}{\rho (V_{jet} - V_{cart}) \hat{\mathbf{i}} \cdot -A\hat{\mathbf{i}}} \overset{=\mathbf{A}}{\right]} + \overset{=u_x}{(V_{jet} - V_{cart}) \cos \theta} \left[\overset{=\mathbf{u}_{rel}}{\rho (V_{jet} - V_{cart}) (\cos \theta \hat{\mathbf{i}} + \sin \theta \hat{\mathbf{j}})} \overset{=\mathbf{A}}{A (\cos \theta \hat{\mathbf{i}} + \sin \theta \hat{\mathbf{j}})} \right] \\ &= -\rho (V_{jet} - V_{cart})^2 A + \rho (V_{jet} - V_{cart})^2 A \cos \theta (\cos^2 \theta + \sin^2 \theta) \\ &= \rho (V_{jet} - V_{cart})^2 A (\cos \theta - 1) \end{aligned}$$

$F_{B,x} = 0$ (no body forces in the x -direction)

$F_{S,x} = -F_x$ (all of the pressure forces cancel out)

Substitute and re-arrange.

$$\rho (V_{jet} - V_{cart})^2 A (\cos \theta - 1) = -F_x$$

$$\boxed{F_x = \rho (V_{jet} - V_{cart})^2 A (1 - \cos \theta)} \quad (10)$$

Now solve the problem using an inertial frame of reference fixed to the ground (frame XY). From Eqn. (8) we know that using a frame of reference fixed to the cart, the jet velocity on the right hand side is:

$$\mathbf{V}_{out, \text{relative to cart}} = (V_{jet} - V_{cart}) (\cos \theta \hat{\mathbf{i}} + \sin \theta \hat{\mathbf{j}}) \quad (11)$$

Hence, relative to the ground the jet velocity on the right hand side is:

$$\mathbf{V}_{out, \text{relative to ground}} = \mathbf{V}_{out, \text{relative to cart}} + \mathbf{V}_{cart} = (V_{jet} - V_{cart}) (\cos \theta \hat{\mathbf{i}} + \sin \theta \hat{\mathbf{j}}) + V_{cart} \hat{\mathbf{i}} \quad (12)$$

Now consider conservation of linear momentum in the X direction.

$$\frac{d}{dt} \int_{CV} u_x \rho dV + \int_{CS} u_x \rho \mathbf{u}_{rel} \cdot d\mathbf{A} = F_{B,x} + F_{S,x} \quad (13)$$

where

$$\frac{d}{dt} \int_{CV} u_x \rho dV = 0 \quad (\text{the momentum within the control volume doesn't change with time})$$

$$\begin{aligned} \int_{CS} u_x (\rho \mathbf{u}_{rel} \cdot d\mathbf{A}) &= \overset{=u_x}{V_{jet}} \left[\overset{=\mathbf{u}_{rel}}{\rho (V_{jet} - V_{cart}) \hat{\mathbf{i}} \cdot -A\hat{\mathbf{i}}} \overset{=\mathbf{A}}{\right]} + \overset{=u_x}{[(V_{jet} - V_{cart}) \cos \theta + V_{cart}]} \left[\overset{=\mathbf{u}_{rel}}{\rho (V_{jet} - V_{cart}) (\cos \theta \hat{\mathbf{i}} + \sin \theta \hat{\mathbf{j}})} \overset{=\mathbf{A}}{A (\cos \theta \hat{\mathbf{i}} + \sin \theta \hat{\mathbf{j}})} \right] \\ &= -\rho V_{jet} (V_{jet} - V_{cart}) A + \rho [(V_{jet} - V_{cart})^2 \cos \theta + V_{cart} (V_{jet} - V_{cart})] A (\cos^2 \theta + \sin^2 \theta) \\ &= \rho [-V_{jet}^2 + V_{jet} V_{cart} + (V_{jet} - V_{cart})^2 \cos \theta + V_{cart} V_{jet} - V_{cart}^2] A \\ &= \rho [(V_{jet} - V_{cart})^2 \cos \theta - (V_{jet} - V_{cart})^2] A \\ &= \rho (V_{jet} - V_{cart})^2 (\cos \theta - 1) A \end{aligned}$$

$F_{B,x} = 0$ (no body forces in the x -direction)

$F_{S,x} = -F_x$ (all of the pressure forces cancel out)

Substitute and re-arrange.

$$\rho (V_{jet} - V_{cart})^2 A (\cos \theta - 1) = -F_x$$

$$\boxed{F_x = \rho (V_{jet} - V_{cart})^2 A (1 - \cos \theta)} \quad (\text{Same answer as before!}) \quad (14)$$

Note that using a frame of reference that is fixed to the control volume is easier than using one fixed to the ground. This is often the case.

Part (c):

Apply conservation of linear momentum to a control volume surrounding the cart. Use a frame of reference fixed to the cart (xy). Note that this is not an inertial frame of reference since the cart is accelerating. As before, in this frame of reference the cart appears stationary and the jet velocity at the left is equal to $V_{\text{jet}} - V_{\text{cart}}$. Following the analysis given in part (b), conservation of mass indicates that the velocity on the right of the control volume is $V_{\text{jet}} - V_{\text{cart}}$.

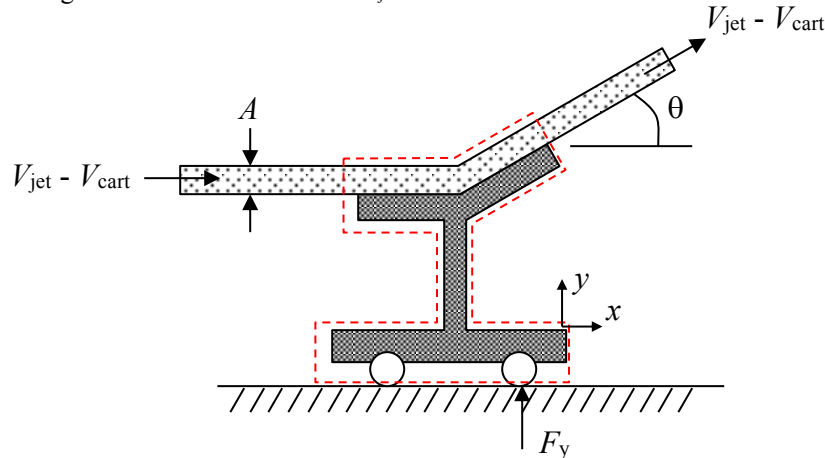

Apply conservation of linear momentum in the x -direction:

$$\frac{d}{dt} \int_{\text{CV}} u_x \rho dV + \int_{\text{CS}} u_x \rho \mathbf{u}_{\text{rel}} \cdot d\mathbf{A} = F_{B,x} + F_{S,x} - \int_{\text{CV}} a_{x/X} \rho dV \quad (15)$$

where

$$\frac{d}{dt} \int_{\text{CV}} u_x \rho dV \approx 0$$

(The cart has zero velocity in this frame of reference. The fluid in the control volume does accelerate in this frame of reference; however, its mass is assumed to be much smaller than the cart mass. Hence, the rate of change of the control volume momentum in this frame of reference is assumed to be zero.)

$$\begin{aligned} \int_{\text{CS}} u_x (\rho \mathbf{u}_{\text{rel}} \cdot d\mathbf{A}) &= \underbrace{(V_{\text{jet}} - V_{\text{cart}})}_{=u_x} \left[\underbrace{\rho (V_{\text{jet}} - V_{\text{cart}})}_{=\mathbf{u}_{\text{rel}}} \underbrace{\hat{\mathbf{i}} \cdot (-A\hat{\mathbf{i}})}_{=A} \right] + (V_{\text{jet}} - V_{\text{cart}}) \cos \theta \left[\underbrace{\rho (V_{\text{jet}} - V_{\text{cart}})}_{=\mathbf{u}_{\text{rel}}} (\cos \theta \hat{\mathbf{i}} + \sin \theta \hat{\mathbf{j}}) \cdot \underbrace{A (\cos \theta \hat{\mathbf{i}} + \sin \theta \hat{\mathbf{j}})}_{=A} \right] \\ &= -\rho (V_{\text{jet}} - V_{\text{cart}})^2 A + \rho (V_{\text{jet}} - V_{\text{cart}})^2 A \cos \theta (\cos^2 \theta + \sin^2 \theta) \\ &= \rho (V_{\text{jet}} - V_{\text{cart}})^2 A (\cos \theta - 1) \end{aligned}$$

$$F_{B,x} = 0 \quad (\text{no body forces in the } x\text{-direction})$$

$$F_{S,x} = 0 \quad (\text{all of the pressure forces cancel out})$$

$$\int_{\text{CV}} a_{x/X} \rho dV = Ma \quad (\text{the mass within the CV is approximately equal to the cart mass})$$

Substitute and re-arrange.

$$\rho (V_{\text{jet}} - V_{\text{cart}})^2 A (\cos \theta - 1) = -Ma$$

$$a = \frac{\rho (V_{\text{jet}} - V_{\text{cart}})^2 A (1 - \cos \theta)}{M} \quad (16)$$

Now solve the problem using an inertial frame of reference fixed to the ground (frame XY). The velocity out of the right side of the cart is given by Eqn. (12). Conservation of linear momentum in the X direction gives:

$$\frac{d}{dt} \int_{CV} u_X \rho dV + \int_{CS} u_X \rho \mathbf{u}_{rel} \cdot d\mathbf{A} = F_{B,X} + F_{S,X} \quad (17)$$

where

$$\frac{d}{dt} \int_{CV} u_X \rho dV \approx Ma$$

(The mass within the control volume is approximately equal to the cart mass since the fluid mass is assumed to be negligible.)

$$\begin{aligned} \int_{CS} u_X (\rho \mathbf{u}_{rel} \cdot d\mathbf{A}) &= \overset{=u_X}{V_{jet}} \left[\overset{=\mathbf{u}_{rel}}{\rho(V_{jet} - V_{cart})} \overset{=\mathbf{A}}{\hat{\mathbf{i}}} \cdot -A \hat{\mathbf{i}} \right] + \overset{=u_X}{\left[(V_{jet} - V_{cart}) \cos \theta + V_{cart} \right]} \left[\overset{=\mathbf{u}_{rel}}{\rho(V_{jet} - V_{cart})} (\cos \theta \hat{\mathbf{i}} + \sin \theta \hat{\mathbf{j}}) \cdot A (\cos \theta \hat{\mathbf{i}} + \sin \theta \hat{\mathbf{j}}) \right] \\ &\quad \text{left side} \qquad \qquad \qquad \qquad \qquad \text{right side} \\ &= -\rho V_{jet} (V_{jet} - V_{cart}) A + \rho \left[(V_{jet} - V_{cart})^2 \cos \theta + V_{cart} (V_{jet} - V_{cart}) \right] A (\cos^2 \theta + \sin^2 \theta) \\ &\qquad \qquad \qquad \qquad \qquad \qquad \qquad \qquad \qquad \qquad \qquad \qquad \qquad =1 \\ &= \rho \left[-V_{jet}^2 + V_{jet} V_{cart} + (V_{jet} - V_{cart})^2 \cos \theta + V_{cart} V_{jet} - V_{cart}^2 \right] A \\ &= \rho \left[(V_{jet} - V_{cart})^2 \cos \theta - (V_{jet} - V_{cart})^2 \right] A \\ &= \rho (V_{jet} - V_{cart})^2 (\cos \theta - 1) A \end{aligned}$$

$$F_{B,X} = 0 \quad (\text{no body forces in the } x\text{-direction})$$

$$F_{S,X} = 0 \quad (\text{all of the pressure forces cancel out})$$

Substitute and re-arrange.

$$Ma + \rho (V_{jet} - V_{cart})^2 A (\cos \theta - 1) = 0$$

$$\boxed{a = \frac{\rho (V_{jet} - V_{cart})^2 A (1 - \cos \theta)}{M}} \quad (\text{Same answer as before!}) \quad (18)$$

As in part (b), using a frame of reference that is fixed to the control volume is easier than using one fixed to the ground.