

Adaptive Robust Motion and Force Tracking Control of Robot Manipulators in Contact With Compliant Surfaces With Unknown Stiffness¹

Bin Yao

Assistant Professor,
School of Mechanical Engineering,
Purdue University,
West Lafayette, IN 47907

Masayoshi Tomizuka

Roscoe and Elizabeth Hughes Professor,
Mechanical Engineering Department,
University of California at Berkeley,
Berkeley, CA 94720. Fellow ASME

High performance robust motion and force tracking control of robot manipulators in contact with compliant surfaces is considered in this paper. The robot parameters and the stiffness of the contact surface may not be known. The system may also be subjected to uncertain nonlinearities coming from the joint friction of the robot, external disturbances, the contact surface friction model, and the unknown time-varying equilibrium position of the contact surface. An adaptive robust motion and force tracking controller is proposed, which needs measurements of position, velocity, and interaction force only. The controller achieves a guaranteed transient performance and final tracking accuracy, a desirable feature for applications and for maintaining contact. In addition, the controller achieves asymptotic motion and force tracking without resorting to high-gain feedback when the system is subjected to parametric uncertainties.

I Introduction

Applications such as contour following, grinding, deburring, as well as assembly related tasks involve the end-effector of a robot in contact with its environment. To execute these tasks successfully (e.g., avoiding tool or workpiece damage), it is necessary to control both motion of the robot and the contact force between the end-effector and the environment. Depending on the type of contact environment, different objectives and approaches have been proposed, such as impedance control [1, 2], constrained motion control [3-7], and hybrid position/force control [8, 9]. In constrained motion control [3-7], contact surfaces are assumed to be rigid, which is justified for very stiff surfaces when the deformation of the surface is negligibly small and the motion along normal direction of the contact surface is well damped to be neglected for control purpose. In contrast, this paper focuses on tasks in which the end-effector contacts with a compliant surface [9, 10] where the deformation of the surface has noticeable effect on contact force and/or the motion along the normal direction of the surface is not well damped and has to be considered in the controller design stage.

Practically, parameters of the system such as gravitational load and the stiffness of the contact surface vary from a task to another, and, hence, may not be precisely known in advance. The system may also be subjected to uncertain nonlinearities coming from the joint friction of the robot, the friction and the unknown equilibrium position of the contact surface, etc. These uncertainties make it difficult to solve the motion and force tracking control problem. Unavailability of the time derivative of contact force further complicates the problem. Although there are a number of papers dealing with the constrained motion control [3-7], only a few papers [9, 10, 11] were published to address the motion and force tracking control of robot manipulators in contact with compliant surfaces.

Yao et al. [9] developed a variable structure adaptive (VSA) method. The resulting VSA control law was discontinuous and chattering was a problem. Subsequently, Yao and Tomizuka developed a robust adaptive motion and force control algorithm in [11] to solve the chattering problem. However, transient performance and final tracking accuracy were not guaranteed, and the effect of time-varying equilibrium position and that of time-varying stiffness of the contact surface were not considered.

Recently, Yao and Tomizuka proposed a new approach, adaptive robust control (ARC) [12-15], for high performance robust control of uncertain nonlinear systems in the presence of both parametric uncertainties and uncertain nonlinearities. The approach effectively combines the design techniques of adaptive control (AC) and those of deterministic robust control (DRC) (e.g., sliding mode control [16], SMC) and improves performance by preserving the advantages of both AC and DRC. Specifically, through proper controller structure as in DRC [17], the proposed ARC achieves a guaranteed performance in terms of both the transient error and the final tracking accuracy in the presence of both parametric uncertainties and uncertain nonlinearities. This result overcomes the drawbacks of poor transient and poor robustness to uncertain nonlinearities of adaptive control (AC) [18-21], and makes the approach attractive from the view point of applications. Through parameter adaptation as in adaptive control, the proposed ARC achieves asymptotic tracking in the presence of parametric uncertainties without resorting to a discontinuous control law [16] or an infinite gain in the feedback loop [22], which implies that the system is free of control chattering. In other words, the approach eliminates the effect of parametric uncertainties and, thus, achieves a better tracking performance than DRC. The design is conceptually simple and amenable to implementation. Comparative experimental results for trajectory tracking control of robot manipulators [13, 23] have shown the advantages of the proposed ARC and the improvement of performance. A general framework of the proposed ARC is formulated in terms of adaptive robust control (ARC) Lyapunov functions [15, 23]. Through the backstepping design, ARC Lyapunov functions have been success-

¹ Part of the paper was presented at the 1996 ASME Congress Symposium on Nonlinear Dynamics and Control.

Contributed by the Dynamic Systems and Control Division for publication in the JOURNAL OF DYNAMIC SYSTEMS, MEASUREMENT, AND CONTROL. Manuscript received by the DSCD September 15, 1996. Associate Technical Editor: J. E. Colgate.

fully constructed for a large class of multi-input multi-output (MIMO) nonlinear systems transformable to semi-strict feedback forms [15, 23].

In this paper, it will be shown that the robot equation for the motion and force tracking control in contact with compliant surfaces with unknown time-varying stiffness and time-varying equilibrium position can be converted into a form similar to the semi-strict feedback form in [15] with a "relative degree" two. The synthesis technique is thus qualitatively different from existing robust motion and force control algorithms [5, 6, 7, 12, 13, 4] where the design is essentially for a "relative degree" one system. The ARC design technique [15] is applied with consideration of the particular structure and properties of the robot. Instead of the smooth projection used in the previous ARC design [15, 23], a simple continuous projection is also developed to solve the conflicts between the adaptive control design and robust control design. The resulting controller achieves a guaranteed transient performance and final tracking accuracy for both motion and force tracking. This property is vital for avoiding loss of contact. Asymptotic motion and force tracking is also achieved in the presence of parametric uncertainties only. Only measurements of position, velocity, and interaction force are needed.

II Problem Formulation and Model

In a Cartesian coordinate system, let $x \in R^n$ denote the vector of the position/orientation of the robot end-effector and $F \in R^n$ the vector of interaction forces/moments on the environment exerted by the robot at the end-effector. Suppose that the undeformed environment is described by a set of m hypersurfaces [9]

$$\Phi(x, t) = \Phi_e(t)$$

$$\Phi(x, t) = [\phi_1(x, t), \dots, \phi_m(x, t)]^T \quad m \leq n \quad (1)$$

which are mutually independent for any t . $\Phi_e(t) = [\phi_{e1}, \dots, \phi_{em}]^T$ represents the equilibrium position of the undeformed environment and is unknown. Suppose that there exists a set of $(n - m)$ scalar functions $\{\psi_1(x, t), \dots, \psi_{n-m}(x, t)\}$ such that $\{\phi_i(x, t); \psi_j(x, t)\}$ are mutually independent for any t . The task space is defined as [9]

$$r = [r_f^T, r_p^T]^T \quad r_f = [\phi_1(x, t), \dots, \phi_m(x, t)]^T \in R^m$$

$$r_p = [\psi_1(x, t), \dots, \psi_{n-m}(x, t)]^T \in R^{n-m} \quad (2)$$

In defining the task space (2), the directions of curvilinear coordinates r_f are aligned with the normal directions (assumed to be outer normal directions) of the undeformed surfaces. Therefore, force tracking control is required along r_f coordinates. The rest curvilinear coordinates r_p represent the motion of the end-effector along the contact surfaces, in which motion control is needed. Along the normal directions of contact surfaces, the environment is assumed to be represented by an elastic model with an unknown time-varying symmetric positive definite (s.p.d.) stiffness matrix $K_e(t)$, i.e.,

$$f_n = K_e(t)(r_f - r_{fe}(t)) \text{ or } r_f = K_f(t)f_n + r_{fe}, \quad f_n \leq 0 \quad (3)$$

where $f_n \in R^m$ is the vector of normal contact force components, $r_{fe}(t) = \Phi_e(t)$ represents the unknown equilibrium position, and $K_f(t) = K_e^{-1}$ is an unknown s.p.d. compliance matrix. Since the contact surfaces are unilateral, $f_n \leq 0$.² It is assumed that the end-effector is initially in contact with the surfaces, and that $f_n \leq 0$ is never violated after the control torque is applied, i.e., contact is never lost. If the exact force tracking control can be achieved and the transient response of force tracking can be guaranteed, which will be the case of the proposed controller,

the assumption that $f_n \leq 0$ can be justified since the desired force trajectory must satisfy the condition that $f_{nd} < 0$.

By using the same technique as in [9], the robot dynamic equation in the task space can be obtained as [23]

$$M(r, t, \beta)\ddot{r} + C(r, \dot{r}, t, \beta)\dot{r} + G(r, t, \beta) + D_t(r, \dot{r}, t, \beta) + \tilde{f} + F_r = u_r \quad (4)$$

where M , C , and G represent the inertia matrix, the Coriolis and centrifugal force, and the gravitational force, respectively, D_t is due to the time-varying nature of the transformation (2), \tilde{f} represents the vector of unknown nonlinear functions due to external disturbances and joint friction, etc., F_r is the interaction force, $\beta \in R^l$ is the vector of a suitably selected set of robot parameters, and u_r is the control input. F_r can be written as

$$F_r = L_r(\mu, r, \dot{r}, t)f_n + \tilde{L}_r(r, \dot{r}, t)f_n \quad (5)$$

where $L_r f_n$ represents the modeled interaction force including surface friction force, and $\tilde{L}_r f_n$ represents the modeling error. L_r can be linearly parametrized in terms of the unknown friction coefficients $\mu \in R^k$, i.e.,

$$L_r(\mu, r, \dot{r}, t)f_n = f_\mu(r, \dot{r}, f_n, t) + Y_\mu(r, \dot{r}, f_n, t)\mu \quad (6)$$

where f_μ and Y_μ are known.³ The following properties can be obtained for (4) by using the same techniques as in [24].

Property 1. For the finite workspace Ω_q in which all kinematic transformations are well defined, $M(r, t, \beta)$ is an s.p.d. matrix with $k'_r I_n \leq M(r, t, \beta) \leq k''_r I_n$, where k'_r and k''_r are some positive constants and I_n represents an $n \times n$ identity matrix. \diamond

Property 2. The matrix $\dot{M}(r, t, \beta) - 2C(r, \dot{r}, t, \beta)$ is a skew-symmetric matrix. \diamond

Property 3. $M(r, t, \beta)$, $C(r, \dot{r}, t, \beta)$, $G(r, t, \beta)$, and $D_t(r, \dot{r}, t, \beta)$ can be linearly parametrized in terms of β , i.e.,

$$Mz_v + Cz_r + G + D_t = f_\beta(r, \dot{r}, z_r, z_v, t) + Y_\beta(r, \dot{r}, z_r, z_v, t)\beta \quad (7)$$

where z_r and z_v are any reference values, and f_β and Y_β are known. \diamond

Denote the set of independent unknown parameters of K_f as $\theta(t) \in R^{k_\theta}$. Because of the symmetry of K_f , $k_\theta \leq 1/2m(m + 1)$. Then, for any vector \bullet , since K_f is linear w.r.t. θ , we can write

$$K_f(t)\bullet = f_\theta(\bullet) + Y_\theta(\bullet)\theta(t) \quad (8)$$

where f_θ and Y_θ are known. We make the following reasonable assumptions on the parametric uncertainties and the modeling error.

Assumption 1. $\beta \in \Omega_\beta \triangleq \{\beta: \beta_{\min} < \beta < \beta_{\max}\}$ and $\theta(t) \in \Omega_\theta \triangleq \{\theta: \theta_{\min} < \theta < \theta_{\max}\}$, where Ω_β and Ω_θ are known sets. \diamond

Assumption 2. The modeling error is bounded by some known functions and the derivatives of $\Phi_e(t)$ and $\theta(t)$ are bounded, i.e.,

$$\|\tilde{f}(r, \dot{r}, t) + \tilde{L}_r(r, \dot{r}, t)f_n\| \leq \delta_r(r, \dot{r}, f_n, t)$$

$$\|\dot{\Phi}_e(t)\| \leq \delta_e, \quad \|\dot{\theta}(t)\| \leq \delta_\theta \quad (9)$$

where δ_r is a known function and δ_e and δ_θ are known.

Note that when Φ_e and θ are unknown but constant as studied in [11], $\dot{\Phi}_e = 0$, $\dot{\theta} = 0$, and the last two equations of (9) are trivially satisfied.

²The operation \leq for vectors is defined in terms of their corresponding elements.

³A function is called known if it is a known function with respect to (w.r.t.) their variables.

Suppose that $r_{pd}(t) \in R^{n-m}$ is given as the desired motion trajectory in the unconstrained subspace and $f_{nd}(t) \in R^m$ is the desired force trajectory in the constrained subspace. The objective is to design a control law and some parameter adaptation laws under Assumptions 1 and 2 such that the motion and force tracking errors, $e_{pa} = r_p(t) - r_{pd}(t) \in R^{n-m}$ and $e_{fa} = f_n(t) - f_{nd}(t) \in R^m$, are as small as possible.

III ARC Motion and Force Control

In this section, the ARC design technique [15] is applied to solve the above robust motion and force tracking control problem.

3.1 Semi-Strict Feedback Form. Define state variables as

$$\begin{aligned} x_1 &= [x_{1,1}^T, x_{1,2}^T]^T, \quad x_{1,1} = f_n, \quad x_{1,2} = r_p \\ x_2 &= \dot{r} \end{aligned} \quad (10)$$

Noting (3), (4), and (5), the system can be represented by

$$\begin{aligned} \dot{x}_1 &= B_1 x_2 + D_1 \Delta_1 \\ \dot{x}_2 &= M^{-1}(r, t, \beta)[-C(r, x_2, t, \beta)x_2 - G(r, t, \beta) \\ &\quad - D_t(r, x_2, t, \beta) - L_r(\mu, r, x_2, t)x_{1,1} + u_r + \Delta_2] \\ y &= x_1 \end{aligned} \quad (11)$$

where

$$\begin{aligned} B_1 &= \begin{bmatrix} K_e & 0 \\ 0 & I_{n-m} \end{bmatrix}, \quad D_1 = [I_m \quad 0]^T \\ \Delta_1 &= \dot{K}_e(t)(r_f - \Phi_e) - K_e \dot{\Phi}_e(t), \\ \Delta_2 &= -\tilde{f}(r, x_2, t) - \tilde{L}_r(r, x_2, t)x_{1,1} \end{aligned} \quad (12)$$

The first equation of (11) has parametric uncertainties in B_1 and uncertain nonlinearities in Δ_1 . These uncertainties are mismatched uncertainties since the control input u_r appears in the second equation. The appearance of mismatched uncertainties makes the controller design complicated. Since r and \dot{r} are measurable, we may treat r in the second equation of (11) as a known quantity.⁴ Then, noting Assumptions 1 and 2, and Properties 1 and 3, (11) is similar to the semi-strict feedback form in [15] with a "relative degree" of two. Thus, in principle, we may be able to apply the general results in [15] to obtain an ARC controller. However, in order to take into account of the special structure of the robot dynamics, we proceed the design in the following way. The design parallels the recursive backstepping design procedure in [15]. An ARC Lyapunov function is first constructed for the first equation of (11). Then, using the backstepping design, an ARC Lyapunov function is found for the whole system.

The first equation of (11) is actually made of two decoupled equations, i.e., the force equation

$$\dot{f}_n = K_e x_{2,1} + \Delta_1 \quad (13)$$

and the motion equation

$$\dot{r}_p = x_{2,2} \quad (14)$$

Thus, in the following, ARC Lyapunov functions will be constructed for the force and motion equations separately. Furthermore, instead of tracking $r_{pd}(t)$ and $f_{nd}(t)$ directly, the controller is designed to track the filtered desired motion and force trajectories, $r_{pr}(t)$ and $f_{nr}(t)$, each created by a second-

order stable system. Such a procedure enables us to choose the initial conditions, $r_{pr}(0)$, $\dot{r}_{pr}(0)$, $f_{nr}(0)$, and $\dot{f}_{nr}(0)$, freely to guarantee transient performance as in [14]. In practice, whenever the system tracking error experiences a sudden jump due to some discontinuous perturbations, such a desired trajectory initialization can be adopted to minimize the transient response as done in [25] for eliminating reaching transient by suitably choosing initial conditions. In the following, let $e_p = r_p - r_{pr}$ and $e_f = f_n - f_{nr}$ be the motion and force tracking errors, respectively.

3.2 Notations and Smooth Projection. Let $\hat{\bullet}$ denote the estimate of \bullet (e.g., $\hat{\theta}$ for θ) and \bullet_i the i -th component of \bullet . For any unknown parameter vector \bullet lying in a known bounded region $\Omega_\bullet = \{\bullet : \bullet_{\min} < \bullet < \bullet_{\max}\}$ (e.g., Ω_θ), a simple smooth projection map π can be defined for $\hat{\bullet}$ and satisfies the following properties: (a). $\forall \hat{\bullet} \in \Omega_\bullet, \pi(\hat{\bullet}) = \hat{\bullet}$; (b). $\forall \hat{\bullet}, \pi(\hat{\bullet}) \in \Omega_\bullet = \{\hat{\bullet}_\pi : \bullet_{\min} - \epsilon_\bullet \leq \hat{\bullet}_\pi \leq \bullet_{\max} + \epsilon_\bullet\}$ where ϵ_\bullet is a known vector of positive numbers that can be arbitrarily small; (c). $\pi_i(\hat{\bullet}_i)$ is a nondecreasing function of $\hat{\bullet}_i$; and (d). The derivatives of the projection are bounded up to a sufficiently high-order. See [14] for further details. For convenience, define $\hat{\bullet}_\pi$ as $\hat{\bullet}_\pi = \pi(\hat{\bullet})$ and the projected estimation error as $\tilde{\bullet}_\pi = \hat{\bullet} - \hat{\bullet}_\pi$.

3.3 Force ARC Lyapunov Function. In this subsection, a force control function u_f will be constructed for $x_{2,1}$ such that force tracking control will be achieved with a guaranteed transient performance if $x_{2,1} = u_f$. This is achieved by constructing an ARC Lyapunov function V_f as follows.

Recent one-dimensional force experimental results [26] have shown that integral force feedback control has some advantages since it has a stronger robustness to the measurement time delay and can remove steady state force tracking error. For this reason, we introduce the integral of force tracking error, $I_f = I_f(0) + \int_0^t e_f(\nu) d\nu$, in the design. Also, since K_e is an s.p.d. matrix, it will be easier to design a control law based on the estimate of $K_f = K_e^{-1}$ instead of the estimate of K_e . Considering these factors, from (13), equations for I_f and the force are

$$\begin{aligned} \dot{I}_f &= e_f = f_n - f_{nr}(t) \\ K_f \dot{f}_n &= x_{2,1} + \tilde{\Delta}_1, \quad \tilde{\Delta}_1 = K_e^{-1} \dot{K}_e(r_f - \Phi_e) - \dot{\Phi}_e \end{aligned} \quad (15)$$

Define a switching-function-like vector ξ_f as

$$\xi_f = e_f + D_1 I_f \quad (16)$$

where D_1 is an s.p.d. matrix. By choosing the initial value of I_f as $I_f(0) = D_1^{-1} e_f(0)$, we have

$$\xi_f(0) = e_f(0) + D_1 I_f(0) = 0 \quad (17)$$

From (16), we note

$$\dot{\xi}_f = \dot{f}_n - \epsilon, \quad \epsilon \triangleq \dot{f}_{nr} - D_1 e_f \quad (18)$$

Choose a positive semi-definite (p.s.d.) function V_f as

$$V_f = \frac{1}{2} w_f \xi_f^T K_f \xi_f \quad (19)$$

where $w_f > 0$ is any weighting factor.

Lemma 1. Let the control law for $x_{2,1}$ be

$$u_f(\epsilon, \xi_f, \hat{\theta}_\pi, t) = u_{fa}(\epsilon, \xi_f, \hat{\theta}_\pi) + u_{fs}(\epsilon, \xi_f, \hat{\theta}_\pi, t) \quad (20)$$

where

$$u_{fa} = \hat{K}_f \epsilon - D_2 \xi_f = f_\theta(\epsilon) + Y_\theta(\epsilon) \hat{\theta}_\pi - D_2 \xi_f \quad (21)$$

⁴ Otherwise, we have to write r as a function of x_1 . The relationship $r(x_1)$ is unknown because of the unknown stiffness and the unknown equilibrium. Then, terms like $M(r(x_1), t, \beta)$ cannot be linearly parametrized.

and u_{fs} is any vector of differentiable functions satisfying the following two conditions

$$i. \xi_f^T u_{fs} \leq 0$$

$$ii. \xi_f^T (\tilde{\Delta}_1 + \frac{1}{2} \dot{K}_f \xi_f + Y_\theta(\epsilon) \tilde{\theta}_\pi) + \xi_f^T u_{fs} \leq \epsilon_f \quad (22)$$

in which $\epsilon_f > 0$ is a design parameter, $D_2 > 0$, and $\tilde{\theta}_\pi$ is the projection of $\hat{\theta}$ defined in Subsection 3.2. Then, we have
(a) In general,

$$\dot{V}_f|_{u_f} \leq -\lambda_{V_f} V_f + w_f \epsilon_f \quad (23)$$

where $\lambda_{V_f} = (2\lambda_{\min}(D_2)/\sup_t \{\lambda_{\max}(K_f)(t)\})$, and $\dot{V}_f|_{u_f}$ denote \dot{V}_f under the condition that $x_{2,1} = u_f$.

(b) In addition, when $\tilde{\Delta}_1 = 0$ and $\dot{K}_e = 0$,

$$\dot{V}_f|_{u_f} \leq -w_f \xi_f^T D_2 \xi_f + \tau_f^T \tilde{\theta}_\pi \quad (24)$$

where

$$\tau_f = w_f Y_\theta^T(\epsilon) \xi_f \quad (25)$$

◇

Remark 1. Lemma 1 shows that V_f is an ARC Lyapunov function [15] for (15) with the control function given by (20) and the adaptation function given by (25).

Proof: Noting (8), (15), and (18), the derivative of V_f is

$$\begin{aligned} \dot{V}_f &= w_f \xi_f^T (K_f \dot{\xi}_f + \frac{1}{2} \dot{K}_f \xi_f) = w_f \xi_f^T (K_f \dot{f}_n - K_f \epsilon + \frac{1}{2} \dot{K}_f \xi_f) \\ &= w_f \xi_f^T [x_{2,1} + \tilde{\Delta}_1 - f_\theta(\epsilon) - Y_\theta(\epsilon) \theta + \frac{1}{2} \dot{K}_f \xi_f] \quad (26) \end{aligned}$$

If $x_{2,1} = u_f$, then,

$$\begin{aligned} \dot{V}_f|_{u_f} &= -w_f \xi_f^T D_2 \xi_f \\ &+ w_f \xi_f^T [\tilde{\Delta}_1 + \frac{1}{2} \dot{K}_f \xi_f + Y_\theta(\epsilon) \tilde{\theta}_\pi + u_{fs}] \quad (27) \end{aligned}$$

which leads to (23) by noting *ii* of (22).

When $\tilde{\Delta}_1 = 0$ and $\dot{K}_e = 0$, $\dot{K}_f = 0$ and (27) leads to (24) by noting *i* of (22).

3.4. Motion ARC Lyapunov Function As above, in this subsection, a motion control function u_p will be constructed for $x_{2,2}$ such that motion tracking control will be achieved with a guaranteed transient performance if $x_{2,2} = u_p$. Since the position Eq. (14) has no modeling uncertainties, we can use the technique in designing dynamic sliding mode in [12] to obtain a stabilizing control for it. Namely, let a switching-function-like vector be

$$\xi_p = \dot{e}_p + y_p, \quad \xi_p \in R^{(n-m)} \quad (28)$$

where y_p is the output of a n_p -th order dynamic compensator given by

$$\begin{aligned} \dot{z}_p &= A_p z_p + B_p e_p, \quad z_p \in R^{n_p} \\ y_p &= C_p z_p + D_p e_p, \quad y_p \in R^{(n-m)} \quad (29) \end{aligned}$$

(A_p, B_p, C_p, D_p) is required to be controllable and observable. Transfer function from ξ_p to e_p is

$$e_p = G_{\xi_p}^{-1}(s) \xi_p \quad (30)$$

where

$$\begin{aligned} G_{\xi_p}(s) &= sI_n + G_c(s), \\ G_c(s) &= C_p(sI_{n_p} - A_p)^{-1} B_p + D_p \quad (31) \end{aligned}$$

Thus, by suitably choosing the dynamic compensator transfer function $G_c(s)$, the transfer function $G_{\xi_p}^{-1}(s)$ can be arbitrarily

assigned as long as $G_{\xi_p}^{-1}(s)$ has a relative degree. A state space realization of $G_{\xi_p}^{-1}(s)$ has the state x_{ξ_p} and the following representation

$$\begin{aligned} \dot{x}_{\xi_p} &= A_{\xi_p} x_{\xi_p} + B_{\xi_p} \xi_p, \quad y_{\xi_p} = C_{\xi_p} x_{\xi_p} \\ A_{\xi_p} &= \begin{bmatrix} A_p & B_p \\ -C_p & -D_p \end{bmatrix}, \quad B_{\xi_p} = \begin{bmatrix} 0 \\ I_{n-m} \end{bmatrix} \\ C_{\xi_p} &= [0 \quad I_{n-m}] \quad (32) \end{aligned}$$

In state space, the result equivalent to the transfer function $G_{\xi_p}^{-1}(s)$ being arbitrarily assigned can be stated as follows: the following Lyapunov equation has an s.p.d. solution P_{ξ_p} for any s.p.d. matrix Q_{ξ_p}

$$A_{\xi_p}^T P_{\xi_p} + P_{\xi_p} A_{\xi_p} = -Q_{\xi_p} \quad (33)$$

Furthermore, $\lambda_{V_p} \triangleq (\lambda_{\min}(Q_{\xi_p})/\lambda_{\max}(P_{\xi_p}))$ can be arbitrarily large value by assigning the poles of A_{ξ_p} to the far left plane to obtain any exponentially fast converging rate.

Lemma 2. Let the control law for $x_{2,2}$ be

$$u_p = \dot{r}_{pr}(t) - y_p \quad (34)$$

Then, the positive definite (p.d.) function defined by

$$V_p = \frac{1}{2} x_{\xi_p}^T P_{\xi_p} x_{\xi_p} \quad (35)$$

is a Lyapunov function or an ARC Lyapunov function for the motion subsystem, i.e.,

$$\dot{V}_p|_{u_p} \leq -\lambda_{V_p} V_p \quad (36)$$

Proof: If $x_{2,2} = u_p$, from (28), we have

$$\xi_p = x_{2,2} - (\dot{r}_{pr} + y_p) = 0 \quad (37)$$

Noting (32) and (33), (36) is obvious. □

3.5 Backstepping Design Via ARC Lyapunov Function.

In the previous subsections, we have shown that if x_2 takes the feedback law $u_{1d} = [u_f^T, u_p^T]^T$ given by (20) and (34), we can achieve motion and force tracking as demonstrated in Lemmas 1 and 2. So the backstepping design in this section is to design an ARC law for the second equation of (11) so that its output x_2 tracks its desired value u_{1d} with the transient performance we want. This process can be completed by making the following p.s.d. function an ARC Lyapunov function:

$$V = V_f + V_p + \frac{1}{2} z_2^T M(r, t, \beta) z_2 \quad (38)$$

where $z_2 = x_2 - u_{1d} = \dot{r} - u_{1d}$ is the tracking error for the second equation. Noting that $\dot{e} = \dot{f}_{nr} + D_1 \dot{f}_{nr} - D_1 \dot{f}_n$ and $\dot{\xi}_f = \dot{f}_n - \epsilon$, by differentiating (20), we can write

$$\begin{aligned} \dot{u}_f &= Y_1(\epsilon, \xi_f, \bar{\theta}_\pi^{(1)}, t) + Y_2(\epsilon, \xi_f, \hat{\theta}_\pi, t) \dot{f}_n \\ &+ \frac{\partial u_f}{\partial \hat{\theta}} (\dot{\hat{\theta}} - P_\theta(\epsilon, \xi_f, \hat{\theta}, t)) \quad (39) \end{aligned}$$

where P_θ is a bounded function w.r.t. $\hat{\theta}$ which will be specified later. Y_1 and Y_2 are calculable and given by

$$\begin{aligned} Y_1 &= \frac{\partial u_f}{\partial \epsilon} (\dot{f}_{nr} + D_1 \dot{f}_{nr}) - \frac{\partial u_f}{\partial \xi_f} \epsilon + \frac{\partial u_f}{\partial \hat{\theta}} P_\theta + \frac{\partial u_f}{\partial t} \\ Y_2 &= -\frac{\partial u_f}{\partial \epsilon} D_1 + \frac{\partial u_f}{\partial \xi_f} \quad (40) \end{aligned}$$

Noting (13), u_{1d} can be decomposed into the following terms

$$\dot{u}_{1d} = z_v + \begin{bmatrix} Y_2 \\ 0 \end{bmatrix} (K_e \dot{r}_f + \Delta_1) + \begin{bmatrix} \frac{\partial u_f}{\partial \theta} \\ 0 \end{bmatrix} (\dot{\theta} - P_\theta) \quad (41)$$

where

$$z_v = \begin{bmatrix} Y_1(\epsilon, \xi_f, \bar{\theta}_\pi^{(1)}, t) \\ \dot{u}_p \end{bmatrix} \quad (42)$$

z_v is calculable based on the measurements of position, velocity, and force only. Noting that M is linear w.r.t. β , there exists known $Y_3(r, \epsilon, \xi_f, \bar{\theta}_\pi, \dot{r}_f, t)$ and $Y_\vartheta(r, \epsilon, \xi_f, \bar{\theta}_\pi, \dot{r}_f, t)$ such that

$$M(r, t, \beta) \begin{bmatrix} Y_2(\epsilon, \xi_f, \bar{\theta}_\pi, t) K_e \dot{r}_f \\ 0 \end{bmatrix} = Y_3 + Y_\vartheta \vartheta \quad (43)$$

where ϑ represents a set of suitably selected unknown constants whose elements are the products of the elements of β and K_e . In view of Assumption 1, $\vartheta \in \Omega_\vartheta$, where Ω_ϑ is a known bounded set and is denoted by $\Omega_\vartheta = \{\vartheta: \vartheta_{\min} < \vartheta < \vartheta_{\max}\}$. So we can define $\hat{\vartheta}_\pi = \pi_\vartheta(\hat{\vartheta})$, the projection of $\hat{\vartheta}$, in the same way as in Subsection 3.2.

Lemma 3. Let the control law for u_r be

$$u_r = u_{ra} + u_{rs}$$

$$\begin{aligned} u_{ra} = & f_\beta(r, \dot{r}, u_{1d}, z_v, t) + Y_\beta(r, \dot{r}, u_{1d}, z_v, t) \hat{\beta}_\pi \\ & + f_\mu(r, \dot{r}, f_n, t) + Y_\mu(r, \dot{r}, f_n, t) \hat{\mu}_\pi \\ & + Y_3 + Y_\vartheta \hat{\vartheta}_\pi - u'_r - K_z z_2 \end{aligned}$$

$$u'_r = \begin{bmatrix} w_f \xi_f \\ B_{\xi_p}^T P_{\xi_p} x_{\xi_p} \end{bmatrix} \quad (44)$$

where $K_z > 0$ and u_{rs} is any vector of continuous functions satisfying the following two conditions

$$(i) \quad z_2^T u_{rs} \leq 0$$

$$(ii) \quad z_2^T [Y_\beta \hat{\beta}_\pi + Y_\mu \hat{\mu}_\pi + Y_\vartheta \hat{\vartheta}_\pi + \tilde{\Delta}_2] + z_2^T u_{rs} \leq \varepsilon_z \quad (45)$$

in which $\varepsilon_z > 0$ is a design parameter and

$$\tilde{\Delta}_2 = -M \begin{bmatrix} Y_2 \\ 0 \end{bmatrix} \Delta_1 + \Delta_2 \quad (46)$$

Then, the following results can be obtained:

(a.) In general,

$$\dot{V} \leq -\lambda_V V + \varepsilon + \frac{\partial V}{\partial \theta} (\dot{\theta} - P_\theta) \quad (47)$$

where $\lambda_V = \min\{\lambda_{V_f}, \lambda_{V_p}, (2\lambda_{\min}(K_z)/k''_r)\}$ and $\varepsilon = w_f \varepsilon_f + \varepsilon_z$.

(b.) In addition, if $\Delta_i = 0, i = 1, 2$, then,

$$\dot{V} \leq -\lambda_V V + \tau_e^T \tilde{\theta}_{en} + \frac{\partial V}{\partial \theta} (\dot{\theta} - P_\theta) \quad (48)$$

where

$$\begin{aligned} \tau_e^T = & [\tau_f^T, \quad z_2^T Y_\beta, \quad z_2^T Y_\mu, \quad z_2^T Y_\vartheta] \\ \tilde{\theta}_e = & [\hat{\theta}^T, \quad \hat{\beta}^T, \quad \hat{\mu}^T, \quad \hat{\vartheta}^T]^T \end{aligned} \quad (49)$$

Proof: Noting (26), (32), and Property 2, we have

$$\begin{aligned} \dot{V} = & \dot{V}_f|_{u_f} + w_f \xi_f^T (x_{2,1} - u_f) + \dot{V}_p|_{u_p} \\ & + x_{\xi_p}^T P_{\xi_p} B_{\xi_p} (x_{2,2} - u_p) + z_2^T (M \dot{z}_2 + C z_2) \\ = & \dot{V}_f|_{u_f} + \dot{V}_p|_{u_p} \\ & + z_2^T [M(\dot{x}_2 - \dot{u}_{1d}) + C(x_2 - u_{1d}) + u'_r] \end{aligned} \quad (50)$$

Substituting the second equation of (11) into (50) and noting (41) and (43), we have

$$\begin{aligned} \dot{V} = & \dot{V}_f|_{u_f} + \dot{V}_p|_{u_p} + z_2^T \left\{ u_r - M z_v - C u_{1d} - G - D_t - L_r f_n \right. \\ & \left. - Y_3 - Y_\vartheta \vartheta + u'_r - M \begin{bmatrix} \frac{\partial u_f}{\partial \theta} \\ 0 \end{bmatrix} (\dot{\theta} - P_\theta) + \tilde{\Delta}_2 \right\} \end{aligned} \quad (51)$$

Noting that the only term in V that contains $\hat{\theta}$ is u_f in z_2 ,

$$\frac{\partial V}{\partial \theta} = -z_2^T M \begin{bmatrix} \frac{\partial u_f}{\partial \theta} \\ 0 \end{bmatrix} \quad (52)$$

Substituting the control law (44) into (51) and noting (6), (7), and (52),

$$\begin{aligned} \dot{V} = & \dot{V}_f|_{u_f} + \dot{V}_p|_{u_p} - z_2 K_z z_2 + z_2^T [u_{rs} + Y_\beta \hat{\beta}_\pi \\ & + Y_\mu \hat{\mu}_\pi + Y_\vartheta \hat{\vartheta}_\pi + \tilde{\Delta}_2] + \frac{\partial V}{\partial \theta} (\dot{\theta} - P_\theta) \end{aligned} \quad (53)$$

which leads to (47) because of (23), (36), and (45).

When $\Delta_i = 0$, from (15) and (46), $\tilde{\Delta}_i = 0$. Noting (24) and (36),

$$\begin{aligned} \dot{V} \leq & -\lambda_{V_f} V_f - \lambda_{V_p} V_p - z_2 K_z z_2 + \tau_f^T \tilde{\theta}_\pi + z_2^T u_{rs} + z_2^T Y_\beta \hat{\beta}_\pi \\ & + z_2^T Y_\mu \hat{\mu}_\pi + z_2^T Y_\vartheta \hat{\vartheta}_\pi + \frac{\partial V}{\partial \theta} (\dot{\theta} - P_\theta) \end{aligned} \quad (54)$$

which leads to (48) because of i of (45). \square

Remark 2. There are several ways to choose the robust control terms u_{rs} and u_{rs} to satisfy (22) and (45). Since u_{rs} is required to be continuous only, it can be any continuous approximation of the discontinuous term $-h_z(z_2/\|z_2\|)$ with an approximation error ε_z . $-h_z(z_2/\|z_2\|)$ is normally used in sliding mode control (SMC) where h_z is a bounding function satisfying

$$h_z \geq \|Y_\beta \hat{\beta}_\pi + Y_\mu \hat{\mu}_\pi + Y_\vartheta \hat{\vartheta}_\pi + \tilde{\Delta}_2\| \quad (55)$$

h_z exists since $\hat{\beta}_\pi, \hat{\vartheta}_\pi$, and $\hat{\mu}_\pi$ are bounded by some known constants because of the use of smooth projections. See [12, 23] for different approximation methods. Similarly, we can choose u_{fs} to be a differentiable continuous approximation of the discontinuous term $-h_f(\xi_f/\|\xi_f\|)$ where h_f satisfies

$$h_f(\epsilon, \xi_f, \bar{\theta}_\pi, t) \geq \|\tilde{\Delta}_1 + Y_\theta(\epsilon) \bar{\theta}_\pi + \frac{1}{2} \dot{K}_f \xi_f\| \quad (56)$$

\diamond

Lemma 4. If the initial values of the filtered motion and force trajectories are chosen as

$$\begin{aligned} f_{nr}(0) = & f_n(0), \quad \dot{f}_{nr}(0) = \dot{K}_f^{-1}(0) \dot{r}_f(0) \\ r_{pr}(0) = & r_p(0), \quad \dot{r}_{pr}(0) = \dot{r}_p(0) \end{aligned} \quad (57)$$

\diamond then, by setting $I_f(0) = 0, V(0) = 0$ and $z(0) = 0$. \triangle

Proof: It is obvious that $e_f(0) = 0$, $\xi_f(0) = 0$, $e_p(0) = 0$, $y_p(0) = 0$, $x_{\xi_p} = 0$, and $\xi_p(0) = 0$. From (20), $u_{fa}(0) = \hat{K}_f \dot{f}_{nr}(0)$ and $u_{fs}(0) = 0$. $z_2(0) = 0$ and $V(0) = 0$ are thus obvious. \square

Let the adaptation law be

$$\begin{aligned}\dot{\hat{\theta}} &= P_{\theta}, \quad P_{\theta} = -\Gamma_{\theta}[l_{\theta}(\hat{\theta}) + \tau_f] \\ \dot{\hat{\beta}} &= -\Gamma_{\beta}[l_{\beta}(\hat{\beta}) + Y_{\beta}^T z_2] \\ \dot{\hat{\mu}} &= -\Gamma_{\mu}[l_{\mu}(\hat{\mu}) + Y_{\mu}^T z_2] \\ \dot{\hat{\vartheta}} &= -\Gamma_{\vartheta}[l_{\vartheta}(\hat{\vartheta}) + Y_{\vartheta}^T z_2]\end{aligned}\quad (58)$$

where l_{θ} , l_{β} , l_{μ} , and l_{ϑ} are any bounded modification functions satisfying the following two conditions

$$\begin{aligned}i. \quad l_{\bullet}(\hat{\bullet}) &= 0 \quad \text{if } \hat{\bullet} \in \Omega_{\bullet} \\ ii. \quad \hat{\bullet}^T l_{\bullet}(\hat{\bullet}) &\geq 0 \quad \text{if } \hat{\bullet} \notin \Omega_{\bullet}\end{aligned}\quad (59)$$

in which \bullet represents θ , β , μ , or ϑ . For specific modification functions, see [12, 23]. Some examples suitable for this application are given in the following remark.

Remark 3. Note that $l_{\bullet}(\hat{\bullet}) = 0$ is a trivial solution of (59), which, in general, makes the resulting control law simple and easy to implement. The reason of introducing l_{\bullet} is to make the parameter adaptation process more robust since l_{\bullet} functions as a nonlinear damping in the parameter adaptation law (58). In this application, the adaptation law for $\hat{\beta}$, $\hat{\mu}$, and $\hat{\vartheta}$, the right hand side of (58), can be discontinuous since the resulting $\hat{\beta}$, $\hat{\mu}$, and $\hat{\vartheta}$ are still continuous and the control law (44) uses $\hat{\beta}$, $\hat{\mu}$, and $\hat{\vartheta}$ only. Thus, the same as in [12], we can use the popular discontinuous projection method [27] for l_{β} , l_{μ} , and l_{ϑ} . See [12] for the details.

For $\hat{\theta}$, since P_{θ} is also used in the control law (44), we have to use the continuous modification function l_{θ} . One simple solution is to use the idea of continuous projection method proposed in [28], which is simplified as follows. Let $W_{\theta} > 0$ be a weighting matrix such that Ω_{θ} is contained in the set $\Omega_{\theta'} = \{\theta: \|W_{\theta}(\theta - \theta_n)\| \leq 1\}$ for some known θ_n . $\forall y$, define the continuous projection of y as

$$\text{Proj}(\hat{\theta}, y) = \begin{cases} y & \text{if } \hat{\theta} \in \Omega_{\theta'} \\ y & \text{if } \hat{\theta} \notin \Omega_{\theta'} \text{ and } (\hat{\theta} - \theta_n)^T W_{\theta}^2 y \leq 0 \\ y - \frac{(\|W_{\theta}(\hat{\theta} - \theta_n)\|^2 - 1)(\hat{\theta} - \theta_n)^T W_{\theta}^2 y}{\varepsilon_{\theta'}(2 + \varepsilon_{\theta'})\|W_{\theta}^2(\hat{\theta} - \theta_n)\|^2} W_{\theta}^2(\hat{\theta} - \theta_n) & \text{if } \hat{\theta} \notin \Omega_{\theta'} \text{ and } (\hat{\theta} - \theta_n)^T W_{\theta}^2 y > 0 \end{cases}$$

where $\varepsilon_{\theta'}$ is any small positive number. Let the adaptation law for $\hat{\theta}$ be

$$\dot{\hat{\theta}} = \sigma_{\theta} \text{Proj}(\hat{\theta}, -\tau_f), \quad \hat{\theta}(0) \in \Omega_{\theta} \quad (61)$$

i.e., letting $\Gamma_{\theta} = \sigma_{\theta} I$ and $l_{\theta} = -\tau_f - \text{Proj}(\hat{\theta}, -\tau_f)$ in (58). Then, similar to [28], it can be proved that the adaptation law (61) guarantees that

$$\begin{aligned}i. \quad \hat{\theta} \in \Omega_{\theta'} &= \{p: \|W_{\theta}(p - \theta_n)\| \leq 1 + \varepsilon_{\theta'}\}, \quad \forall \tau_f \\ ii. \quad \hat{\theta}^T l_{\theta} &\geq 0, \quad \forall \tau_f\end{aligned}\quad (62)$$

Since $\Omega_{\theta'}$ is a known bounded set, we can restrict the smooth projection $\pi(\hat{\theta})$ to a class of smooth projections with the property that $\pi(\hat{\theta}) = \hat{\theta}$, $\forall \hat{\theta} \in \Omega_{\theta'}$. In other words, we actually do not use smooth projection in implementation in view of i of (62). It is thus easy to verify that (59) is satisfied and the continuous projection (61) is a valid continuous modification function. \diamond

Theorem 1. When the robot manipulator described by (4) moves on the stiff surfaces (1) with the interaction force (5), the following results hold if the control law (44) with the adaptation law (58) and the initial values (57) is applied:

(a) In general, the control input is bounded and e_p , z_p , e_f , and I_f exponentially converge to some balls whose size can be freely adjusted by controller parameters in a known form. Furthermore, V is bounded above by

$$V(t) \leq \frac{\varepsilon}{\lambda_V} [1 - \exp(-\lambda_V t)] \quad (63)$$

(b) When the system does not have uncertain nonlinearities, i.e., Φ_e and K_e are unknown but constant and $\Delta_2 = 0$ in (11), in addition to the results in a) of the theorem, asymptotic motion and force tracking control is achieved, i.e., $e_p \rightarrow 0$ and $e_f \rightarrow 0$ when $t \rightarrow \infty$. \triangle

Proof: In general, from (47), (58), and Lemma 4, (63) is true. Since the exponential converging rate λ_V and the bound of the final tracking error, $V(\infty) \leq (\varepsilon/\lambda_V)$, can be freely adjusted by the controller parameters ε_f , ε_p , D_2 , λ_{V_p} , and K_z in a known form (a) of the theorem is true.

Define

$$V_{\theta_e}(\tilde{\theta}_e) = \sum \frac{1}{\gamma_i} \int_0^{\tilde{\theta}_e} (\pi_i(\nu_i + \theta_{ei}) - \theta_{ei}) d\nu_i \quad (64)$$

where $\gamma_i > 0$. The same as in [29, 14], it can be proved that V_{θ_e} is a p.d. function w.r.t. $\tilde{\theta}_e$ and

$$\frac{\partial}{\partial \tilde{\theta}_e} V_{\theta_e}(\tilde{\theta}_e) = \tilde{\theta}_{e\pi}^T \Gamma_e^{-1} \quad (65)$$

where $\Gamma_e = \text{diag}\{\gamma_i\}$. Thus, we can choose a p.d. function as

$$V_a = V + V_{\theta_e} \quad (66)$$

In the absence of uncertain nonlinearities, $\Delta_i = 0$ and θ is unknown but constant. From (48), (58), (59), and (65),

$$\begin{aligned}\text{if } \hat{\theta} \in \Omega_{\theta'} \\ \hat{\theta} \notin \Omega_{\theta'} \text{ and } (\hat{\theta} - \theta_n)^T W_{\theta}^2 y \leq 0 \\ \hat{\theta} \notin \Omega_{\theta'} \text{ and } (\hat{\theta} - \theta_n)^T W_{\theta}^2 y > 0\end{aligned}\quad (60)$$

$$\begin{aligned}\dot{V}_a &\leq -\lambda_V V + \tau_e^T \tilde{\theta}_{e\pi} + \tilde{\theta}_{e\pi}^T \Gamma_e^{-1} \dot{\tilde{\theta}}_e \\ &\leq -\lambda_V V - \tilde{\theta}_{e\pi}^T l_{\theta}(\hat{\theta}) - \tilde{\beta}_{\pi}^T l_{\beta}(\hat{\beta}) - \tilde{\mu}_{\pi}^T l_{\mu}(\hat{\mu}) - \tilde{\vartheta}_{\pi}^T l_{\vartheta}(\hat{\vartheta}) \\ &\leq -\lambda_V V\end{aligned}\quad (67)$$

Thus, $V \in L_1$. It is easy to prove that V is uniformly continuous. By using Barbalat's lemma, V converges to zero and thus b of the theorem is true. \square

IV Simulation

A two DOF direct drive SCARA robot in the Cartesian space shown in Fig. 1 is used in the simulation. Dynamic equation of the robot can be found in [12] where the robot parameter set is $\beta = [p_1, p_2, p_3]^T$. Actual values of the robot parameters (with a payload of 10 kg) are $l_1 = 0.36$ m, $l_2 = 0.24$ m, $\beta = [5.1023, 0.7502, 1.03685]^T$, and $d = 0.35$ m. The exact value of β is assumed to be unknown with initial estimate $\hat{\beta}(0) = [1.8, 0.1, 0.1]^T$.

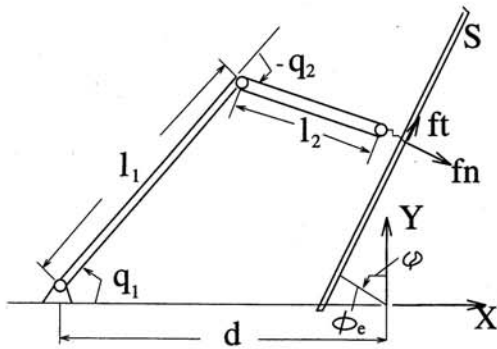

Fig. 1 Configuration of the robot

The robot is assumed in contact with a surface S , which rotates around the Z -axis as shown in Fig. 1. The surface S has a stiffness $k_e = 4000$ and a friction coefficient $\mu = 0.3$. k_e and μ are assumed to be unknown with initial estimates $\hat{k}_e = 500$ and $\hat{\mu} = 0$. The time-varying undeformed surface S is described by

$$-x \sin(\varphi(t)) + y \cos(\varphi(t)) = \Phi_e(t),$$

$$\varphi(t) = \frac{3}{8}\pi - \frac{1}{8}\pi \cos\left(\frac{1}{2}\pi t\right) \quad (68)$$

where the distance between S and Z -axis, Φ_e , is given by $\Phi_e(t) = 0.0025 \cos(w_e t)$ and w_e is unknown. Thus, the task space (2) can be defined as

$$r = [r_f, r_p]^T, \quad r_f = -x \sin(\varphi) + y \cos(\varphi),$$

$$r_p = x \cos(\varphi) + y \sin(\varphi) \quad (69)$$

The task space dynamic Eq. (1) can thus be obtained where F_r is given by (5) with

$$L_r = \begin{bmatrix} 1 \\ \mu \text{sign}(f_n) \text{sign}(\dot{r}_p) \end{bmatrix} \quad (70)$$

and $\bar{L}_r = 0$. f_μ and Y_μ can be obtained from (6). Let $\theta = K_f \in R$. Then, f_θ and Y_θ in (8) are 0 and ϵ respectively. Y_1 and Y_2 can be obtained from (40) and f_β and Y_β can be obtained from (7). Define ϑ as $\vartheta = [K_e \beta_1, K_e \beta_2, K_e \beta_3]^T$. Y_3 and Y_ϑ can be formed from (43) where $Y_3 = 0$.

Fast changing desired trajectories are used to test the performance, where $r_{pd} = 0.14(1 - \cos(2\pi t))$ and $f_{nd} = -40 + 20 \cos(2\pi t)$. Each of the filtered desired trajectories r_{pr} and f_{nr} is created on line by a critically damped second-order system with a corner frequency of 10 and initial conditions determined from (57). An integrator is used for the dynamic compensator, i.e., $A_p = 0, B_p = 1, D_p = 20, C_p = 100$. Then the resulting motion sliding mode is critically damped with a corner frequency of 10. $\beta_{\min} = [1.0, 0.05, 0.05]^T, \beta_{\max} = [6.0, 0.8, 1.2]^T, \theta_{\min} = 0.0002, \theta_{\max} = 0.004, \mu_{\min} = 0, \mu_{\max} = 0.4, \vartheta_{\min} = [250, 12.5, 12.5]^T$, and $\vartheta_{\max} = [30000, 4000, 6000]^T$ are used to define the sets $\Omega_\beta, \Omega_{l_\theta}, \Omega_\mu$, and Ω_ϑ for allowable parametric uncertainties. As explained in Remark 3, we use the discontinuous projection for l_β, l_μ , and l_ϑ , and the continuous projection (61) for l_θ . Parameters in (61) are $\theta_n = 0.0021, W_\theta = 1/0.0019$, and $\epsilon_{\vartheta'} = 0.05$. Robust control terms u_{fs} and u_{rs} are chosen according to Remark 2, in which a smooth approximation in [14] is used for u_{fs} , i.e., $u_{fs} = -h_f \tanh(0.2785 h_f \xi_f / \epsilon_f)$, and a continuous approximation in [12] (method 2) is used for u_{rs} with a diagonal feedback gain matrix K_{rs} for z_2 within a boundary layer thickness of $\phi_z / (h_z + 1)$. The control input is calculated from (44) with a sampling rate of $\Delta T = 2$ ms. Controller parameters used in the simulation are $D_1 = 10, D_2 = 0.01, w_f = 0.5, \epsilon_f = 16.7, \dot{\vartheta}(0) = [900, 50, 50]^T, K_z = \text{diag}\{200, 400\}, Q_{\xi_p} = 5000, \phi_z = 1500$ and $K_{rs} = \text{diag}\{600, 600\}$. Parameters used for

adaptation rate are $\Gamma_\theta = 0.00001, \Gamma_\beta = \text{diag}\{4, 0.2, 0.2\}, \Gamma_\mu = 0.8$, and $\Gamma_\vartheta = \text{diag}\{20000000, 2000000, 2000000\}$.

The following three controllers are run for comparison:

ARC: The ARC law as described in the above.

DRC: Same control law as in ARC but without parameter adaptation. In this case, the resulting control law becomes a deterministic robust control law [15], which can achieve the results stated in a) of Theorem 1.

AC: The control law obtained by letting $u_{fs} = 0, u_{rs} = 0, \pi(\bullet) = \bullet$, and $l_\bullet(\bullet) = 0$ in ARC, i.e., no robust control terms and no projection and modification for parameter adaptation laws. In this case, the resulting control law becomes an adaptive control law [15], which can achieve the results stated in (b) of Theorem 1.

To test nominal performance of each controller, simulations are first run for parametric uncertainties only ($w_e = 0$), i.e., conditions in (b) of Theorem 1. The filtered desired force trajectory f_{nr} converges to the desired force trajectory f_{nd} quickly without overshoot due to the use of trajectory initialization. The filtered desired motion trajectory r_{pr} is the same as the desired motion trajectory r_{pd} in this case since $r_{pr}(0) = r_{pd}(0)$. As shown in Fig. 2 and Fig. 3, all three controllers have good motion and force tracking ability, which avoids the loss of contact. ARC and AC have a better final tracking accuracy than DRC since some of the estimated parameters approach their true values. ARC also has a better transient response than AC. Control inputs for all three controllers do not exhibit chattering.

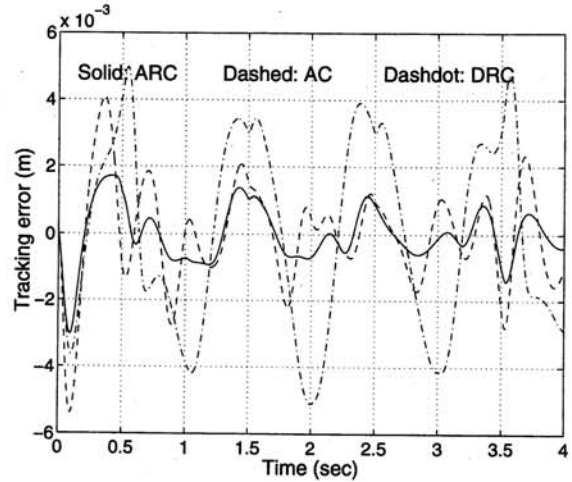

Fig. 2 Motion tracking errors in the presence of parametric uncertainties

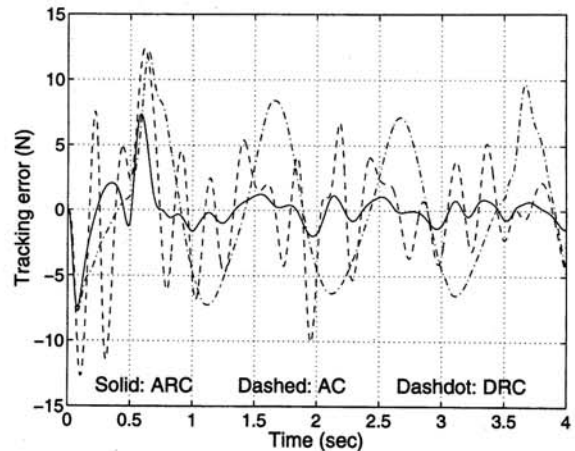

Fig. 3 Force tracking errors in the presence of parametric uncertainties

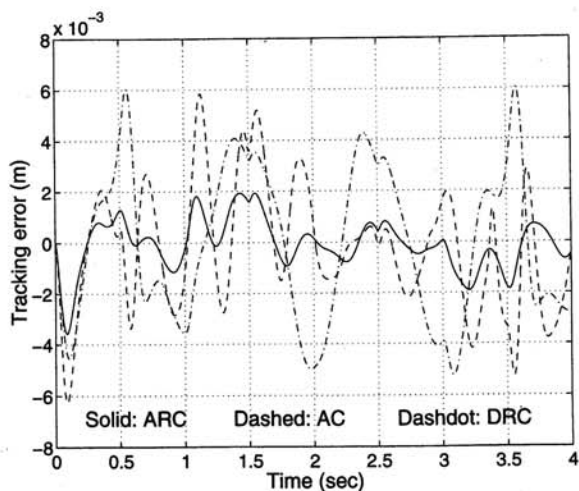

Fig. 4 Motion tracking errors in the presence of parametric uncertainties and large disturbances

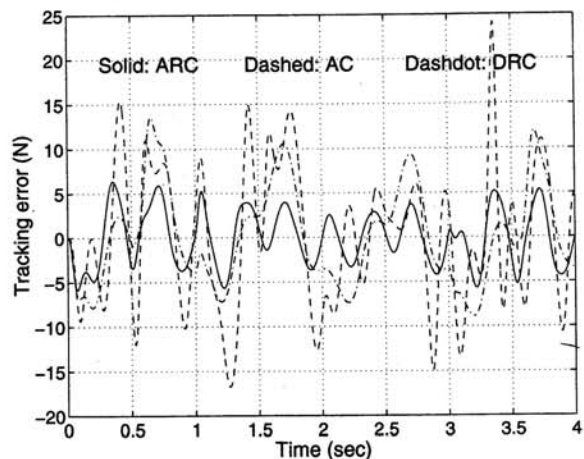

Fig. 5 Force tracking errors in the presence of parametric uncertainties and large disturbances

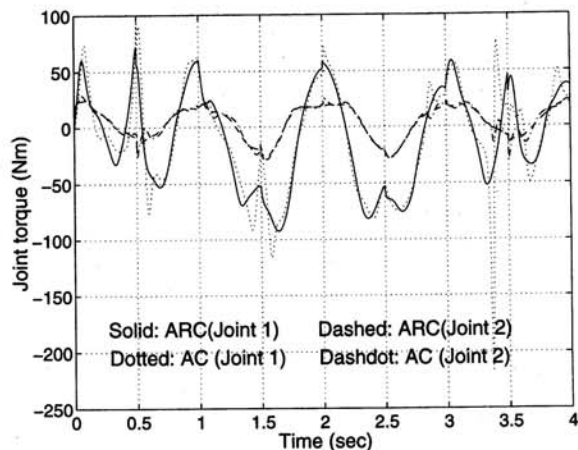

Fig. 6 Control inputs in the presence of parametric uncertainties and large disturbances

To test performance robustness, simulation are then run in the presence of time-varying $\phi_e(t)$ and very large disturbances, i.e., $w_e = 6\pi$ and $\hat{f} = (-1)^{\text{round}(t)}[30, 30]^T$ in (4). As shown in Fig. 4 and Fig. 5, ARC still achieves the best motion and force tracking results. AC has the worst tracking performance and needs a very large control effort sometimes (Fig. 6) since its parameter estimates are unbearably wrong

due to the appearance of disturbances. Again, control inputs of the proposed ARC do not exhibit chattering. All these results illustrate the advantages of the proposed ARC motion and force controller.

V Conclusions

In this paper, adaptive robust control is applied to solve the motion and force tracking control of robot manipulators in contact with unknown stiffness environment. The system is subjected to both parametric uncertainties and uncertain nonlinearities coming from various sources. The guaranteed transient performance of the resulting controller alleviates the problem of loss of contact and makes the approach attractive to implementation. Asymptotic motion and force tracking is obtained in the presence of parametric uncertainties without resorting to discontinuous control law or infinite feedback gains. Simulation results verify the advantages of the proposed ARC motion and force controller.

References

- 1 N. Hogan, "Impedance Control: An Approach to Manipulation: Part I, Part II, Part III," *ASME JOURNAL OF DYNAMIC SYSTEMS, MEASUREMENT, AND CONTROL*, Vol. 107, pp. 1-24, 1985.
- 2 B. Yao, S. P. Chan, and D. Wang, "A Unified Approach to Variable Structure Control of Robot Manipulators," *Proc. of American Control Conference*, pp. 1282-1286, 1992. Revised version "Unified Formulation of Variable Structure Control Schemes to Robot Manipulators", *IEEE Trans. on Automatic Control*, Vol. 39, No. 2, pp. 371-376, 1994.
- 3 N. H. McClamroch and D. Wang, "Feedback Stabilization and Tracking of Constrained Robots," *IEEE Trans. on Automatic and Control*, Vol. 33, No. 5, pp. 419-426, 1988.
- 4 B. Yao and M. Tomizuka, "Adaptive Control of Robot Manipulators in Constrained Motion—Controller Design," *ASME JOURNAL OF DYNAMIC SYSTEMS, MEASUREMENT, AND CONTROL*, Vol. 117, No. 3, pp. 320-328, 1995.
- 5 S. Arimoto, T. Naniwa, and Y. H. Liu, "Model-Based Adaptive Hybrid Control for Manipulators with Geometric Endpoint Constraint," *Advanced Robotics*, Vol. 9, No. 1, pp. 67-80, 1995.
- 6 J. Hu, M. D. Queiroz, T. Burg, and D. Dawson, "Adaptive Position/Force Control of Robot Manipulators Without Velocity Measurements," *Proc. of IEEE Conf. on Robotics and Automation*, pp. 887-892, 1995.
- 7 R. R. Y. Zhen and A. A. Goldenberg, "An Adaptive Approach to Constrained Robot Motion Control," *Proc. IEEE Conf. on Robotics and Automation*, pp. 1833-1838, 1995.
- 8 O. Khatib, "A Unified Approach for Motion and Force Control of Robot Manipulators: The Operation Space Formulation," *IEEE J. Robotics and Automation*, Vol. 3, No. 1, pp. 43-53, 1987.
- 9 B. Yao, S. P. Chan, and D. Wang, "Variable Structure Adaptive Motion and Force Control of Robot Manipulators," *Automatica*, Vol. 30, No. 9, pp. 1473-1477, 1994.
- 10 R. Carelli, R. Kelly, and R. Ortega, "Adaptive Force Control of Robot Manipulators," *Int. J. Control*, Vol. 52, No. 1, pp. 37-54, 1990.
- 11 B. Yao and M. Tomizuka, "Robust Adaptive Motion and Force Control of Robot Manipulators in Unknown Stiffness Environment," *Proc. of IEEE Conf. on Decision and Control*, pp. 142-147, 1993.
- 12 B. Yao and M. Tomizuka, "Smooth Robust Adaptive Sliding Mode Control of Robot Manipulators with Guaranteed Transient Performance," *Proc. of American Control Conference*, 1994. The full paper appeared in *ASME JOURNAL OF DYNAMIC SYSTEMS, MEASUREMENT, AND CONTROL*, Vol. 118, No. 4, pp. 764-775, 1996.
- 13 B. Yao and M. Tomizuka, "Comparative Experiments of Robust and Adaptive Control with New Robust Adaptive Controllers for Robot Manipulators," *Proc. of IEEE Conf. on Decision and Control*, pp. 1290-1295, 1994.
- 14 B. Yao and M. Tomizuka, "Adaptive Robust Control of SISO Nonlinear Systems in a Semi-Strict Feedback Form," *Automatica*, Vol. 33, No. 5, pp. 893-900, 1997. (Part of the paper appeared in *Proc. of 1995 American Control Conference*, pp. 2500-2505).
- 15 B. Yao and M. Tomizuka, "Adaptive Robust Control of MIMO Nonlinear Systems," submitted to *Automatica*, 1997 (revised). Parts of the paper were presented in the *IEEE Conf. on Decision and Control*, pp. 2346-2351, 1995, and the *IFAC World Congress*, Vol. F, pp. 335-340, 1996.
- 16 V. I. Utkin, *Sliding Modes in Control Optimization*, Springer Verlag, 1992.
- 17 M. J. Corless and G. Leitmann, "Continuous State Feedback Guaranteeing Uniform Ultimate Boundedness for Uncertain Dynamic Systems," *IEEE Trans. on Automatic Control*, Vol. 26, No. 10, pp. 1139-1144, 1981.
- 18 N. Sadegh and R. Horowitz, "Stability and Robustness Analysis of a Class of Adaptive Controllers for Robot Manipulators," *Int. J. Robotic Research*, Vol. 9, No. 3, pp. 74-92, 1990.
- 19 J. J. E. Slotine and W. Li, "Adaptive Manipulator Control: A Case Study," *IEEE Trans. on Automatic Control*, Vol. 33, No. 11, pp. 995-1003, 1988.

20 J. T. Wen and D. S. Bayard, "New Class of Control Laws for Robotic Manipulators, Part 1: Non-Adaptive Case, Part 2: Adaptive Case," *Int. J. of Control*, Vol. 47, No. 5, pp. 1361-1406, 1988.

21 M. Krstic, I. Kanellakopoulos, and P. V. Kokotovic, *Nonlinear and Adaptive Control Design*, Wiley, New York, 1995.

22 Z. Qu, D. M. Dawson, and J. F. Dorsey, "Exponentially Stable Trajectory Following of Robotic Manipulators Under a Class of Adaptive Controls," *Automatica*, Vol. 28, No. 3, pp. 579-586, 1992.

23 B. Yao, "Adaptive Robust Control of Nonlinear Systems with Application to Control of Mechanical Systems," PhD thesis, Mechanical Engineering Department, University of California at Berkeley, Berkeley, Jan. 1996.

24 B. Yao, W. B. Gao, and S. P. Chan, "Robust Constrained Motion Control of Multi-Arm Robots Holding a Common Object," *Proc. IEEE Conf. IECON'90*, pp. 232-237, 1990.

25 T. H. Chang and Y. Hurmuzlu, "Sliding Control Without Reaching Phase and its Application to Bipedal Locomotion," *ASME JOURNAL OF DYNAMIC SYSTEMS, MEASUREMENT, AND CONTROL*, Vol. 115, No. 3, pp. 447-455, 1993.

26 R. Volpe and P. Khosla, "An Experimental Evaluation and Comparison of Explicit Force Control Strategies for Robotic Manipulators," *Proc. IEEE Conf. on Robotics and Automation*, pp. 1387-1393, 1992.

27 S. Sastry and M. Bodson, *Adaptive Control: Stability, Convergence and Robustness*, Prentice Hall, Englewood Cliffs, NJ 1989.

28 J. B. Pomet and L. Praly, "Adaptive Nonlinear Regulation: Estimation From the Lyapunov Equation," *IEEE Trans. on Automatic Control*, Vol. 37, pp. 729-740, 1992.

29 A. R. Teel, "Adaptive Tracking with Robust Stability," *Proc. 32nd Conf. on Decision and Control*, pp. 570-575, 1993.