

# Hypersonic Wind Tunnels



Arnold Engineering Development Center  
An Air Force Materiel Command Test Center

## AEDC: One of Two AFMC Test Centers

The U. S. Air Force's Arnold Engineering Development Center (AEDC), located in southern middle Tennessee and Silver Springs, Maryland, is a Major Range and Test Facility Base that performs Research, Development, Test and Evaluation programs for the Air Force, DoD, other government agencies and industry. Using ground test facilities, AEDC supports propulsion, aerodynamic, reentry, trans-atmospheric and space-flight systems testing.

## Hypersonic Wind Tunnels

The mission of the AEDC Hypersonic Wind Tunnel staff is to provide customers with complete testing and analysis services. AEDC integrates world-class test facilities with state-of-the-art analysis techniques to accomplish this mission. The Von Karman Gas Dynamics Facility (VKF) in Tennessee is comprised of a supersonic wind tunnel (Tunnel A) and two hypersonic wind tunnels (Tunnels B and C). AEDC's Hypersonic Wind Tunnel 9 is located at the White Oak Facility in Maryland.



*The Von Karman  
Gas Dynamics  
Facility in  
Tennessee*

*Hypersonic Wind  
Tunnel 9 in White  
Oak, Maryland*



## Supersonic Wind Tunnel A

Tunnel A is a variable density, continuous-flow wind tunnel with an automatically driven flexible-plate nozzle capable of being operated at Mach numbers from 1.5 to 5.5 at maximum stagnation pressures from 29 to 200 psia, respectively, and stagnation temperatures up to 750 deg R. The tunnel is equipped with a model injection system which allows removal of the model from the test section while the tunnel remains in operation. The test section area is 40 inches square.



## Test Operations

- Computerized control of tunnel conditions, model attitude, model internal servo-motors, and data acquisition
- Testing using either move-pause or continuous-motion data acquisition techniques
- Typical continuous-motion data is acquired while moving the test article at 1 degree per second.

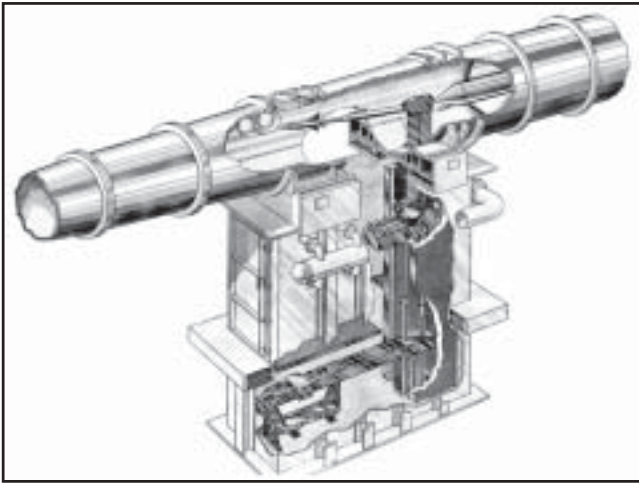

## Hypersonic Wind Tunnels B and C

Tunnels B and C are the largest, 50-inch diameter test section, operational continuous flow hypersonic tunnels in the U.S. Axisymmetric fixed geometry nozzles provide Mach 4, 6, 8, and 10 conditions with maximum stagnation pressure ranging from 300 to 2000 psia and maximum stagnation temperatures ranging from 1350 to 2260 deg R. Both tunnels are provided with model injection systems which allow removal of the model from the test section while the tunnel remains in operation. The Mach 4 Tunnel C configuration can match flight conditions at 56,000 ft altitude.

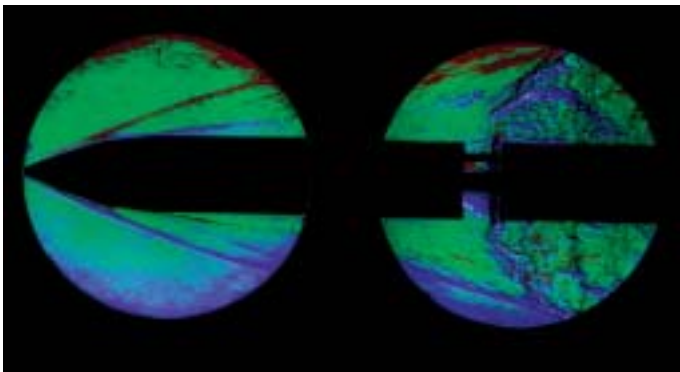

Captive Stage Separation



## Hypersonic Wind Tunnel 9

Tunnel 9 provides aerodynamic simulation at Mach numbers 7, 8, 10, 14, and 16.5 with stagnation pressures up to 1900 atmospheres and stagnation temperatures up to 3650 deg R. The test sections are five foot in diameter. The intermittent operation of up to 15 seconds allows for an angle-of-attack sweep or flow field survey during the flow period.

### Shroud Separation

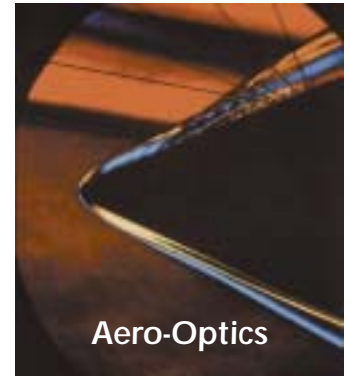
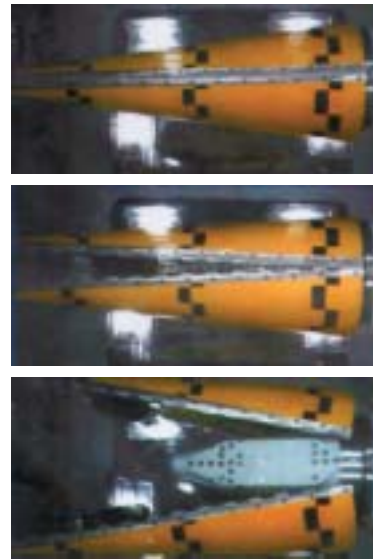

Aero-Optics

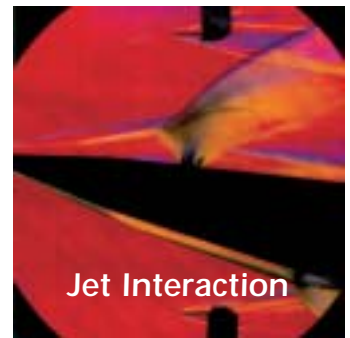

Jet Interaction



## Hypersonics Tunnels Performance Map

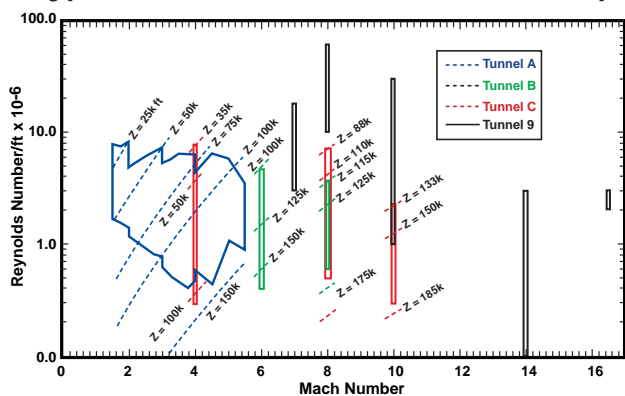

## Test Capabilities

- Aerodynamic Performance
- Static Stability
- Pressure Loads
- Jet Interaction
- Range and Safety
- Captive Trajectory Store Separation
- Vehicle Staging
- Flutter and Aero-elastic
- Flow-Field Surveys
- Inlet Performance
- Inlet Drag
- Acoustic Testing
- Heat Transfer



*Planned State-of-the-Art Control Room for VKF*

- Material Sampling
- Thermal Mapping
- Aero-Optics
- Shroud Separation

## Test Support System

- Internal Strain-Gage Balances
- Steady-state and Dynamic Pressure Measurement Systems
- High Pressure Air System capable of up to 3,000 psia supply pressure and mass flow rates up to 90 lbm/sec
- Flow Visualization Systems: Schlieren/Shadowgraph, Laser Sheet, Oil Flow,
- High Speed Photography

## Data Acquisition Systems

The VKF data acquisition systems are completely automated and consists of:

**Static Data Acquisition System** - Channels: 48 Force Balance (constant voltage/current) for Strain Gage Transducers (force, pressure, acceleration, position, etc.). Phase Matched Filters and Simultaneous Sampling Enable Continuous Sweep Test Modes.

**Pressure Scanning System** - Channels: Up to 768 Electronically Scanned Pressures (ESP) in Ranges from  $\pm 1$  PSID to 100 PSID.

**Temperature Scanning System** - Channels: Up to 896 Electronically Scanned Thermocouple and Heat-Flux Gages (Coaxial, Schmidt-Boelter, Gardon) in any combination.

## Computational and Analysis Support

AEDC possesses a broad range of analysis capabilities to support test and evaluation needs. Computational experts can calculate aerodynamic loads and flight simulations prior to test conduct using empirical, analytical, and/or viscouscomputational fluid dynamics methodologies. Data predictions are typically used to identify test matrix variables, variable ranges, instrumentation requirements, or support system interference. Analysts familiar with the predictions are available to asses test data in real-time to provide an independent review of the results. As the test progresses, analytical tools

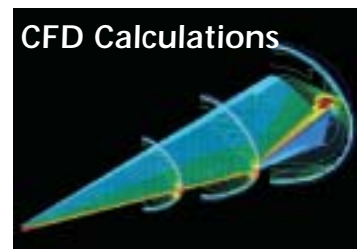

**CFD Calculations**



**Experimental Measurements**

allow enhanced insights from data simulations and resolution of data anomalies. Following the test, a variety of performance assessments, flow visualizations, and mathematic modeling are used to expand the test database.

## Other AEDC Wind Tunnel Facilities Available

PWT Tunnel 16T	Mach .06–1.6
PWT Tunnel 16S	Mach 1.5–4.5
PWT Tunnel 4T	Mach 0.05–2.0

### Excellent Flow Quality

- Uniform Flow Properties
- Low Free-Stream Turbulence
- Low Free-Stream Contamination
- Low Mach Number Uncertainty

### Test Confidentiality

- Facility designed to meet the strictest security requirements.
- Experienced with foreign countries and commercial interest.



Stage Separation Effects

For More Information, Contact:

**AEDC/DOF**

676 Second Street  
Arnold AFB TN  
37389-4000

(931) 454-7721  
DSN 340-7721  
[www.arnold.af.mil](http://www.arnold.af.mil)