

# A DUAL MODE MICROBUBBLE PRESSURE AND FLOW SENSOR

Lawrence Yu and Ellis Meng

University of Southern California, Los Angeles, USA

## ABSTRACT

We present the first microbubble ( $\mu\text{B}$ ) based dual mode sensor for static pressure and liquid flow. The transducer harnesses the inverse pressure-volume relation and high precision electrochemical impedance measurement (2% RSD) to monitor size of electrolytically generated  $\mu\text{Bs}$ . By altering sensor orientation, static pressure measurement (0-20 mmHg) or flow rate was transduced (0-1000  $\mu\text{L}/\text{min}$ ). The design targets chronic *in vivo* monitoring applications and therefore incorporates the following features: non-hermetic packaging, absence of moving parts, low power consumption ( $<5 \mu\text{W}$ ), and biocompatible construction (Parylene and Pt).

## INTRODUCTION

Implantable transducers enable around the clock monitoring of localized *in vivo* pressure and fluid flow, which are useful indicators of patient health or disease progression. Sensors may be implanted alongside coronary stents or hydrocephalus shunts and provide accurate, noninvasive monitoring through telemetry. A microfabricated pressure sensor would typically comprise a vacuum cavity sealed with a thin, flexible membrane that deflects upon application of external pressure. Two (or more) pressure sensors may be used in conjunction to infer flow information on the basis of Bernoulli's principle. However, *in vivo* differential pressure flow metering is challenged by the body's corrosive environment and the concomitant compromises in performance from hermetic sealing of the sensing elements [1]. To address these issues, pressure transduction using microbubbles was investigated with an open package device in direct contact with the electrolyte, but its use was limited to static conditions without flow [2]. This work improves pressure measurement resolution ( $5\times$  increase), further elucidates  $\mu\text{B}$  nucleation parameters necessary for pressure transduction within a flowing liquid, and introduces a two-port structure for measuring pressure differential (Fig. 1, 2). This marks the first demonstration of  $\mu\text{Bs}$  as pressure transducers for measurement of liquid flow and for dual mode sensing of both pressure and flow.

## DESIGN

The microbubble pressure transducer ( $\mu\text{BPT}$ ) utilizes a pair of platinum electrodes in an open Parylene C microchamber to first electrolytically generate a microbubble and then subsequently monitor its size and dissolution rate through the use of electrochemical impedance measurement (Fig. 1). Parylene (USP class VI polymer and inert) is highly biocompatible [3], serves as an excellent electrical insulator, and possesses great mechanical strength [4].

A confinement chamber is necessary to create a localized environment for the saturation of electrolytically generated gas. The ability to isolate the  $\mu\text{B}$  and control the environmental conditions allows for consistent

electrochemical measurements. At the same time, an open connection must be maintained to transduce pressure from the surrounding liquid environment to the confined  $\mu\text{B}$ .

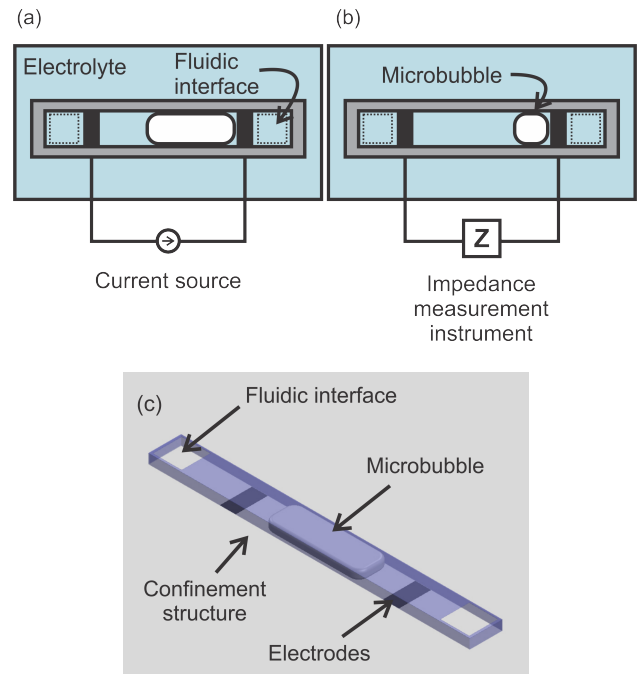

Figure 1: Cartoon of device operation, illustrating top down view of Parylene microstructure filled in electrolyte. (a) Nucleation of microbubble via electrolysis. (b) Impedance measurement of microbubble during dissolution. (c) 3D rendering of device, illustrating confinement of microbubble.

Impedance based transduction of pressure using a fluid filled sensor was first described by Ateya et al. through the use of electrolytic bubbles formed in silicon microchannels encapsulated in polydimethylsiloxane (PDMS) [5]. However, the device was limited to a rigid substrate with bulky fluidic interconnects and not suitable for *in vivo* implantation. The open-sensor design and all Parylene construction of this approach simplifies implementation and obviates requirements of hermeticity, greatly reducing the footprint. To our knowledge, this approach is the first application of such a sensing modality to microfabricated polymer-based transducers.

## Transduction Principle

In order to perform a pressure measurement, first a  $\mu\text{B}$  is formed via electrolysis (Fig. 1). The electrically insulating bubble now resides in the measurement channel region and is available for pressure transduction. A low power, high frequency alternating current applied across the EI measurement electrodes permits monitoring of the volumetric conductive path [6] and is measured as the electrochemical impedance,  $Z$ :

$$|Z|_{f \geq 10 \text{kHz}} \approx R_s = \frac{\rho \ell}{S_{Tot}} \quad (1)$$

where  $R_s$  is solution resistance,  $\rho$  is conductivity of electrolyte,  $\ell$  is the length of the fluid capillary formed by a  $\mu\text{B}$  residing in the microchannel, and  $S_{Tot}$  is the total cross sectional area occupied by the fluid capillaries [5]. External pressure of the liquid media is transferred through the interface ports, which directly influences bubble size as described by the Young-Laplace equation [7] and Boyle's law.

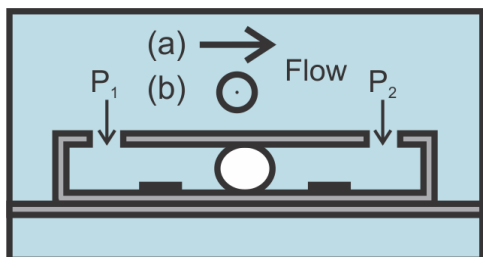

Figure 2: Cross section profile of device containing a trapped microbubble, with fluidic interfaces oriented (a) in line with and (b) normal to direction of liquid flow. Pressure differential due to flow is captured as difference in pressure applied through ports  $P_1$  and  $P_2$ .

The Venturi effect harnesses Bernoulli's principle, which describes the pressure differential that accompanies a change in fluid flow speed. By placing the fluidic interface ports parallel to the direction of flow (Fig. 2a), the confined bubble will experience this pressure differential which is a direct measure of flow rate. When the device is oriented such that the ports are perpendicular (Fig. 2b) to the flow, the bubble experiences no pressure differential due to flow but instead transduces the static pressure. Thus, the sensor may be operated in two different modes by changing the orientation of the device with respect to the direction of liquid flow.

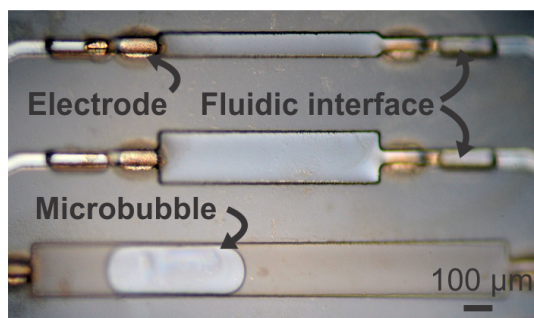

Figure 3: Micrograph of sensors soaked and filled with electrolyte. A variety of microchannel dimensions were utilized to enable testing of various electrolyte and flow parameters.

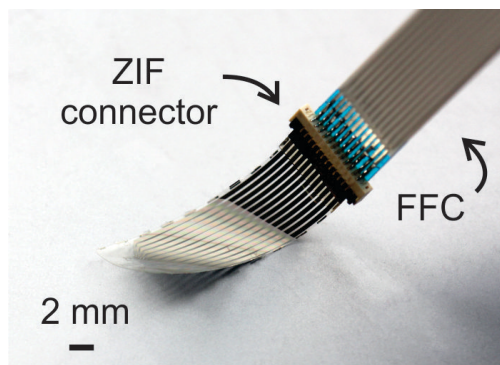

Figure 4: Photograph of microfabricated Parylene C device attached to flat flexible cable (FFC) via zero insertion force (ZIF) connector; connection scheme provides robust and reversible electrical contact.

## METHODS

### Fabrication

The devices (Fig. 3) were fabricated using surface micromachining techniques on a polymer substrate with thin film electrodes, a process based on previously reported techniques [2]. Platinum was e-beam deposited (2000 Å thick) and patterned on a Parylene coated (12  $\mu\text{m}$  thick) silicon wafer. Following deposition of a 10  $\mu\text{m}$  Parylene insulation layer, sacrificial photoresist was patterned to establish the microchannel. A final 4  $\mu\text{m}$  thick layer of Parylene was used to enclose the microchannel, and access ports were etched using switched-chemistry oxygen plasma etching process in a deep reactive ion etching (DRIE) tool [8]. The entire fabrication process was performed at relatively low temperatures (<90°C) to prevent thermal degradation of Parylene.

Devices were released in an acetone bath, and an electrical connection was established with a ZIF connector (Fig. 4) using previously reported methods [9]. The microchannel was first soaked in isopropyl alcohol to facilitate filling with 1 $\times$  PBS (phosphate buffered saline), an electrolyte that simulates *in vivo* conditions.

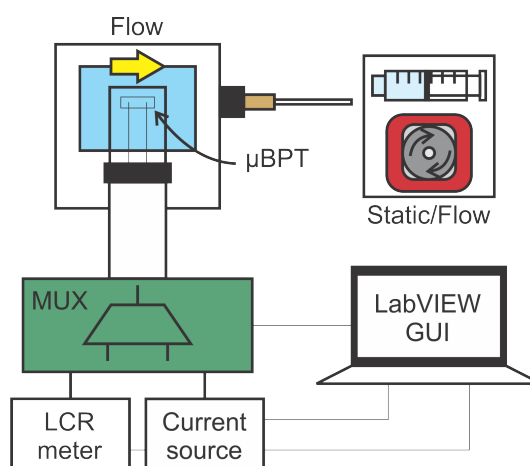

Figure 5: Schematic overview of test setup, illustrating electrical and fluidic connections.

### Experimental Setup

The  $\mu\text{B}$  transducer was housed within a custom acrylic test fixture, oriented parallel and normal to applied flow. A peristaltic pump (Watson-Marlow, Wilmington, MA) was

connected to the flow chamber (3 mm x 2 mm x 10 mm) and electrical connections were routed to custom multiplexing circuitry controlled via LabVIEW (Fig. 5).

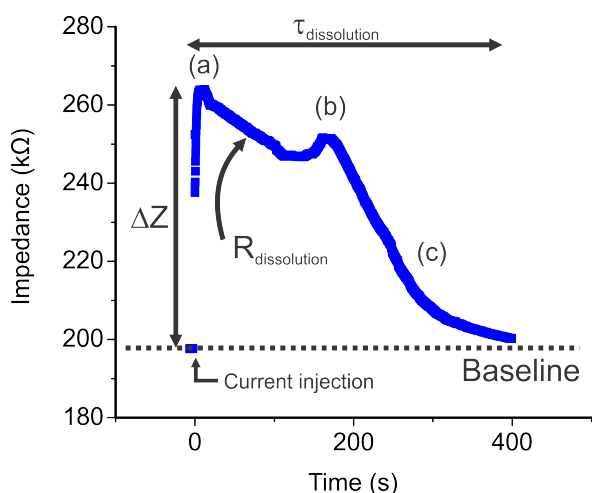

Figure 6: Representative impedance measurement of electrolytically generated microbubble, with indicators for parameters of interest. (a) Impedance of microbubble immediately following electrolysis. (b) Microbubble begins detachment from microchannel. (c) Microbubble rapidly recombines to fluid in presence of platinum electrode.

Electrochemical impedance spectroscopy (EIS) results indicated that 10 kHz was the optimum measurement frequency (minimum system phase) for maximizing the solution resistance component of the impedance response. Microbubbles were electrolytically generated in 1× PBS under conditions of 1-4  $\mu\text{A}$  for 2-5 s. Prior to and following current injection, impedance measurements were taken (Fig. 6) with a precision LCR meter (Agilent E4980A).

## RESULTS AND DISCUSSION

To maintain consistency between bubble nucleation events, the local electrolyte environment was saturated with dissolved gas by repeatedly injecting current to induce electrolysis. Current injections were repeated and impedance measurements were taken until  $\tau_{\text{dissolution}}$  was consistent to within 10% (Fig. 7). This priming process takes  $\sim 50$  minutes and lasts for  $\sim 3$  hours. The  $\Delta Z$  and  $\tau_{\text{dissolution}}$  (as illustrated in Fig. 6) from a primed environment impedance response curve (i.e. the 5th to 10th current injections in Fig. 7) were then analyzed for pressure transduction. Notably, the size of the nucleated bubble remained consistent ( $\sim 1\%$  RSD) while attempting to saturate the local dissolved gas environment, as seen in the low variance of  $\Delta Z$  (mean = 37.9 k $\Omega$ , standard deviation 574.6  $\Omega$ , n = 10).

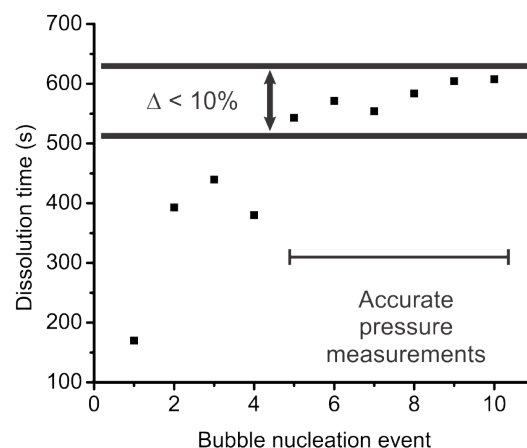

Figure 7: Tracking of dissolution time ( $\tau_{\text{dissolution}}$ ) for repeated bubble nucleation events. Once stabilized, the local electrolyte environment was saturated with dissolved gas and repeatable impedance measurements were realized.

For a given constant pressure environment and electrolysis parameters, impedance tracking of microbubble size during dissolution was performed. The  $\Delta Z$  metric (Fig. 6) was observed to have an inversely proportional relationship ( $\Delta Z = 60496 + (1.23 \times 10^6)/(\text{pressure (mmHg)} + 148.85)$ ,  $R^2 = 0.999$ ) to a randomly applied pressure (Fig. 8), suggesting that the impedance measurement is a direct measurement of the bubble volume relationship as described by the Young-Laplace equation and Boyle's law. The possibility of absolute pressure monitoring is promising with further calibration of saturation conditions.

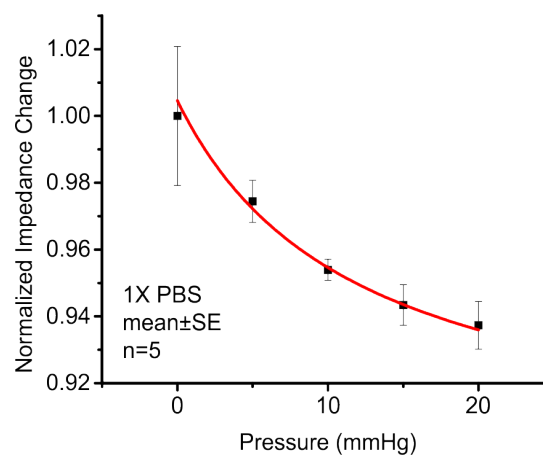

Figure 8: Normalized impedance change ( $\Delta Z$ ) is directly correlated to bubble size and confirms the Boyle's law pressure-volume relation.

Dissolution rate was also shown to have a correlation with pressure (Fig. 9). The observed relation was approximately linear (dissolution rate =  $100.70 + 0.67 \times \text{pressure (mmHg)}$ ,  $R^2 = 0.998$ ), as confirmed by Henry's law and the Epstein-Plesset equation [10]. Provided that the electrochemical measurement is taken when the environment properly primed, this metric provides a method to check the  $\Delta Z$  measurement on the same nucleated microbubble.

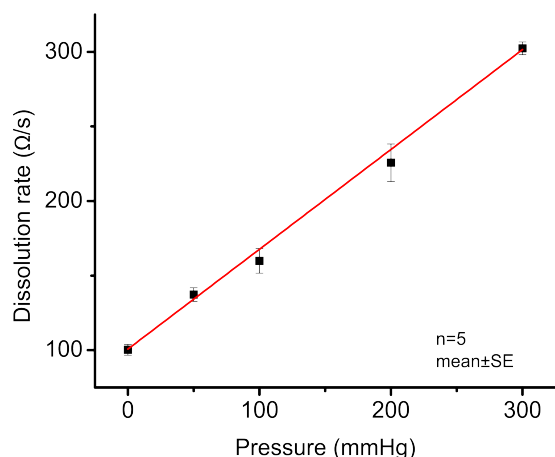

Figure 9: Dissolution rate ( $R_{dissolution}$  in Fig. 6) was found to be linearly related to hydrostatic pressure.

Measurements under liquid flow for the device oriented parallel to flow are presented in Fig. 10 and pressure was found to increase with increased flow, as described by Bernoulli's principle ( $R^2 = 0.92$ ). When oriented normal to direction of flow, flow sensing was negligible and only static pressure was measured. Switching between pressure and flow sensing can be achieved by changing sensor orientation with respect to direction of liquid flow.

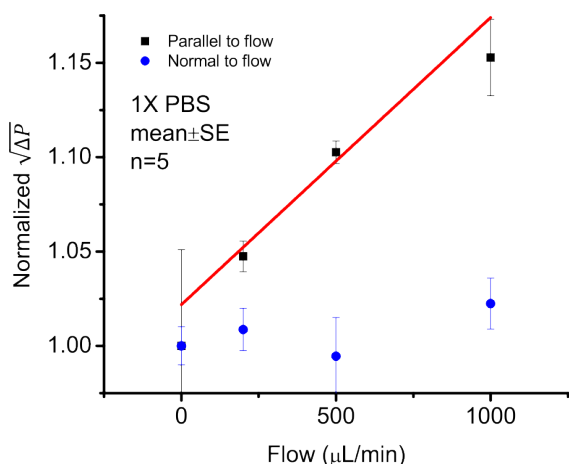

Figure 10: Differential pressure-flow relationship. With sensor oriented normal to flow, measured pressure is negligible. When sensor ports are oriented parallel to flow, measured pressure differential confirms square root relationship as described by Bernoulli's principle.

## CONCLUSION

A unique sensing mechanism for hydrostatic pressure measurement and liquid flow utilizing impedance based measurements of electrolytically generated microbubbles was developed and demonstrated. With the exceptional biocompatibility characteristics of the open-to-liquid packaging, this robust sensing mechanism can be used reliably for chronic *in vivo* measurements. Additional sensor characterization is planned and performance will be assessed in a clinical setting to achieve first-in-human demonstration.

## ACKNOWLEDGEMENT

This work was funded by the NSF under award number ECCS-1231994 and EFRI-1332394. The authors would like to thank Mr. J. Nishida, Mr. A. Jibodu, and the members of the USC Biomedical Microsystems Laboratory for their assistance.

## REFERENCES

- [1] L. Bowman and J. D. Meindl, "The packaging of implantable integrated sensors," *Biomedical Engineering, IEEE Transactions on*, pp. 248-255, 1986.
- [2] C. A. Gutierrez and E. Meng, "A subnanowatt microbubble pressure sensor based on electrochemical impedance transduction in a flexible all-parylene package," in *24th IEEE International Conference on Micro Electro Mechanical Systems, MEMS 2011, January 23, 2011 - January 27, 2011*, Cancun, Mexico, 2011, pp. 549-552.
- [3] T. Y. Chang, V. G. Yadav, S. De Leo, A. Mohedas, B. Rajalingam, C.-L. Chen, *et al.*, "Cell and protein compatibility of parylene-C surfaces," *Langmuir*, vol. 23, pp. 11718-11725, 2007.
- [4] C. Shih, T. A. Harder, and Y.-C. Tai, "Yield strength of thin-film parylene-C," *Microsystem Technologies*, vol. 10, pp. 407-411, 2004.
- [5] D. A. Ateya, A. A. Shah, and S. Z. Hua, "Impedance-based response of an electrolytic gas bubble to pressure in microfluidic channels," *Sensors and Actuators, A: Physical*, vol. 122, pp. 235-241, 2005.
- [6] J. E. B. Randles, "Kinetics of Rapid Electrode Reactions," *Discussions of the Faraday Society*, vol. 1, pp. 11-19, 1947.
- [7] B. Ran and J. Katz, "The response of microscopic bubbles to sudden changes in the ambient pressure," *Journal of Fluid Mechanics*, vol. 224, pp. 91-115, 1991.
- [8] E. Meng, P.-Y. Li, and Y.-C. Tai, "Plasma removal of Parylene C," *Journal of Micromechanics and Microengineering*, vol. 18, p. 045004, 2008.
- [9] B. J. Kim, C. A. Gutierrez, G. A. Gerhardt, and E. Meng, "Parylene-based electrochemical-MEMS force sensor array for assessing neural probe insertion mechanics," in *Micro Electro Mechanical Systems (MEMS), 2012 IEEE 25th International Conference on*, 2012, pp. 124-127.
- [10] P. S. Epstein and M. S. Plesset, "On the Stability of Gas Bubbles in Liquid-Gas Solutions," *Journal of Chemical Physics*, vol. 18, pp. 1505-1509, 1950.

## CONTACT

\*E. Meng, tel: +1-213-8213949; ellis.meng@usc.edu