

An Experimental Investigation Into the Relationship Between Temperature-Time History and Surface Roughness in the Spray Quenching of Aluminum Parts

John D. Bernardin
Graduate Research Assistant.

Issam Mudawar
Professor and Director.

Boiling and Two-Phase Flow Laboratory,
School of Mechanical Engineering, Purdue
University,
West Lafayette, IN 47907

Repeated heat-quench cycles of Al-1100 samples resulted in increased surface roughness and corresponding shifts in the temperature-time cooling curve towards shorter overall quench periods. Three different types of initial surface roughness were applied to the test samples: polished, particle blasted, and milled finishes. For each of the three test surfaces, cooling curve shifts during repeated heat-quench cycles were accompanied by surface roughening, the shift was smallest with the milled sample. The surface roughness was examined with the aid of scanning electron microscopy, surface contact profilometry, and X-ray photoelectron spectroscopy. Surface profiles obtained via the profilometer revealed, on a relative basis, significant changes in surface roughness on the polished and particle blasted surfaces but not on the milled (roughest) surface. The roughening was the result of (a) hydrogen diffusion associated with oxidation, (b) oxidation buildup, and, to a lesser extent, (c) expulsion of impurities along dendrite boundaries. The hydrogen diffusion caused localized pressure buildup within the surface and along grain boundaries resulting in the formation of both microscopic (1 to 10 μm) features on the polished and particle blasted surfaces and relatively large (20 to 1000 μm) bumps and blisters on the particle blasted surface. It is shown how these wide spectrum surface roughness features affect cooling rate by (a) raising the Leidenfrost temperature separating the film and transition boiling regimes, (b) increasing the number of boiling sites on the quenched surface, and (c) altering the impact dynamics of the spray drops.

1 Introduction

Aluminum has been used extensively in the aerospace industry for its high strength-to-weight ratio and corrosion resistance. Recently, these same attributes, coupled with the promise of full recyclability, have made aluminum a possible substitute fact, production of the so-called "aluminum intensive vehicles" is currently underway in Europe; American automakers plan to introduce their own within a few years. Light-weight aluminum components may also compensate for the relatively low power of electric vehicles. The success of these vehicles is expected to be heavily dependent upon the automakers' ability to both reduce cost and establish reliable process models for critical aluminum making processes such as heat treatment.

Quenching constitutes the most crucial stage of heat treating, during which the part experiences a relatively large and rapid drop in temperature. This rapid cooling suppresses the precipitation of the alloying elements (solute), enabling controlled precipitation with subsequent artificial aging, which results in superior mechanical properties. The locus of points describing the cooling history of the part during the quench, as illustrated in Fig. 1(a) (described here for simplicity for the case of bath quenching), is commonly referred to as the quench curve or temperature-time cooling curve. This curve is divided into four boiling regimes. The heat transfer mechanisms and corresponding cooling performance in each regime are characteristically different, manifested by slope changes in the temperature-time

cooling curve. The quench commences with a relatively slow cooling rate in the film boiling regime, where surface temperature is typically too high to allow continuous liquid contact with the surface. Heat transfer in film boiling is dominated by conduction across a vapor blanket (film), which encases the surface at the onset of the quench, and subsequent evaporation of the vapor-liquid interface, and by radiation. Expectedly, the poor conductivity of the vapor greatly decreases cooling effectiveness of film boiling, resulting in a relatively slow cooling rate. As the quench progresses, the surface temperature decreases to a point where intermittent wetting of the surface is possible with partial breakup of the vapor blanket. The surface experiences an increase in cooling rate in this transition boiling regime. In the third regime, nucleate boiling, the entire surface becomes available for liquid contact and heat is released through bubble formation at the surface itself. It is in the nucleate boiling regime that the slope of the cooling curve is steepest. The cooling rate greatly diminishes in the single-phase regime as the surface temperature decreases asymptotically to the quenchant temperature.

The primary focus of the present study is heat treatment processes involving spray quenching. Spray quenching is preferred to bath quenching for two main reasons: faster cooling and the ability to cool both thick and thin sections of a part at the same rate by employing denser sprays upon the thicker sections. While the cooling curve for spray quenching generally follows the boiling regimes described above for bath quenching, the precise shape of a spray quench curve is highly dependent upon both the quenchant's thermophysical properties and the spray hydrodynamic parameters (spray volumetric flux, drop

Contributed by the Materials Division for Publication in the JOURNAL OF ENGINEERING MATERIALS AND TECHNOLOGY. Manuscript received by the Materials Division June 7, 1994; revised manuscript received March 3, 1995. Associate Technical Editor: K. S. Chan.

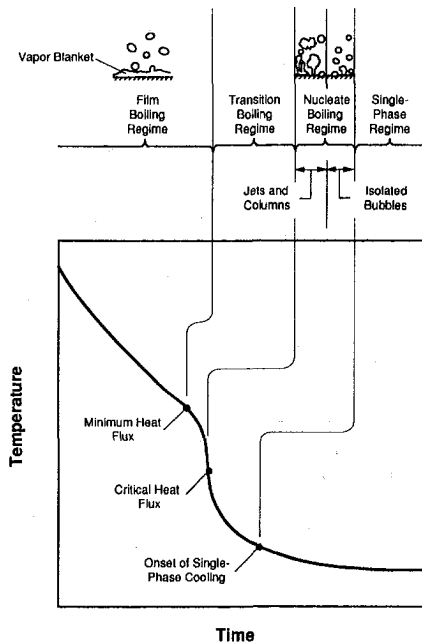

Fig. 1(a)

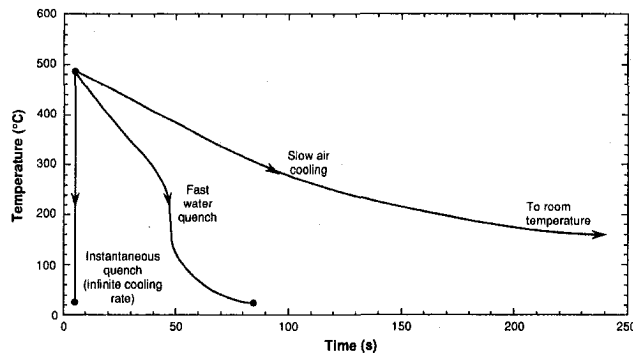

Fig. 1(b)

Fig. 1 (a) Temperature-time cooling curve for a metallic surface in a bath of liquid and (b) cooling curves for different cooling techniques

diameter, and drop velocity) as the spray heat transfer correlations of Mudawar and Valentine (1989) and Klinzing et al. (1992) suggest. Figure 1 (b) contrasts the cooling curve for spray quenching with those representing a virtually instantaneous quench (attainable only with very thin parts) and slow cooling in air.

Surface Roughness Effects on Quenching. It is well known that changes in surface features can have a profound effect on the boiling characteristics of metallic surfaces (Anderson and Mudawar, 1989), and should, therefore, affect the cooling history of metallic parts during a quench. Heat treatment of aluminum alloys, including exposure to both very high temperatures during solution heat treatment and coolant during the quench, can result in significant changes in surface features and, consequently, alter the cooling history during quenching from predictions based on correlations or models developed for polished, unoxidized surfaces. Many metallic parts actually acquire relatively large roughness features due to the forming process (e.g., extrusion, forging, or continuous casting). Accurate prediction of the cooling history for these parts requires an understanding of both how the original surface features influence the various boiling mechanisms during quenching, and how these surface features are themselves altered during the quench, leading to additional changes in the cooling history.

Several correlations are available for predicting film boiling, transition boiling (Klinzing et al., 1992; Rozzi et al., 1992), nucleate boiling, and single-phase liquid cooling (Mudawar and Valentine, 1989) with sprays. However, these correlations have been developed for polished and unoxidized (gold plated) surfaces. Some indication of roughness effects on spray quenching comes from a recent study by Pais et al. (1992). Unfortunately, the relationship between surface roughness and spray quenching is not well understood.

Changes in the spray quenching heat transfer rate due to roughness changes are far more complex than those associated with bath quenching. Surface features (and changes thereof) can affect the shape of a spray cooling curve to various degrees. Like bath quenching, 1 to 20 μm features will affect transition and nucleate boiling by the creation of bubble nucleation sites within the impinging spray drops, which can intensify boiling activity and augment cooling rate. Features approaching the size of a spray drop (20 to 1000 μm), on the other hand, will have a profound effect on the impact history (film spreading and breakup) of the drop as shown in a study by one of the authors using high speed photography (Bernardin, 1993).

Of greater importance is the temperature corresponding to the Leidenfrost point (the minimum film boiling point), which separates the low heat flux film boiling regime from the high heat flux transition boiling regime. The location of this temperature is critical in spray quenching since slight changes in its value can yield significant changes in the overall quench period. The Leidenfrost point is highly dependent on surface roughness. Bradfield (1966) noted that contact between a liquid drop and a surface in the film boiling regime is more likely to occur when rough protruding surface elements are present. Cumo et al. (1969) found the Leidenfrost temperature for water was 70°C higher for a gold plated copper particle blasted surface compared to a smooth lapped surface. In addition, studies by Baumeister et al. (1970), Baumeister and Simon (1973), and Nishio and Hirata (1978) found that rougher and fouled surfaces have higher Leidenfrost temperatures; that is, they quench faster. Thus, variations in surface roughness over both relatively small and large length scales should have a noticeable effect on the shape of the cooling curve and, hence, on cooling rate.

Figure 2 shows the dramatic effect of surface roughness on the Leidenfrost temperature for water drops on an aluminum surface. Displayed in the figure are evaporation times for individual sessile drops as a function of surface temperature for three different surface roughnesses. Small evaporation times are indicative of liquid-surface contact, while large evaporation times correspond to film boiling where the liquid is separated from the surface by a vapor blanket. The maximum evaporation time corresponds to the Leidenfrost point and represents the minimum temperature to support stable film boiling. At temper-

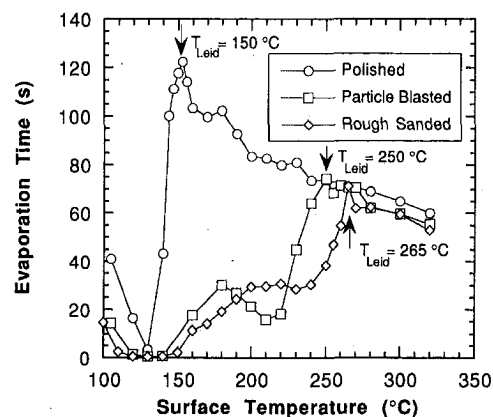

Fig. 2 Determination of the Leidenfrost point in sessile water drops evaporating on aluminum surfaces with different roughnesses

atures below this point, liquid-solid contact occurs and the evaporation time decreases considerably. Figure 2 clearly illustrates rougher surfaces possess higher Leidenfrost temperatures; i.e., they quench faster.

The present investigation was spurred by changes observed by Rozzi (1991) in the cooling curve of a square bar of Al-1100 during repeated heat-quench cycles as shown in Fig. 3. Shown are shifts in the cooling curve which were speculated to result from the incremental roughening observed on the surface following each heat-quench cycle. Since the operating conditions were identical for each cycle and the pure aluminum did not experience microstructural changes except on the surface, it is reasonable to conclude that the observed changes in surface roughness were responsible for the changes in cooling rate. The purpose of the present study is to determine the factors responsible for changes in surface roughness for aluminum parts undergoing various heat-quench processes and explore the impact of these changes on cooling rate. Examined in this study are the effects of both (a) the original surface roughness and (b) any additional roughening occurring during the heat-quench cycle. Samples with different initial roughness are tested for surface feature changes before and after repeated heat-quench cycles with the aid of scanning electron microscopy (SEM) and surface contact profilometry. In addition, X-ray photoelectron spectroscopy (XPS) is used to determine the amount of chemical deposition and oxidation on the sample's surface.

2 Experimental Methods

Test Samples. The test samples used in this study were fabricated from Al-1100, a 99.0% pure, relatively high oxidation-resistant aluminum alloy which produces gradual, controlled oxide buildup following a heat-quench cycle. Figures 4(a) and 4(b) show the two sample geometries which were used as dictated by availability of stock from which the samples were cut. The test samples were either disks, 8.57 cm in diameter, or 7.62 cm squares, both had an equal thickness of 0.80 cm. Each sample was instrumented with a single Chromel-Alumel (type K) thermocouple, which was insulated with magnesium oxide powder inside a 0.08 cm diam. Inconel sheath. The exposed thermocouple bead was pressed into the thermocouple hole which was prepacked with boron nitride powder of high thermal conductivity to ensure good thermal contact between the bead and test sample.

Three different types of surface finishes were applied to the samples after they were cut and milled to size. The smoothest,

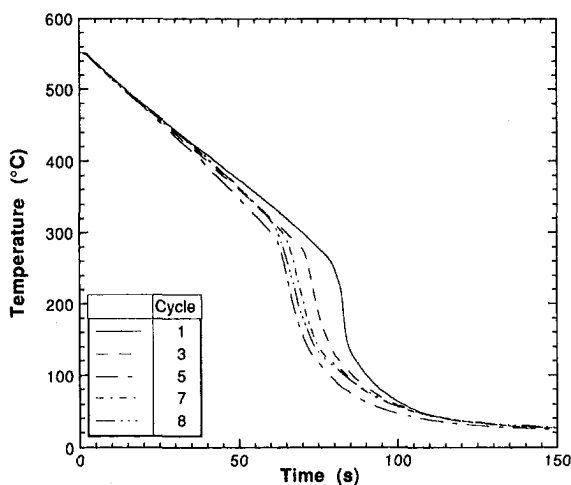

Fig. 3 Cooling curves measured by a thermocouple in a square, particle blasted bar of Al-1100 for repeated heat-quench cycles (adapted from Rozzi, 1991)

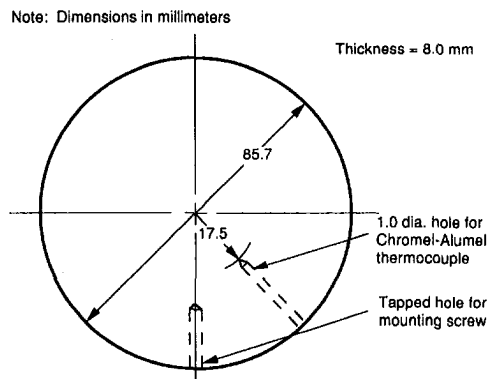

Fig. 4(a)

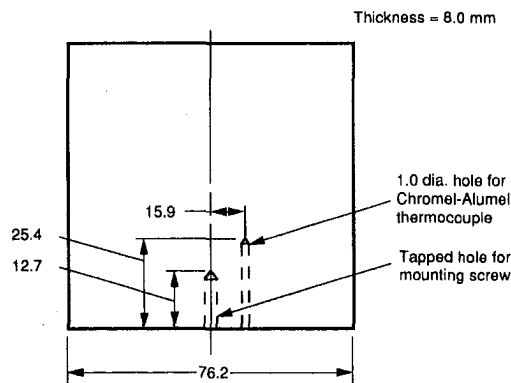

Fig. 4(b)

Fig. 4 Schematics for the (a) disk and (b) square test samples

a mechanical mirror polished finish, was created with a series of four polishing wheels with increasingly finer grit: 320 grit silicon carbide, 600 grit silicon carbide, 6 μm diamond, and 0.05 μm alumina. A silica particle blaster was used to create the second type of surface finish, a particle blasted surface with an average cavity diameter of 5 to 10 μm . A milled surface constituted the third finish which had a much larger average roughness than the other two finishes. These surface finishes were selected because of their ease in preparation as well as their popularity in laboratory investigations of spray heat transfer. There does not exist a single type of surface roughness for extruded or cast samples, thus the choice was made to use widely different surface finishes in the present study.

Test Apparatus and Procedure. The heat-quench process was performed using the materials processing test bed illustrated in Fig. 5. The test bed included a furnace, sample translation platform, and a spray quenching chamber. Tests were initiated by mounting the sample onto the translation platform and connecting the sample's thermocouple leads to a computer driven Keithley 500 data acquisition system. The furnace controllers were then set to initiate furnace heat-up. The furnace required approximately 5 hours to reach steady-state temperature, after which the sample translation platform was raised into the furnace with the aid of a counterweight pulley system. The sample heat-up was designed to simulate solution heat treatment of actual aluminum alloys (Al-1100 is not a heat treatable alloy). The data acquisition system allowed the operators to monitor the sample's temperature continuously during the heat-up. Upon reaching a sample temperature of 555°C, the translation platform was lowered from the furnace into the spray chamber. Two different cooling methods, spray quenching and natural air convection, were used to cool the sample to 22°C. In the spray quenching tests, a flat fan water spray was positioned to impact

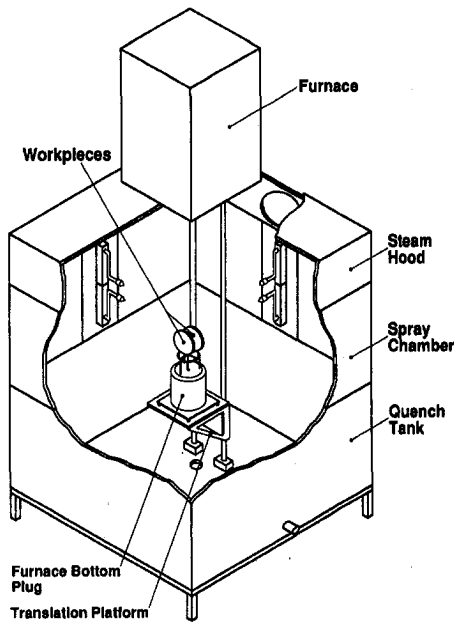

Fig. 5 Cut-away view of the materials processing test bed

one face of the sample. This spray had an average drop velocity of 13.5 m/s and a Sauter Mean Diameter (SMD) of 0.286 mm. The data acquisition program was executed the instant the sample was removed from the furnace, and the thermocouple temperature was recorded every 20 μ s. For the air cooled tests, a similar experimental procedure was employed except that the sample was cooled in open air rather than in the quench chamber.

Prior to and following each heat-quench cycle, the surface roughness of the sample was measured using an Alpha-Step 2000 profilometer manufactured by Tencor Instruments. A 1.5 μ m radius diamond tip stylus with a force of 3 mg traversed the sample surface over a scan length of 2000 μ m with a scan resolution of 1 μ m. A total of 10 scans were made along symmetrical axes on the surface of each sample, 5 scans from left to right and 5 from top to bottom, at a separation distance of approximately 10 mm. Surface roughness was also examined by a Jeol JSM-T300 scanning electron microscope equipped with an X-ray chemical analyzer. In addition, the surface chemistry was analyzed using X-ray photoelectron spectroscopy (XPS) to determine the amount of water mineral deposition and surface oxidation.

3 Experimental Results

Quench Data. As presented earlier in Fig. 3, repeated heat-quench cycles caused a square aluminum bar to quench at a quicker rate as evident in the cooling curve shift with each cycle. This shift was speculated to be the result of changes in quench performance caused by the incremental changes in surface roughness. With this in mind, the relationship between surface roughness and heat treatment was explored in the present study by subjecting samples with the three different initial surface finishes to repeated heat-quench cycles to investigate the magnitude of shifts in the cooling curve and ascertain if these shifts were accompanied by changes in surface roughness.

During repeated heat-quench cycles, the cooling curve was observed to shift towards a shorter quench period for each of the three test samples as shown in Figs. 6(a)–6(c) (the second cycle cooling curve for the polished sample was lost because electronic noise disrupted a major portion of the thermocouple data). The rate of cooling in the film boiling regime and, more importantly, the Leidenfrost point appear to change with multi-

ple quenches in the direction of faster cooling, these changes were smallest for the milled surface. As mentioned earlier, roughening of the surface affects the quench performance both by changing the cavity size distribution and the drop impact history. For the experimental temperature range and quench periods of the present test samples, radiation heat transfer was negligible; therefore, changes in surface radiation properties could not have produced the measured changes in cooling rate. The cooling curves given in Figs. 6(a)–6(c) cannot be compared directly for the different samples due to differences in

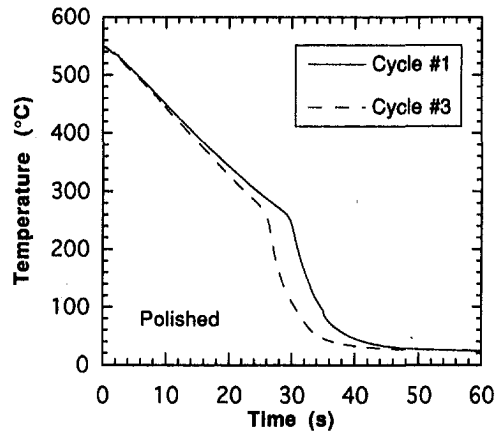

Fig. 6(a)

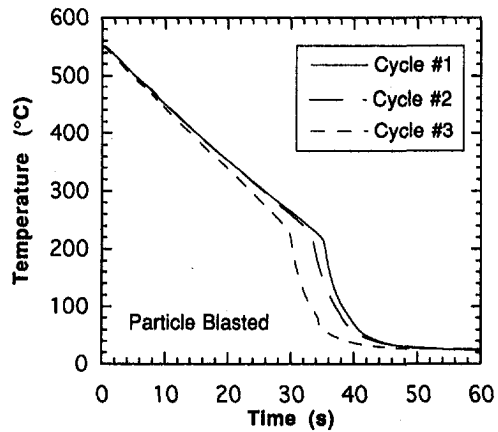

Fig. 6(b)

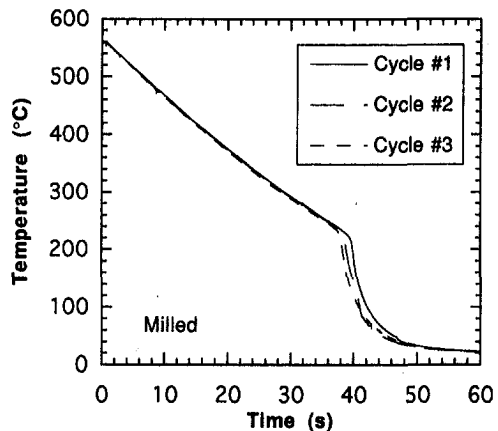

Fig. 6(c)

Fig. 6 Cooling curves for samples with (a) polished, (b) particle blasted, and (c) milled surfaces for repeated heat-quench cycles

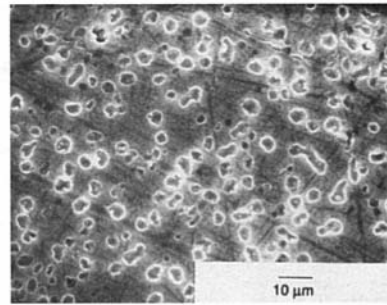
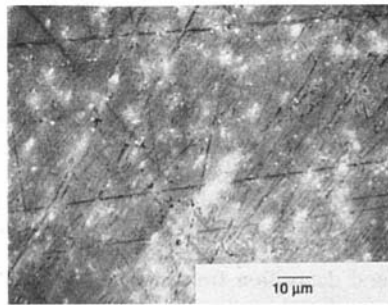

Fig. 7(a)

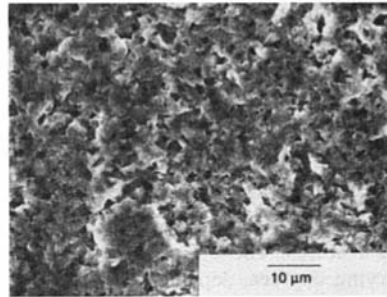
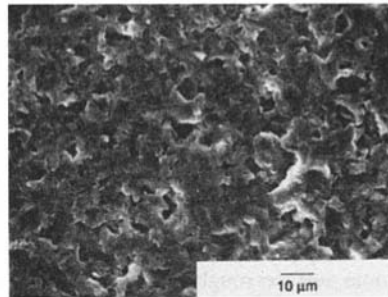

Fig. 7(b)

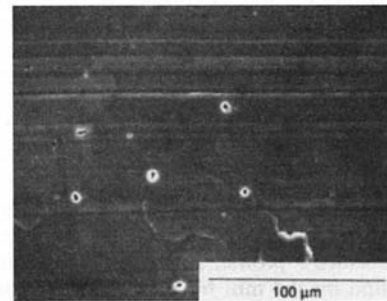
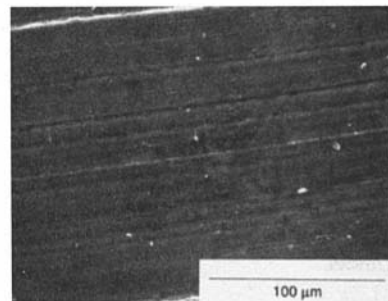

Fig. 7(c)

Fig. 7 Scanning electron microscope images of samples with (a) polished, (b) particle blasted, and (c) milled surfaces before and after a heat-quench cycle. The polished surface was cooled by natural convection in air and the other two samples by a water spray.

both sample geometries and thermocouple locations. Previous extensive experiments by Rozzi (1991) showed reproducible enhanced cooling trends for aluminum test specimens undergoing repeated heat-quench cycles. Thus, it was deemed unnecessary to present superfluous repeatability results for the present test samples.

SEM Results. Figure 7(a) shows SEM images for a polished sample before and after a simulated heat treating cycle consisting of a heat-up followed by natural convection cooling in air. Before the heat-cool cycle, the surface appears very clean, marred only by small polishing scratches less than about one micron wide. Following the cooling process, an oxide layer left the polished sample with a dull finish and numerous pits (dark holes surrounded by highlighted ridges). These pits range in size from 2 to 5 μm and were dispersed over the sample's surface.

Figure 7(b) shows SEM images of the particle blasted sample before and after a heat-quench cycle with the cooling performed with a water spray. Particle blasting creates a leafy surface structure with features not as distinctly defined as those on the polished sample. Prior to heating, the surface contained cavities which were larger in size but fewer in number than those following the heat-quench cycle. The cavities of the original surface

ranged in size from 1 to 10 μm , and those after the heat-quench cycle from 1 to 3 μm .

Roughening on a scale much larger than that depicted in the SEM images emerged on the surface of the particle blasted sample. Following repeated heat-quench cycles, large surface blisters, some having an average diameter equal to about a millimeter, were observed on both the sprayed and unsprayed surfaces, as shown in Fig. 8. In the upper right-hand corner of the photograph, one of the blisters has been deformed with a fine-edged tool, indicating a void beneath the surface. The blis-

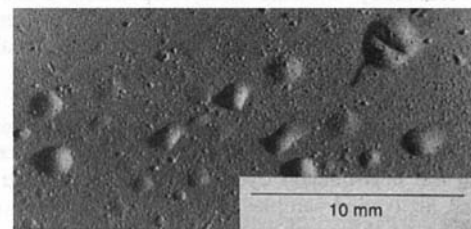

Fig. 8 Blisters on the particle blasted surface following a heat-quench cycle

tering phenomenon was only observed on the particle blasted surface.

Figure 7(c) depicts surface features of the milled sample before and after a heat-quench cycle, again with the quench performed with a water spray. Visible in both photographs are series of grooves formed by the milling process. The original surface was also marred by a few small pits which were preserved following the machining. Following the heat-quench cycle, a greater number of pits on the order of $10\ \mu\text{m}$ are shown sparsely dispersed across the surface.

Surface Profiles Results. A key advantage to using the profilometer is its ability to detect surface imperfections over a much broader range of surface length scales than manifested in the SEM images. The largest of these imperfections play a more significant role in altering the impact of spray drops than they do in the creation of bubble nucleation sites within the individual drops.

Figures 9(a)–9(c) show typical surface profiles of the polished, particle blasted, and milled surfaces, respectively, measured with the surface contact profilometer before and after a heat-quench cycle, each surface was cooled by spray quenching. The ordinate on the surface plots was magnified to enhance resolution of the surface features. These plots show evidence of profile changes to varying degrees, depending on the initial surface roughness. Average roughness, R_a , on the polished surface and particle blasted surface increased about four times and two times, respectively, while the milled surface showed only a small fractional increase. The polished sample's profile, Fig. 9(a), indicates roughening on a small length scale evidenced by more pronounced surface features following, as compared to before the heat-quench cycle. Large peaks with relatively large length scales, up to $200\ \mu\text{m}$, are visible in the particle blasted sample's post heat-quench profile, Fig. 9(b). This would indicate the formation of bumps or blisters of a roughness scale much larger than those associated with the particle blasting process used to create the original surface finish. The periodic features on the milled surface's profile, Fig. 9(c), represent surface grooves left behind by the mill bit as it traversed the surface. The pre and post heat-quench profiles for this sample are very similar; the minor differences are attributed to the different locations for the profile measurements.

It should be emphasized that the endpoints for each of the surface profiles shown in Figs. 9(a)–9(c) possess identical surface height values. This is a result of an automatic leveling process performed by the profilometer where the end point of the scan is shifted to the same height as the first point, with all points in-between being adjusted in a linear manner.

The microscopic changes (1 to $10\ \mu\text{m}$) on the polished and particle blasted surfaces and the larger blistering (20 to $1000\ \mu\text{m}$) on the particle blasted surface are of length scales which would affect the cooling rate in the following manners: (a) increasing the Leidenfrost temperature, (b) increasing the number of vapor production sites for boiling, and (c) altering the impact dynamics of the spray drops. These trends are justified by the quench curves of Fig. 6 which indicate increased Leidenfrost temperatures for each of the three test samples during repeated heat-quench cycles. Both the SEM images and surface contact profilometry indicate a corresponding increase in roughness for each case. In addition, earlier studies by Bernardin (1993) indicated surface roughness influenced the breakup of water drops impinging on a heated aluminum surface.

The air cooled samples were used to investigate the effects of spray drop impingement as well as the rate of cooling on surface roughness by removing the spray cooling process entirely from the heat-quench cycle. Surface profilometry data showed that air cooled samples experienced the same degree of roughening as the spray cooled samples. Thus, it can be concluded neither the spray impingement nor the cooling rate had significant effects on changes in the surface roughness.

X-Ray Photoelectron Spectroscopy (XPS) Results. X-ray photoelectron spectroscopy (XPS) was used following the heat-quench cycle to determine the amounts of (a) mineral deposition from the boiling water and (b) surface oxidation on the polished and particle blasted samples. Analysis of the milled surface was deemed unnecessary due to the comparatively insignificant roughening associated with this surface.

The XPS analysis showed, for both the polished and particle blasted samples, a 2 to $3\ \text{\AA}$ layer of mineral deposits consisting of calcium and magnesium was present. This would suggest mineral deposition from the boiling water could not produce any significant changes in surface roughness. XPS analysis also indicated silica was present in the amount of 5 to 6 percent to a depth of several hundred angstroms for both the polished and particle blasted samples. Since Al-1100 does not contain any silica, the source of the silica must have been the polishing and particle blasting since both contain silica-based abrasive.

The most significant finding from the XPS analysis was the presence of aluminum oxide with a mass percentage of nearly 85 percent to a depth of at least $500\ \text{\AA}$ and $800\ \text{\AA}$ for the polished and particle blasted surfaces, respectively. These thicknesses correspond to the point at which the XPS analysis was terminated, and the high oxide concentration suggests oxidation may extend deeper into the surface. It is not clearly known how absolute surface roughness affects oxidation. However, it can be speculated that the particle blasted surface would promote more oxidation than the polished surface can because of the higher surface area and, hence, larger number of sites available for oxidation. During the oxidation, ridges or platelets of oxide sometimes overlap and crack, resulting in a new surface structure. This might explain the creation of a large number of smaller features on the particle blasted surface following the heat-quench cycle. Oxidation is, therefore, an important contributor to the observed shifts in the cooling curve. Oxidation had an insignificant effect on the roughening and ensuing shifts in the cooling curve of the milled surface because the roughness changes on this surface were too small relative to the original roughness.

Hydrogen Diffusion Phenomenon. The above results and observations fail to explain both the extensive pitting and blistering occurring on the surface. Pits can result from expulsion of surface impurities (e.g., silica particles embedded during surface preparation) during the heat-up process as a result of uneven thermal expansion of the dissimilar materials. However, the small mass percentage of these impurities on all of the sample surfaces detected by the XPS analysis precludes the impurities expulsion as a major contributor to the cooling curve shifts.

A different phenomenon related to the oxidation process is suspected to be the chief contributor to the surface roughening and the corresponding cooling curve shifts. The most convincing hypothesis of the pitting and blistering of metal surfaces during high temperature heat treatment processes concerns the formation of atomic hydrogen following the reaction of water vapor with the aluminum surface in forming an oxide. Stroup (1942), Evans (1960), Fast (1965), Hunsicker (1967), and Evans (1968) reported harmful effects of the presence of moisture during the heat treatment of metallic alloys. In particular, the breakdown of water molecules during high temperature oxidation results in the formation of atomic hydrogen which diffuses into the metal surface where it combines to form molecular hydrogen at locations below the surface. Points of discontinuity such as small cavities or grain boundaries act as collection sites where the pressure created by the molecular hydrogen becomes great enough to form a blister or bump. As seen in the SEM images, the particle blasted surface is made up of a leafy structure which would provide an abundance of cavities and blister sources over a range of depths. Fast (1965) presented several photographs showing similar blister formations on copper and

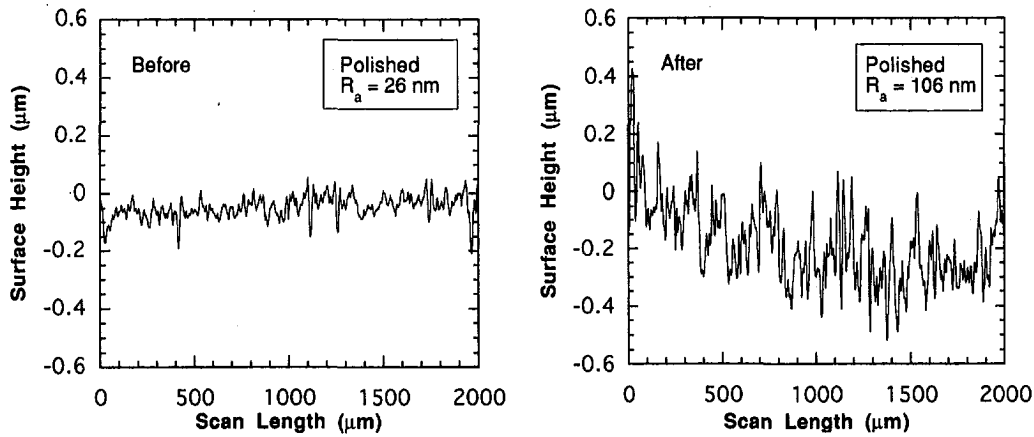

Fig. 9(a)

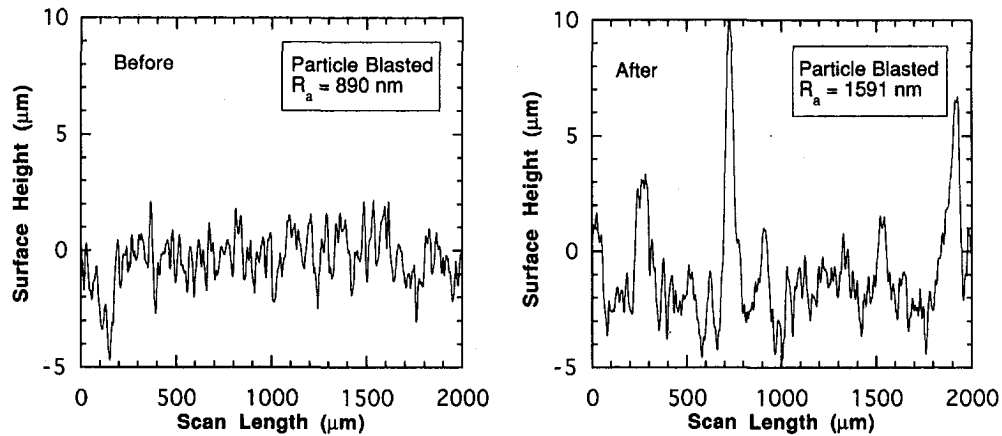

Fig. 9(b)

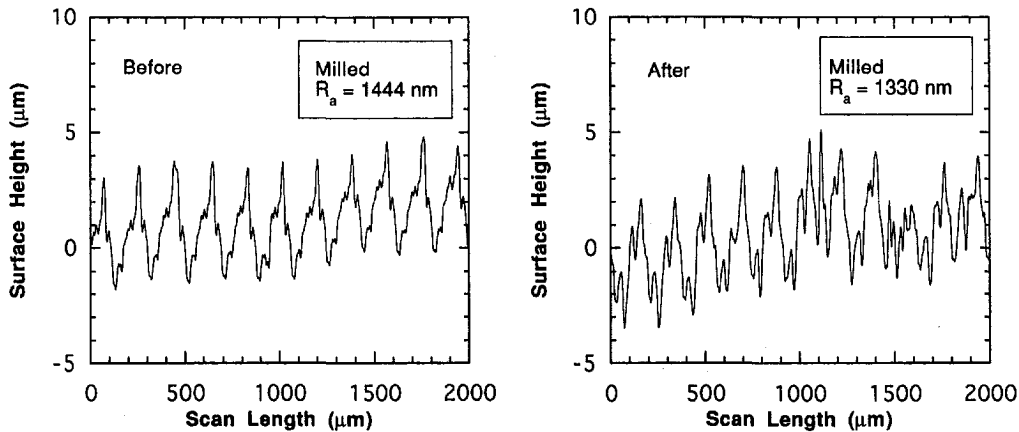

Fig. 9(c)

Fig. 9 Surface profiles for samples with (a) polished, (b) particle blasted, and (c) milled finishes before and after a heat-quench cycle

steel surfaces. Hunsicker reported that in high-temperature oxidation of aluminum, small voids may result from the hydrogen diffusion process. Fast also reported the existence of pits and surface cracks along grain boundaries as a result of hydrogen diffusion. The polished and milled surfaces in the present study experienced pitting rather than blistering. This most likely is a result of the absence of the leafy structure available for large scale blistering on the particle blasted surface. Points of discontinuity on the polished and milled surfaces lie closer to the surface and thus the surface is more susceptible to pitting caused by blister rupturing as shown by Tomashov (1966).

To examine the relative importance of the hydrogen diffusion process, the furnace insulating plug, which had cracks through which water was absorbed during previous quenches, was resealed with a cement paste and several tests were repeated for the polished and particle blasted samples. The pitting and blistering were drastically reduced and the percent change in roughness was reduced roughly by 50 and 90 percent for the polished and particle blasted surfaces, respectively. Lowering the furnace temperature from 555 to 495°C also had the same effect of virtually eliminating the pitting on the polished surface except along clearly defined dendrite boundaries as shown in Fig. 10.

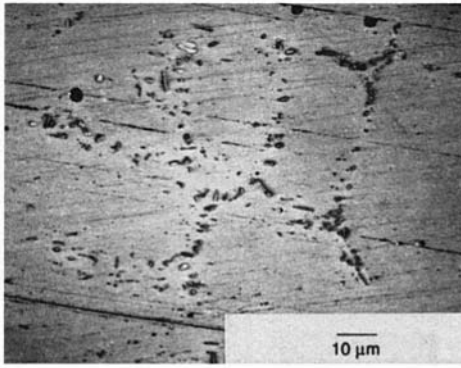

Fig. 10 Controlled pit formation along dendrite boundaries on the polished surface following a heat-quench cycle with the heating performed in a moisture free furnace

While the current study used exclusively Al-1100 samples with laboratory prepared surface finishes, investigations are underway to investigate similar aspects with an extruded commercial grade alloy, Al-2024. Continued efforts are also being made to quantify the effects of surface roughness on spray heat transfer, in particular the Leidenfrost point and drop impact behavior. In particular, experimental efforts are being pursued to determine deviations in polished surface heat transfer predictions as a result of surface roughening.

4 Conclusions

This paper examined surface roughening and its enhancement of cooling rate for Al-1100 samples with polished, particle blasted, and milled surface finishes following single and repeated heat-quench cycles. Key conclusions from this study are as follows:

- (1) The degree and type of surface roughening and corresponding shift in the cooling curve were found to depend upon initial surface finish.
- (2) The polished and particle blasted surfaces experienced cooling curve shifts towards shorter quench periods following repeated heat-quench cycles, the cooling curve shifts of the milled surface were comparatively small.
- (3) The polished and particle blasted surfaces, which experienced enhanced cooling rates, showed profound changes in surface roughness. These changes took the form of pitting on the polished surface and both oxidation and large scale blistering on the particle blasted surface. Any roughening in the milled surface was too small to be distinguished from the original surface features.
- (4) The key contributors to the enhancement in cooling rate for the polished and particle blasted surfaces are believed to be the hydrogen diffusion associated with oxidation, and oxidation buildup. Both these effects are more severe at higher temperatures and in moisture laden environments. A secondary effect is the expulsion of surface impurities due to differences in volumetric expansion coefficients between the metal and impurities.
- (5) Surface roughness influences cooling rate by creating both microscopic ($1-10\ \mu\text{m}$) pits, which augment bubble formation, and large ($20-1000\ \mu\text{m}$) roughness features which affect both the Leidenfrost temperature as

well as the impact history and ensuing heat transfer of the individual spray drops.

- (6) Surface roughness has a measurable influence on spray heat transfer. The extent of this effect must be quantified to develop useful empirical correlations which provide universal predictions of spray heat transfer for a wide variety of surface conditions.

Acknowledgements

Financial support for this work by the national Science Foundation through the Purdue University Engineering Research Center for Intelligent Manufacturing Systems is gratefully appreciated. The authors thank Messrs. Jerry Hagers and Rudolf Schick of Spraying Systems Company for supplying spray nozzles and performing spray characterization measurements, and Gerry Dail and William Arthur of Alcoa for providing aluminum samples for the present study. The authors also thank Professors David P. DeWitt, W. Nicholas Delgass, and David R. Gaskell for their helpful suggestions and Messrs. Mark Pellerin, Basil Bonner, and Zissis Dardas, all from Purdue University, for their technical support.

References

- Anderson, T. M. and Mudawar, I., 1989, "Microelectronic Cooling by Enhanced Pool Boiling of a Dielectric Fluorocarbon Liquid," *ASME Journal of Heat Transfer*, Vol. 111, pp. 752-759.
- Baumeister, K. J., Henry, R. E., and Simon, F. F., 1970, "Role of the Surface in the Measurement of the Leidenfrost Temperature," *Augmentation of Convective Heat and Mass Transfer*, A. E. Bergles, and R. L. Webb, eds., The American Society of Mechanical Engineers, New York, pp. 91-101.
- Baumeister, K. J., and Simon, F. F., 1973, "Leidenfrost Temperature-Its Correlation for Liquid Metals, Cryogenics, Hydrocarbons, and Water," *ASME Journal of Heat Transfer*, pp. 166-173.
- Bernardin, J. D., 1993, "Intelligent Heat Treatment of Aluminum Alloys: Material, Surface Roughness, and Droplet-Surface Interaction Characteristics," Masters thesis, School of Mechanical Engineering, Purdue University, West Lafayette, Indiana.
- Bradfield, W. S., 1966, "Liquid-Solid Contact in Stable Film Boiling," *I & E C Fundamentals*, Vol. 5, pp. 200-204.
- Cumo, M., Farello, G. E., and Ferrari, G., 1969, "Notes on Droplet Heat Transfer," *Chemical Engineering Progress Symposium Series*, Vol. 65, pp. 175-187.
- Evans, U. R., 1968, *The Corrosion and Oxidation of Metals: First Supplementary Volume*, St. Martin's Press, New York.
- Evans, U. R., 1960, *The Corrosion and Oxidation of Metals: Scientific Principles and Practical Applications*, Edward Arnold Publishers Ltd., London.
- Fast, J. D., 1965, *Interactions of Metals and Gases*, Academic Press, New York.
- Hunsicker, H. Y., 1967, "The Metallurgy of Heat Treatment," *Aluminum: Properties, Physical Metallurgy and Phase Diagrams*, Vol. 1, ASM, Metals Park, Ohio, pp. 109-162.
- Klinzing, W. P., Rozzi, J. C., and Mudawar, I., 1992, "Film and Transition Boiling Correlations for Quenching of Hot Surfaces with Water Sprays," *ASM J. Heat Treating*, Vol. 9, pp. 91-103.
- Mudawar, I., and Valentine, W. S., 1989, "Determination of the Local Quench Curve for Spray-Cooled Metallic Surfaces," *ASM J. Heat Treating*, Vol. 7, pp. 107-121.
- Nishio, S., and Hirata, M., 1978, "Study on the Leidenfrost Temperature (2nd Report, Behavior of Liquid-Solid Contact Surface and Leidenfrost Temperature)," *Trans. JSME*, Vol. 44, pp. 1335-1346.
- Pais, M. R., Chow, L. C., and Mahefkey, E. T., 1992, "Surface Roughness and its Effects on the Heat Transfer Mechanism in Spray Cooling," *ASME Journal Heat Transfer*, Vol. 114, pp. 211-219.
- Rozzi, J. C., 1991, "Quenching of Aluminum Parts having Irregular Geometries using Multiple Water Sprays," Masters thesis, School of Mechanical Engineering, Purdue University, West Lafayette, Indiana.
- Rozzi, J. C., Klinzing, W. P., and Mudawar, I., 1992, "Effects of Spray Configuration on the Uniformity of Cooling Rate and Hardness in the Quenching of Aluminum Parts with Non-Uniform Shapes," *J. Materials Engineering and Performance*, Vol. 1, pp. 49-60.
- Stroup, P. T., 1942, "Atmospheric Control in the Heat Treatment of Aluminum Products," *Controlled Atmospheres*, edited by American Society for Metals, Cleveland, pp. 207-220.