

EMBEDDED HARDWARE INTERFACING



OUTLINE

- Microcontroller Selection
- General Interfaces
- User I/O Interfaces
- Sensors
- Actuators and How to Control Them
- Memory
- Wired Interfaces
- Wireless Interfaces

MICROCONTROLLER SELECTION

Importance and Guidance

- Many different types and manufacturers w/ variety of metrics and capabilities
- Many selection considerations also apply to microprocessors, CPLDs, FPGAs, etc.
- 2 “phases” of microcontroller selection:
 1. Initial Prototyping/Proof of Concept: Choose an appropriate device family (parts within should be pin compatible) for the final product, then pick the most powerful device in that family
 2. Mature Prototype/Production: Based on your requirements from phase 1 (memory, etc.), refine your choice to a more cost-efficient part



MICROCONTROLLER SELECTION

Performance Considerations

- Speed (a.k.a. frequency) – How fast can your device run? (Generally measured in MHz)
- Power – How much power does your device consume? (Generally measured by current consumption in mA or μ A)
- Memory – How much onboard memory does your device have? (Measured in kB, typically)
- Voltage – What voltage range can your device operate at? (Lower voltages use less power for a given frequency)

MICROCONTROLLER SELECTION

Capability Considerations

- What onboard computational features does your device possess?
 - DSP operations (integrated multiply-accumulate, etc.)
 - Floating-point support?
 - Types of memory:
 - EEPROM – byte-addressable, nonvolatile
 - Flash – page-addressable, nonvolatile
 - RAM – byte addressable, volatile

MICROCONTROLLER SELECTION

Interface Considerations

- What peripherals does your device possess?
 - General μ C interfaces (recall from ECE362): I²C, SPI, UART, GPIO, ADC, PWM, etc.
 - DAC (Digital-to-Analog) – Improved performance over PWM w/ lowpass filter
 - Computing interfaces: USB, Ethernet, Bluetooth, etc.
 - Other specialty interfaces: 1-Wire, I²S, DMA, CAN, OBD-II, etc.
- Interfaces can be implemented in software

PURDUE (referred to as “bit-banging”)

MICROCONTROLLER SELECTION

Packaging Considerations

- Variety of device packages available
- Some packages are impossible to solder by hand (BGA, LGA, most QFN)
- Some packages contain under-chip pads used for heat dissipation and/or mechanical stability
- Recommendation: choose the most dense package variant for your desired part that you can solder by hand (for initial prototyping phase, at least)

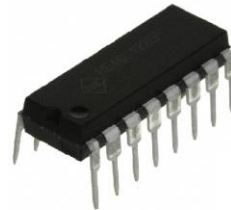

Dual Inline Package (DIP)



Small Outline Integrated Circuit (SOIC)



Shrink Small-Outline Package (SSOP)

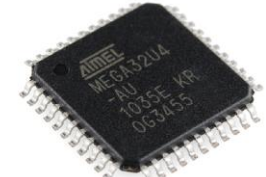

Quad Flat Pack (QFP)

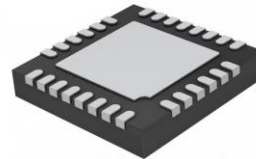

Quad Flat, No-Leads (QFN)



Ball Grid Array (BGA)

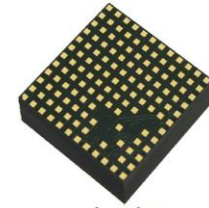

Land Grid Array (LGA)

MICROCONTROLLER SELECTION

Other Considerations

- Availability/cost of programming and debugging tools
- Availability/cost/usability of software development tools
- Age/status of the product. (Near end-of-life (EOL)? In production? Future product?)
- Ease of acquiring device samples.
- Ease of acquiring the microcontroller itself. Is it in stock? Can you get spares (2-3 spares)?
- Silicon-level bugs in the manufactured devices (IC manufacturers generally publish known bugs in “Silicon Errata” documents which are available online)

MICROCONTROLLER SELECTION

Manufacturers and Availability

- Various device manufacturers exist to research potential parts (use parametric selection tools to narrow offerings):
 - Microchip – <http://www.microchip.com>
 - Atmel – <http://www.atmel.com>
 - Texas Instruments – <http://www.ti.com>
 - Freescale Semiconductor – <http://www.freescale.com>
 - STMicroelectronics – <http://www.st.com>
 - Analog Devices – <http://www/analog.com>
 - NXP Semiconductors – <http://www.nxp.com>
 - Cypress Semiconductor - <http://www.cypress.com/>
- Parts can be purchased or sampled (in some cases)

GENERAL INTERFACING

Level Translation

- Various logic families (5V, 3.3V, 2.5V, 1.8V, etc.)
- Often necessary to convert from one voltage domain to another (e.g. a 3.3V microcontroller communicating with a 5V sensor)
- Different level translation techniques available depending on:
 - Duplex (one-way communication or bidirectional?)
 - Number of lines (1 line? Several?)
 - Speed of communications
- Dedicated ICs available, as well as analog methods (app notes available online)

GENERAL INTERFACING

Line Driving

- Amplifier used to boost the strength of analog/digital signals
- Typically used to drive signals over extended lengths of cable
- Often used in telecommunications, audio, and certain digital computing applications (RS-232, USB, etc.)
- ICs available from various manufacturers to perform line-driving functions

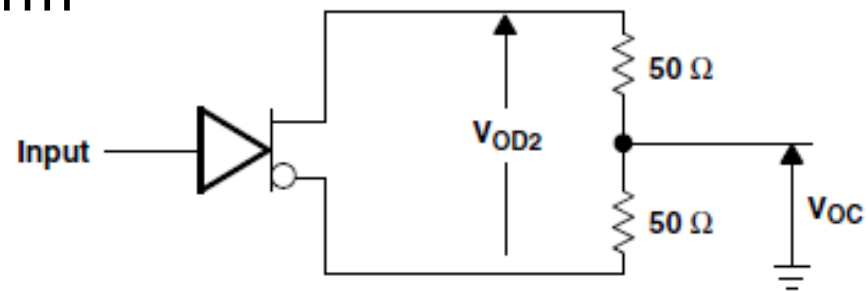

Figure 1. Differential and Common-Mode Output Voltages

GENERAL INTERFACING

Switching DC Loads – Transistors

- $\mu\text{C}/\text{FPGA}/\text{etc.}$ device pins are often incapable of sinking/sourcing sufficient current for a DC load
- BJTs and MOSFETS can be used as switches in these situations, allowing a load to be switched on or off

I_C : Collector current
 I_B : Base current
 h_{FE} : DC current gain

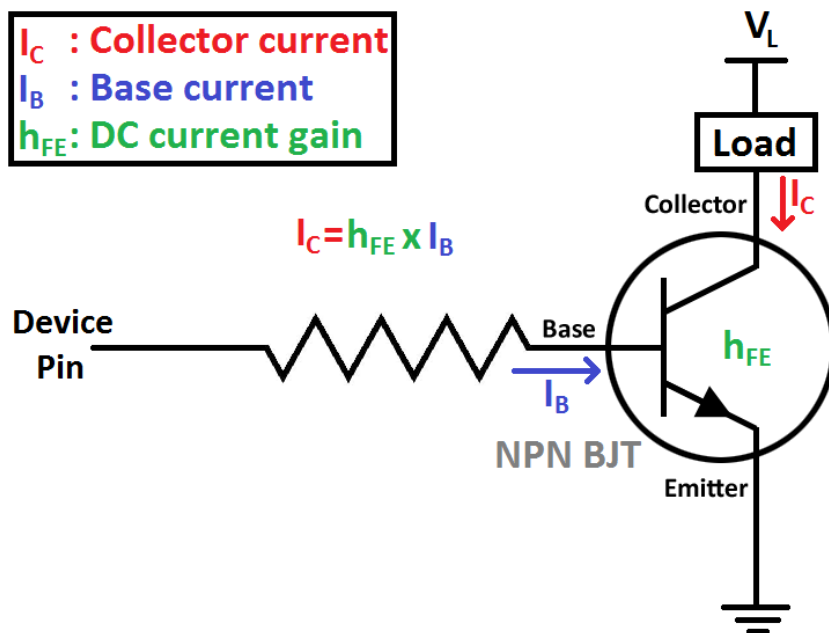

Parameters of Interest:

- $I_{D\text{max}}$ continuous
- V_{DS} breakdown
- $R_{DS(\text{on})}$ resistance

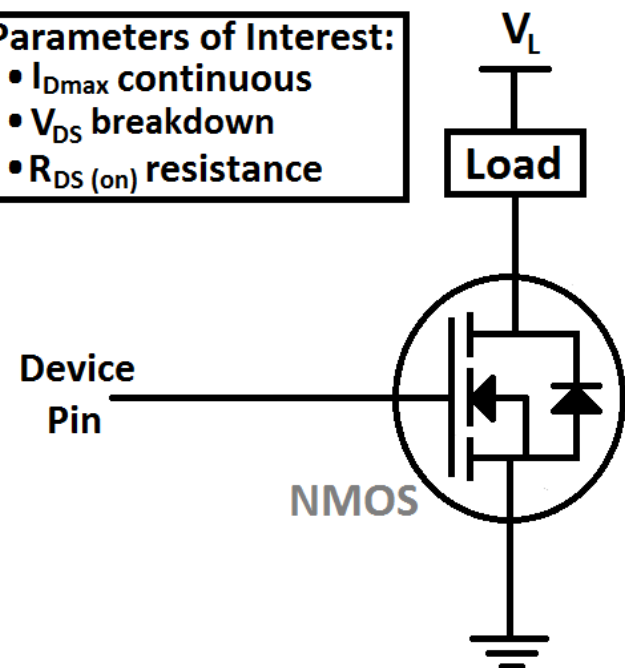

GENERAL INTERFACING

Switching DC Loads – Transistors 2

- Tradeoffs:
 - BJTs: May require substantial base current to achieve saturation (Darlington pairs often used to obtain high h_{FE} at high I_C)
 - MOSFETs: Require minimal gate current and less susceptible to thermal runaway; more expensive
- Inductive loads (relays, motors, etc.) may require an arc suppression diode (Energy stored in an inductive load must be dissipated; otherwise the “inductive kickback” can damage the switching device)

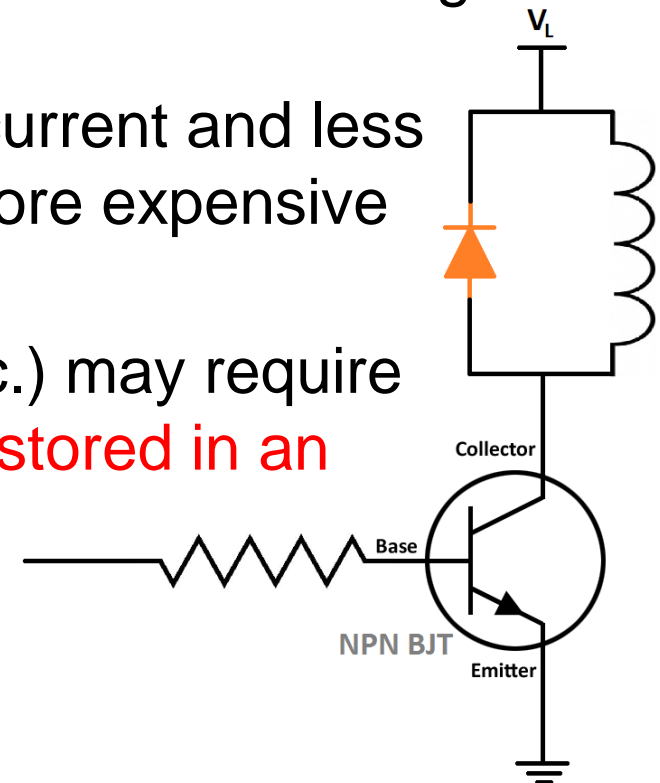

GENERAL INTERFACING

Switching DC Loads – Constant Current Drivers

- Some devices (LEDs, etc.) are sensitive to the current passed through them
- Even small changes in the forward voltage of the LED can lead to significant changes in the current flowing through the device (potential to cause damage)
- For these applications, constant current drivers may be desirable
- Drivers can be created using discrete parts or purchased as ICs

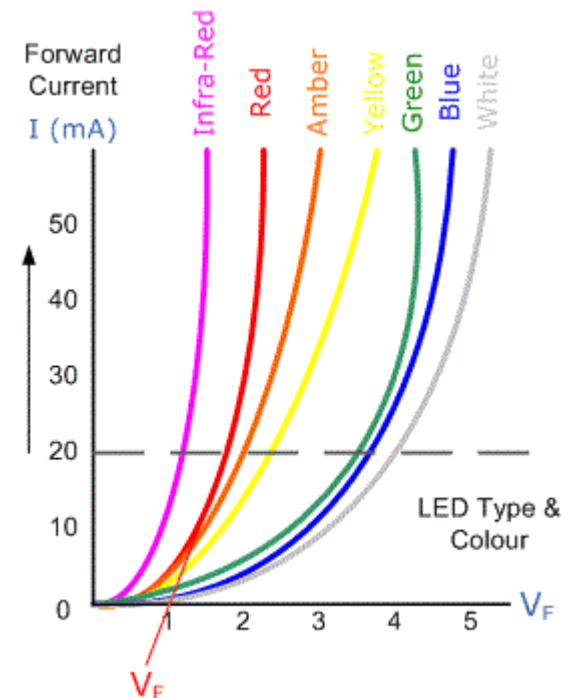
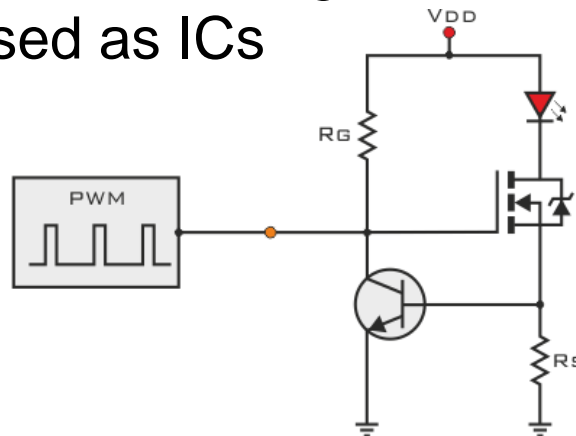

GENERAL INTERFACING

Pulse Width Modulation (PWM)

- Modulation technique in which the duty cycle of a pulsed signal is varied based on the transmitted data
- Can be implemented in software
- Major uses:
 - Reducing power consumption by devices (LEDs)
 - Motor speed control
 - Simple audio
 - Sensors

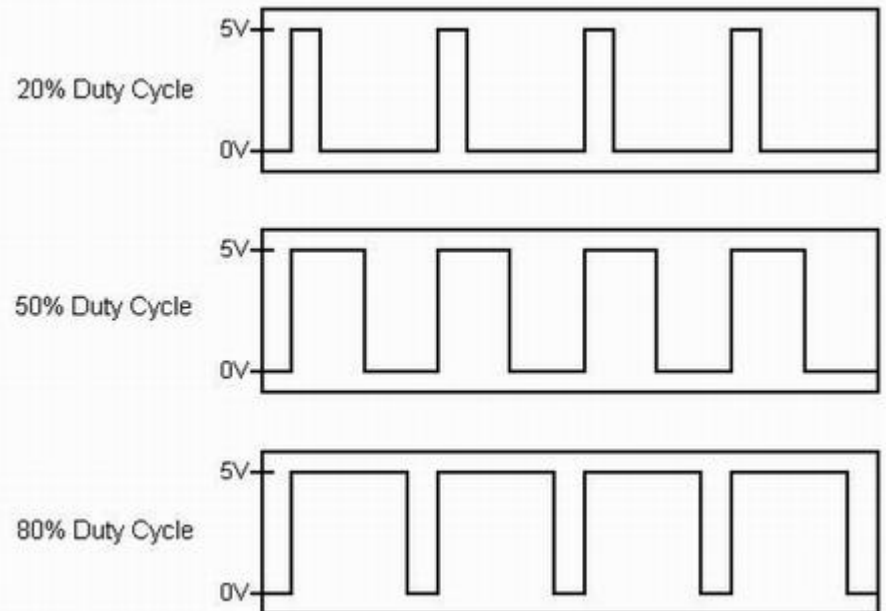

GENERAL INTERFACING

Switching AC Loads

- Sometimes needed for control of home appliances and devices (lamps, fans, etc.)
- Generally use relays or semiconductors:
 - Relay: Mechanical device triggered using an electromagnet
 - Semiconductors: Cheaper, higher reliability, less noisy, special control requirements
- Heat sinking and isolation usually required

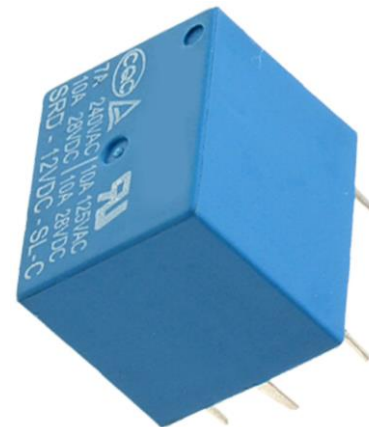

GENERAL INTERFACING

Isolation

- Isolation: The act of preventing current flow between 2 circuits by providing no direct conductive path between the elements of one circuit and those of another; often used in safety and reliability situations
- Isolation is often ideal when an electrical failure in one circuit (such as a high-power DC load) could cascade to and destroy another circuit (such as a microcontroller)
- **IMPORTANT: Isolated circuits CANNOT have a shared ground connection; a shared ground connection defeats any efforts to isolate the circuits**

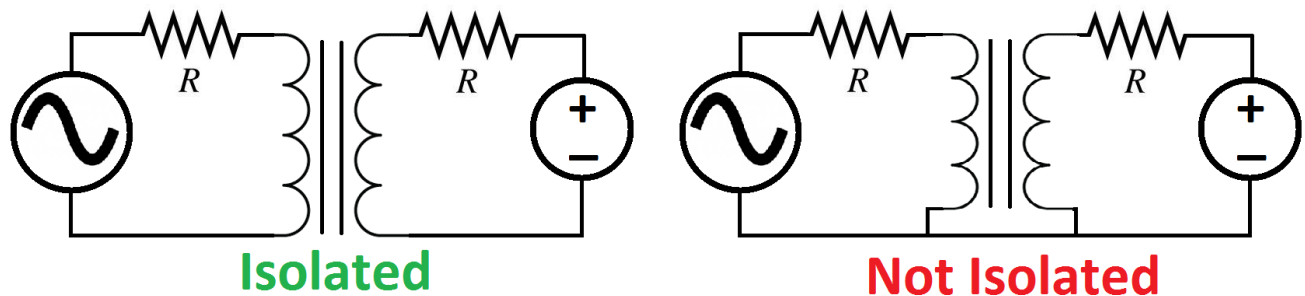

GENERAL INTERFACING

Isolation 2

- Numerous methods exist to provide isolation between circuits:
 - Transformers: Provide isolation via magnetic flux between coils
 - Opto-isolators/Optocouplers: Provide isolation via light transmitted over an air gap
 - Capacitors: Provide isolation via electric fields over an air gap (pass AC signals but not DC signals)
 - Hall-Effect Sensors: Use an inductor to transmit information across an air gap magnetically
 - Relays/Solenoids: Allow flow of electricity when closed, air gap when open

GENERAL INTERFACING

Isolation 3

- Places where isolation is often used:
 - Safety situations: An electrical failure could cause injury or death to a living thing
 - Mission-critical situations: An electrical failure could cause catastrophic damage or destruction of an expensive piece of equipment
 - High-power loads: (E.g. high-power LEDs, motors, etc.) An electrical failure could cascade and cause damage or destruction of critical circuitry such as a microcontroller or FPGA
 - At point-of-entry for offboard cables: A long offboard cable can act like a large antenna, allowing to pick up large, unexpected, and potentially damaging induced voltages and currents

USER I/O INTERFACING

Keypads and Switch Matrices

- Projects may call for a matrix of switches or switch-like elements (magnetic sensors, light sensors, etc.)
- Standard approach is to assert individual rows of the matrix and listen for signals on the columns of the matrix. (Repeatedly scan through each row of switch matrix). Can be performed by Keypad Encoder IC (or similar)
- Without proper care, “ghosting” or “masking” can occur on a keypad matrix when attempting to detect multiple key presses
- An excellent writeup on switch matrices can be found here:

http://www.dribin.org/dave/keyboard/one_html/

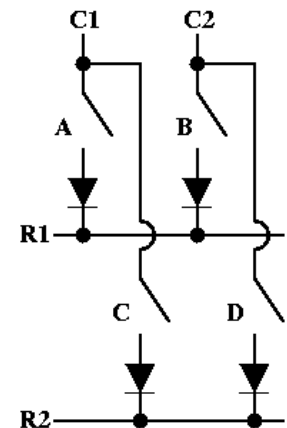

USER I/O INTERFACING

Rotary Encoders

- Convert the angular position or motion of a shaft into an analog or digital code
- Often used on user interfaces as knobs, particularly in instances when unlimited rotation is desirable

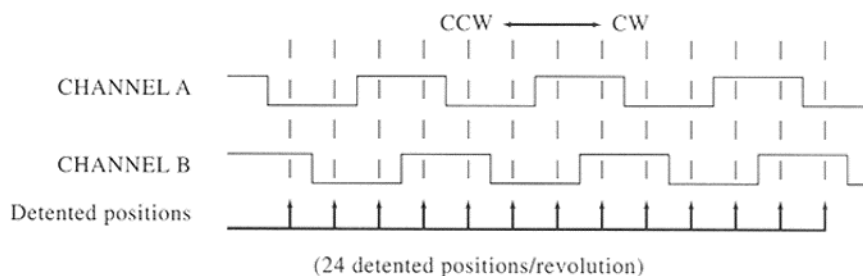

AB: 10 → 11 → 01 → 00 → 11 ... CCW rotation

AB: 10 → 00 → 01 → 11 → 10 ... CW rotation

CODE	CONDITION
0	got interrupt, but no change in code read
1	clock-wise (single bit change)
2	counter clock wise (single bit change)
3	error (both bits change)

PREV	CURR	LOOK-UP CODE	COMMENTS
00	00	db 0	00 → 00, no change
00	01	db 1	00 → 01, CW
00	10	db 2	00 → 10, CCW
00	11	db 3	00 → 11, error
01	00	db 2	01 → 00, CCW
01	01	db 0	01 → 01, no change
01	10	db 3	01 → 10, error
01	11	db 1	01 → 11, CW
10	00	db 1	01 → 00, CW
10	01	db 3	10 → 01, error
10	10	db 0	10 → 10, no change
10	11	db 2	10 → 11, CCW
11	00	db 3	11 → 00, error
11	01	db 2	11 → 01, CCW
11	10	db 1	11 → 10, CW
11	11	db 0	11 → 11, no change

USER I/O INTERFACING

Knobs and Sliders

- Sliders and knobs are generally available as potentiometers
- Linear scales and logarithmic scales available (log scale potentiometers often used in audio and video applications)
- Reading slider value is as simple as performing A/D conversion on the potentiometer value



USER I/O INTERFACING

LEDS

- Many types: Discrete, 7-segment display, LED strip, LED meter, etc.
- Variety of colors: single color, bicolor, RGB, etc. (color of LED influences forward voltage of LED)



USER I/O INTERFACING

Character LCDs

- Used to display dot-matrix characters
- Available in various colors, backlight colors, widths, heights, and operating voltages
- Various interfaces available; most character LCDs are ultimately based on the Hitachi HD44780 LCD controller
- It is possible to store a limited number of custom characters onto LCD displays for custom graphics. One writeup on the subject is available here:
http://www.pyroelectro.com/tutorials/16x2_lcd_custom_character/index.html



USER I/O INTERFACING

Graphical LCDs

- Provide more flexible and sophisticated options than character LCDs
- Variety of colors, screen sizes (measured in pixels), interfaces, voltages, etc.
- Generally necessitate the use of libraries such as graphics libraries, fonts, drawing APIs, etc. in order to use effectively



USER I/O INTERFACING

Touchscreen LCDs

- Adds user interface layer to existing graphical display
- 2 major touch technologies: resistive and capacitive
- Generally necessitate the use of libraries such as graphics libraries, fonts, drawing APIs, etc. in order to use effectively
- Generally necessitate the use of dedicated display driver hardware (μ C offloads graphics commands to display driver)



USER I/O INTERFACING

Esoteric Display Options

- Nixie Tubes: Numbers displayed using gas tubes (similar in function to a neon sign)
- Electromagnetic Dot Display: Uses magnets to flip dots into on or off position

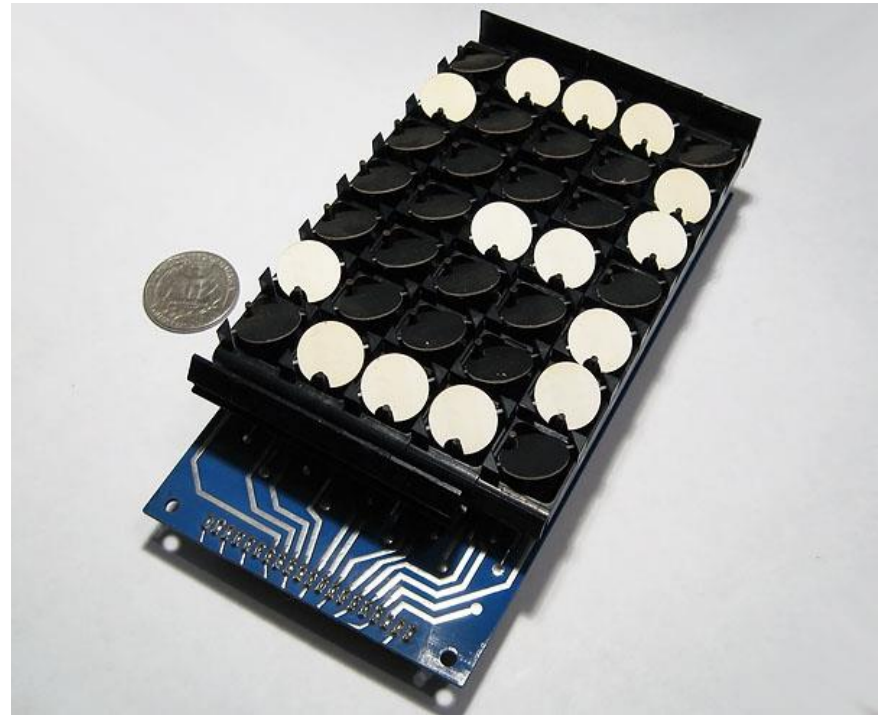

USER I/O INTERFACING

Emerging Display Options

- Electronic Paper:
 - Reflects light, rather than emitting it (saving power)
 - Flexible
 - Capable of retaining static text and images indefinitely without application of power



SENSORS

Light, Color, and Imaging

- Light-sensing techniques:
 - Photodiode/Phototransistor: Conductivity is determined by level of light exposure (tuned to various wavelengths of light)
 - Solar Cell: Supplies current proportional to incident light on the solar cell surface

Spectral Response

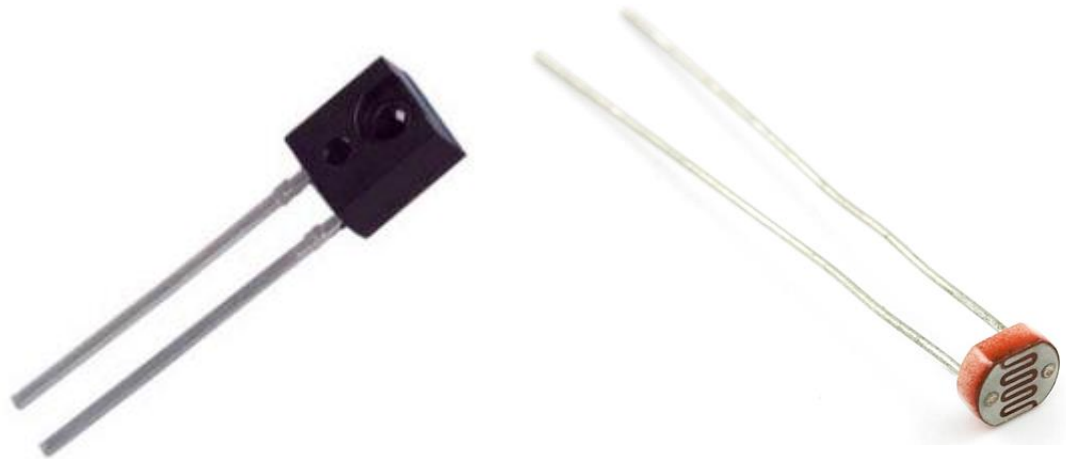
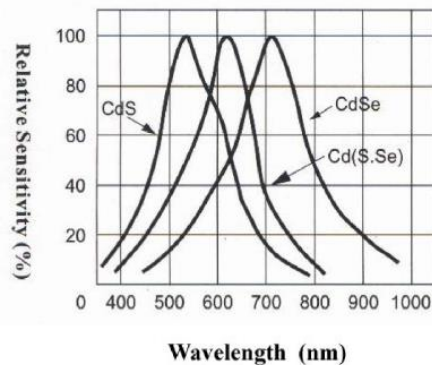

SENSORS

Light, Color, and Imaging

- Color sensing techniques:
 - Dedicated color sensors: Finely tuned photocells to detect RGB color wavelengths
 - LEDs: Can reverse-bias and use as a color-sensing device
 - Cameras: Can use cameras in conjunction with image processing software (OpenCV, etc.) to detect colored objects

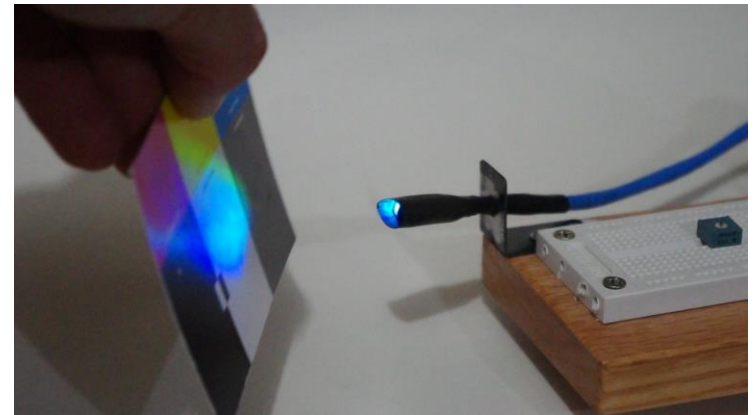
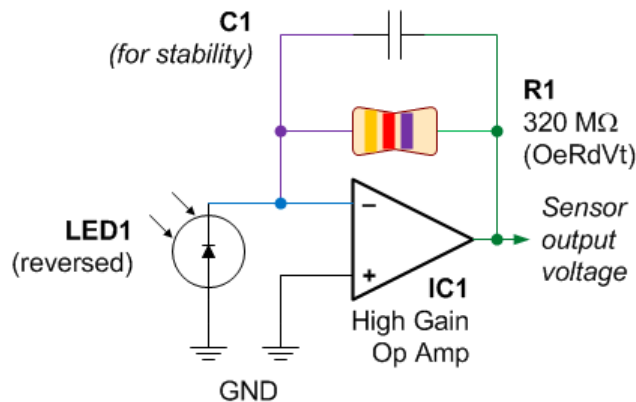

SENSORS

Video/Photo Imaging

- CMOS/Cellular Cameras readily available
- Computational considerations: speed, resolution, frame rate, processing latency, memory/buffering considerations
- Generally require additional hardware considerations (motherboards, embedded drivers, dedicated hardware, etc.)

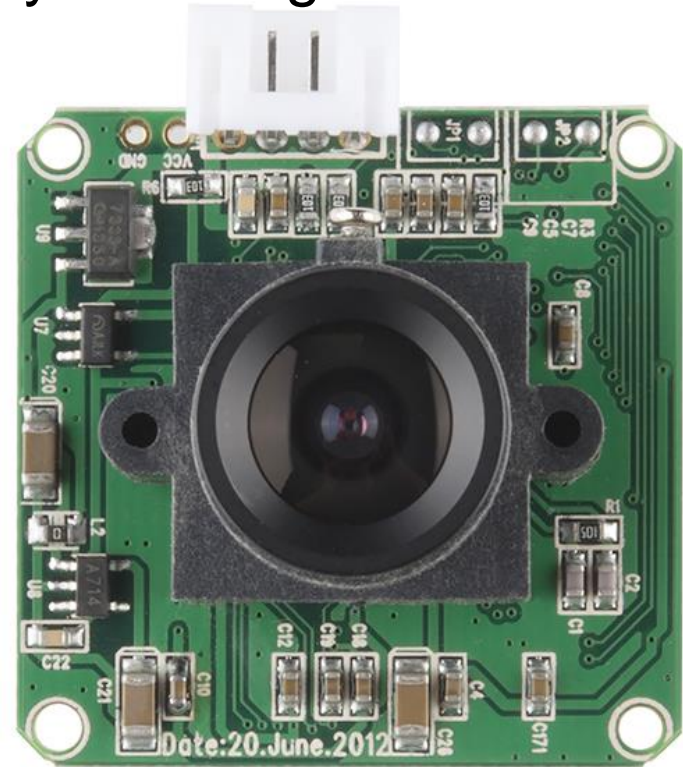

SENSORS

Motion, Position, and Orientation

- Gyroscopes: Measures orientation based on angular momentum principles
- Compass: Senses orientation relative to magnetic fields
- GPS: Senses position by measuring received signals in satellite constellation and calculating satellite delays
- IMU: Inertial measurement unit; uses gyros, compasses, and accelerometers to accurately determine position and velocity of objects

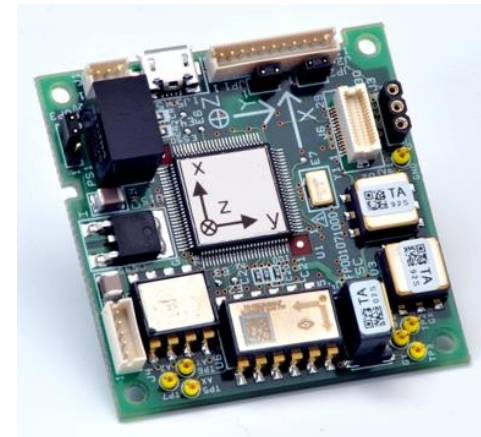

SENSORS

Motion, Position, and Orientation

- Accelerometers: Use MEMS and piezoelectric materials to measure force applied to a known mass ($F = ma$)
- Altimeters/Barometers: Determine the height/altitude of an object by measuring atmospheric pressure
- Shaft Encoders: Measure rotations of an axle, then use known properties of the wheel to determine distance traveled

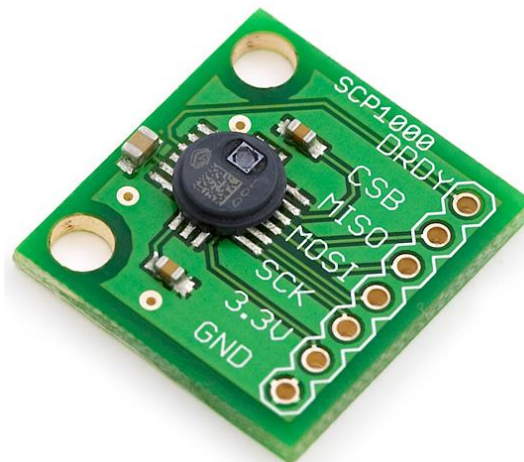
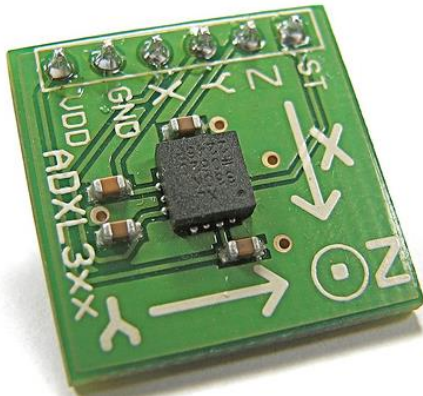

SENSORS

Proximity and Ranging

- Hall Effect Sensor: Measure presence of (nearby) magnetic fields
- Rangefinder: Measure distance to an object through various methods
 - Sonar/Ultrasonic: Sound waves
 - Radar: Radio waves
 - Lidar: Light waves
 - Infrared: IR light



SENSORS

Heat and Temperature

- Thermocouple: Measures the voltage induced by the temperature gradient between dissimilar metals
- Thermistor: Resistor whose resistance changes significantly as a function of temperature
- Infrared: Measure heat by measuring the emitted infrared radiation



SENSORS

Sound and Vibration

- Microphone: (Electret type most common) – Uses dielectric material and diaphragm to detect sound
- Piezoelectric: Materials which convert mechanical vibrations into electrical charge. Used in microphones and other sensors (such as flex sensors)

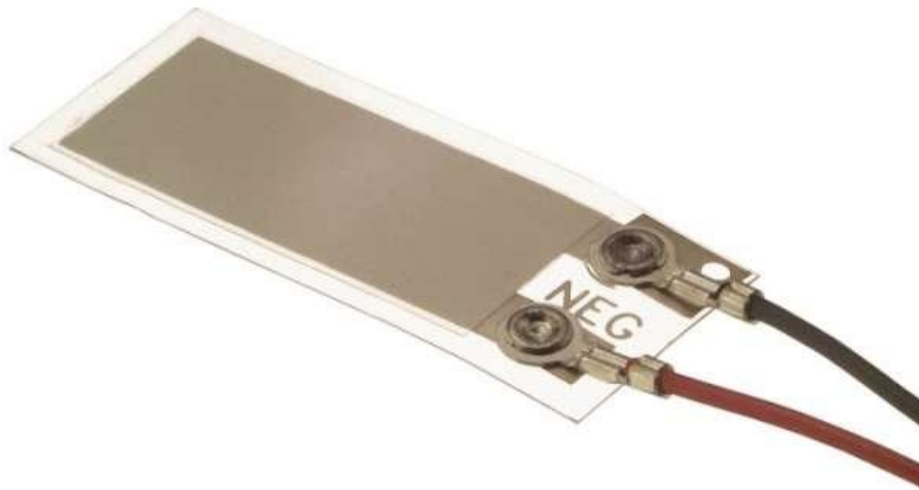

SENSORS

Chemical and Biological

- Fingerprint Scanners: User authentication and security applications
- Gas Sensors: Used to detect the presence of methane, CO, CO₂, O₂, H₂, and other gases
- Electrokardiogram (EKG): Used in heartbeat detection
- Electroencephelogram (EEG): Used in brainwave detection

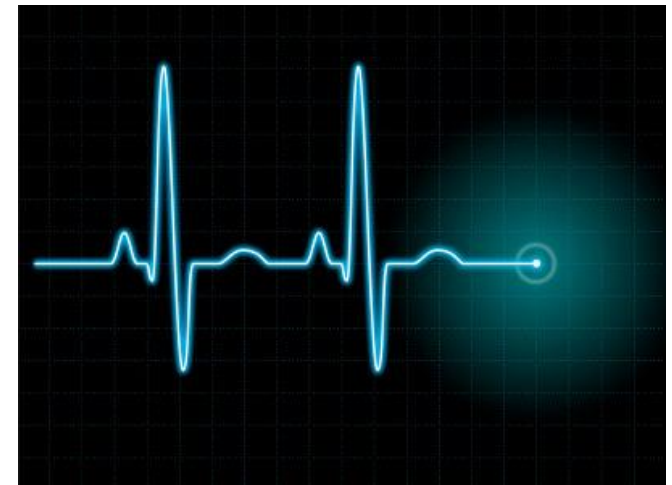

ACTUATORS AND CONTROL

Light

- Light Bulbs: Create light through use of a heated filament (or ionized channel, in case of fluorescent bulbs)
- LEDs: Create light using semiconductor properties
- Laser Diodes: Similar to LEDs, but generate lasers
- **Bright light sources and lasers require special safety considerations (eye protection)**

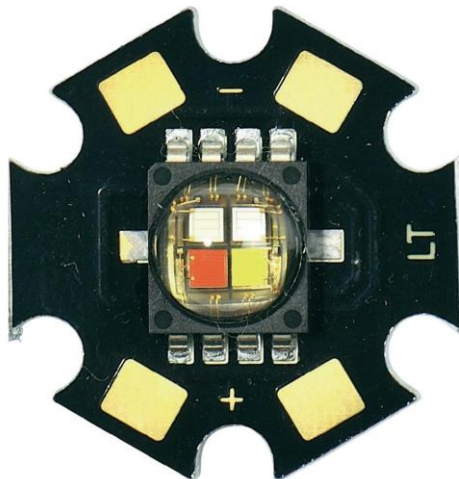

ACTUATORS AND CONTROL

Light Control

- LEDs:
 - High-power LEDs: Require DC switching techniques, may require constant current drivers
 - Many LEDs: May require dedicated driver chip
 - Multiplexing: Switch groups of LEDs on and off quickly (reduces power consumption)
 - Charlieplexing: Technique for driving large numbers of LEDs from few device pins
- Light bulbs: Require AC switching techniques (relays, triacs, etc.)
- Laser diodes: Require DC switching techniques

ACTUATORS AND CONTROL

Audio

- Buzzer: Converts electricity to frequency tones
- Speaker: Converts electricity to sound
 - Dynamic Loudspeaker: Uses magnetic coil to vibrate diaphragm; good frequency response
 - Piezoelectric Speaker: Uses piezoelectric materials; poor frequency response but compact and durable

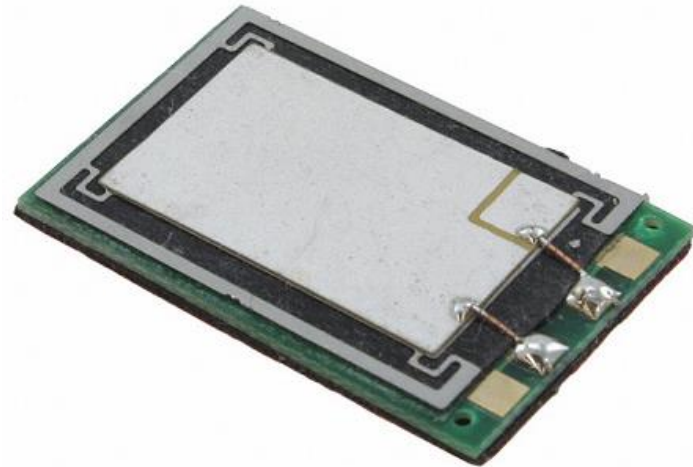
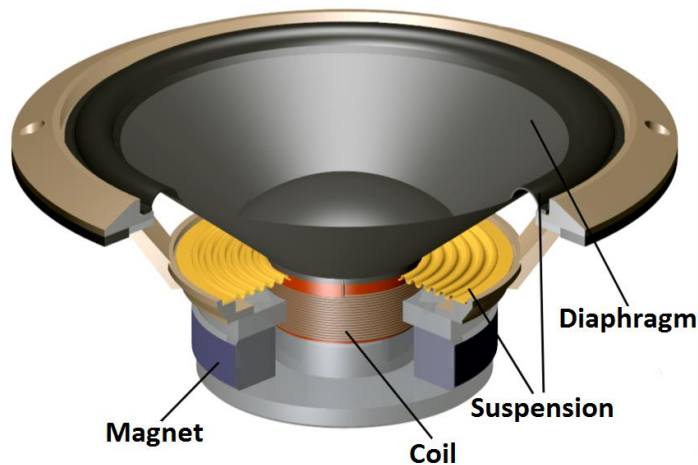

ACTUATORS AND CONTROL

Audio Control

- Filtering needed to condition input and remove noise
- Amplification generally needed (control sound volume):
 - “Class A” Amplifier: Simple, great performance, horrible efficiency (25-50% max depending on techniques)
 - “Class B” Amplifier: Improved efficiency (~78.5% max), distortion and performance issues
 - “Class AB” Amplifier: Compromise between A and B approaches; medium efficiency and performance
 - “Class C” Amplifier: Exists, but not recommended for audio applications
- Amplifier techniques can be used for other applications (driving radio signals, motor control, etc.)

ACTUATORS AND CONTROL

Audio Control 2

- “Class D” Amplifier:
 - Uses transistors as switches rather than linear amplifiers
 - Output signal is modulated (PWM, delta-sigma, etc.), then fed to the amplifier
 - Pros: extremely power efficient with good performance
 - Cons: complexity
 - ICs available to perform this functionality and reduce complexity requirements

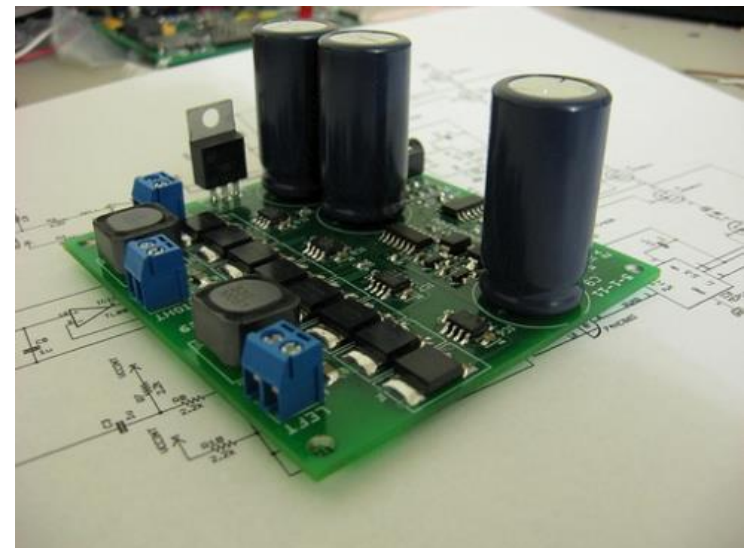

ACTUATORS AND CONTROL

Thermal

- Wire Heaters: Highly resistive wire which generates heat when current is passed through (similar to filaments in a toaster – Nichrome and Tungsten popular options)
- Peltier Cooler: Uses electricity to generate a temperature differential (Used in some cooling applications)

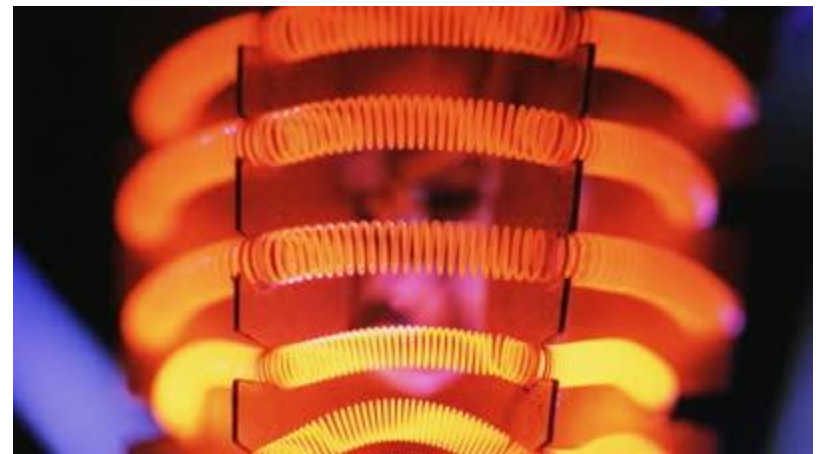
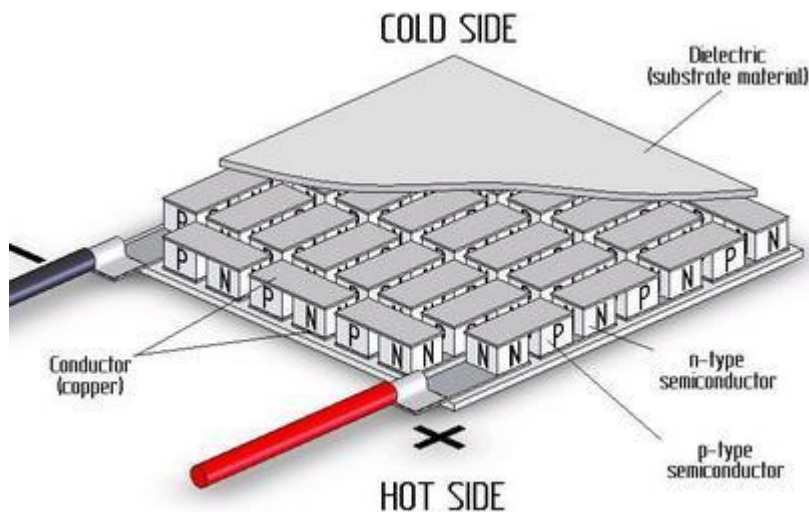

ACTUATORS AND CONTROL

Motion: Motors

- DC Motors: Use oscillating electromagnetic fields to produce continuous rotation
 - Brushed DC: Uses an internal commutator and conductive brushes to mechanically switch the magnetic field (low cost, simple control, lower life span)
 - Brushless DC (BDC): Utilizes permanent magnet for switching of magnetic field, external commutation (higher cost, more complicated control, higher reliability)

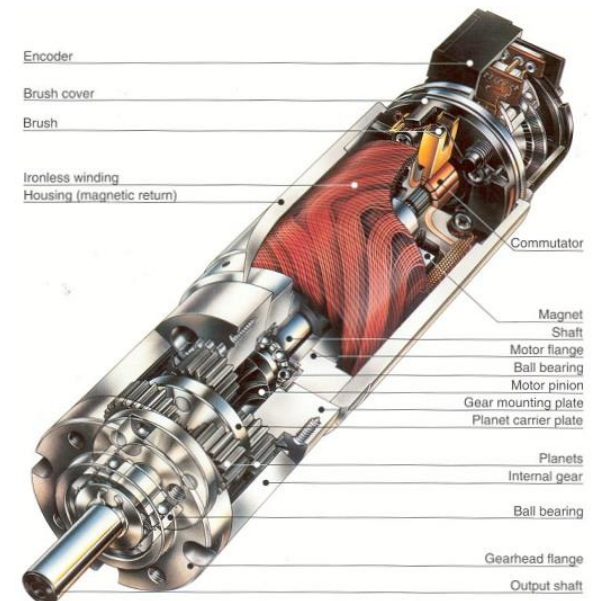

ACTUATORS AND CONTROL

Motion: Motors 2

- Stepper Motors: Similar to brushless DC, but produce motion in discretized steps rather than smooth motion. Sophisticated control schemes generally used; partial step motion is possible under certain control schemes
- Servos: Designed to travel to a specific rotational angle based on a provided digital value. Motion limited to $\sim 270^\circ$ without modification.



ACTUATORS AND CONTROL

Motion: Other

- Linear Actuators: Convert electricity into linear motion (solenoids, mechanical conversion of rotational to linear motion)
- Muscle Wire/Shape memory alloy: Material changes shape when electric current applied; used to imitate biological muscles

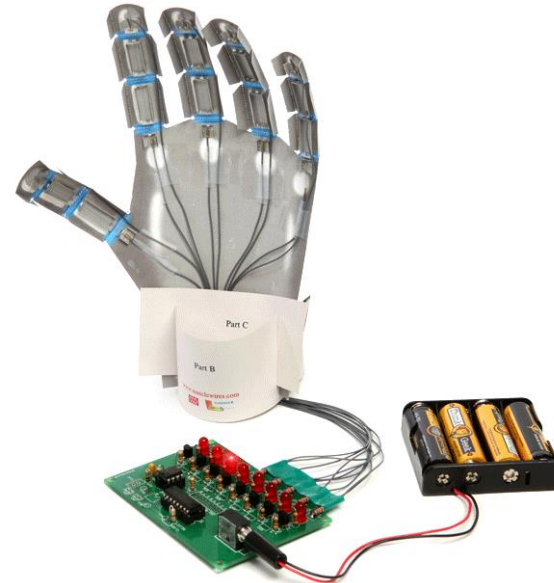

ACTUATORS AND CONTROL

Motion: Other 2

- Pumps: Used to transport fluids throughout a system
 - Important: some pumps must have fluids in them to work while others can be run dry.
- Pneumatics: Air used to control motion of system parts
- Hydraulics: Water, oil, or other liquid used for motion

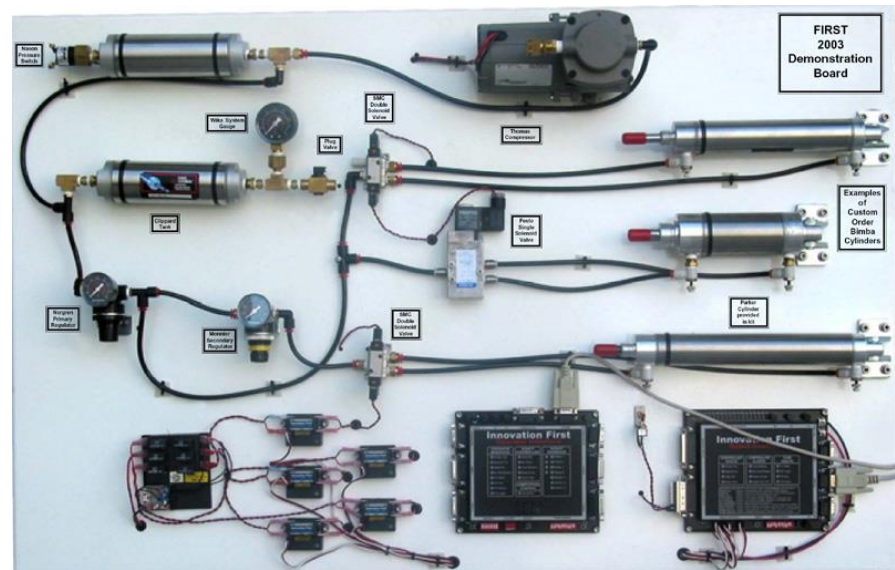

ACTUATORS AND CONTROL

Motion: DC Motor Control

- H-Bridge: Transistor circuit commonly used to control the direction of a DC motor (PWM input waveforms commonly used for speed control)
- Transistors used as switches; arranged in “H” pattern

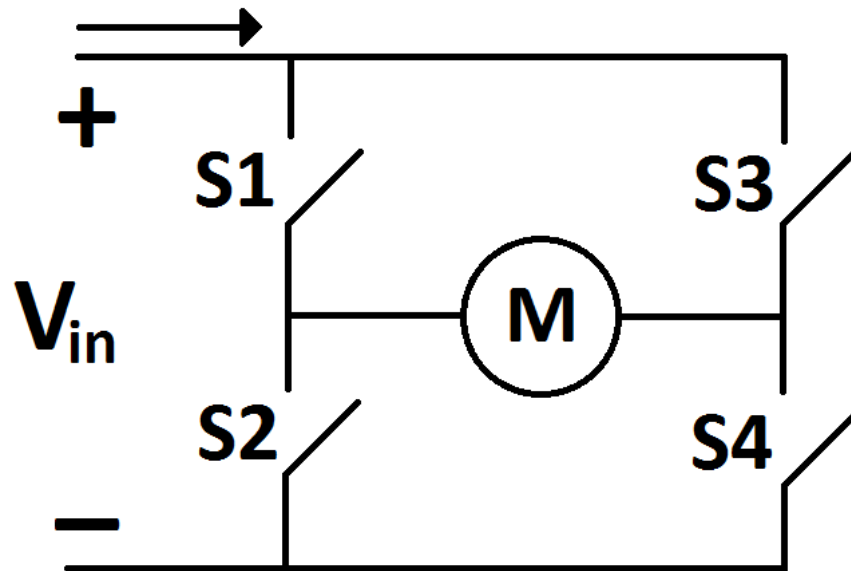

S1	S2	S3	S4	State
0	0	0	0	Coasting
1	0	0	1	Forward
0	1	1	0	Reverse
1	0	1	0	Braking
0	1	0	1	Braking

ACTUATORS AND CONTROL

Motion: Stepper Motor Control

- Stepper motor stator and rotor consist of wound coils
- Stepping through rotation in a given direction is a matter of activating the coils in a specific sequence (partial stepping control options available)

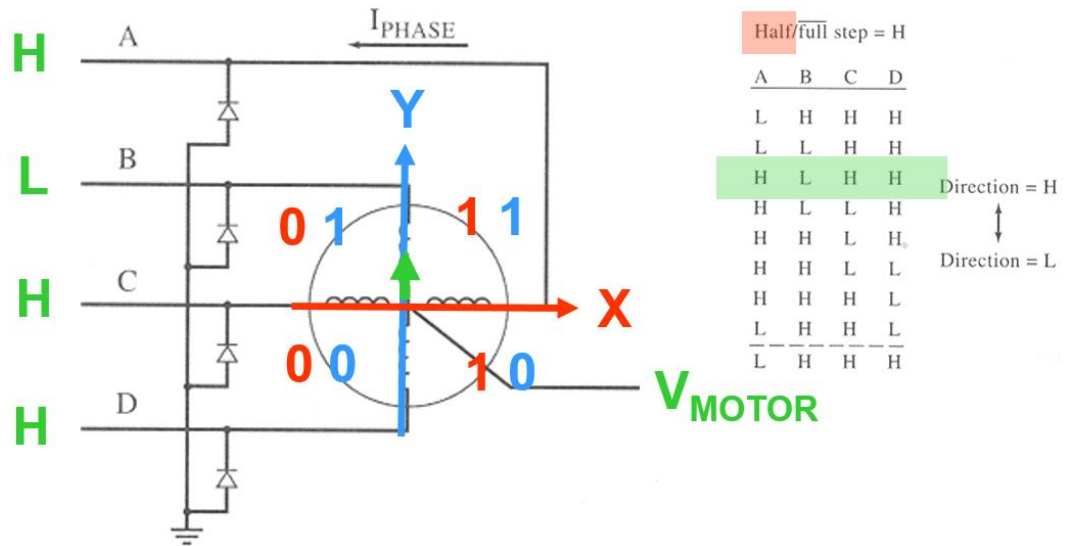
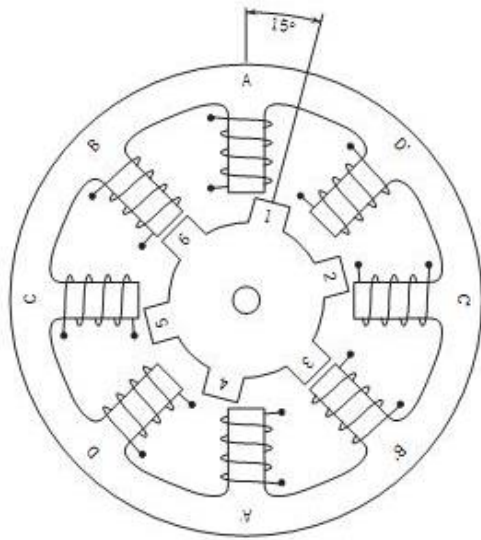

MEMORY

- 2 categories of memory:
 - Volatile: State lost when power is removed
 - Nonvolatile: State retained when power is removed
- Types of memory:
 - EEPROM: Byte addressable, nonvolatile, smaller sizes (~8MB), fast access times
 - Flash: Page addressable (256-512B/page), nonvolatile, large sizes available (32GB+), slow access times
 - SRAM (Static RAM): Volatile, low power, dual-port options available
 - DRAM (Dynamic RAM): Dense, volatile, requires periodic refreshing

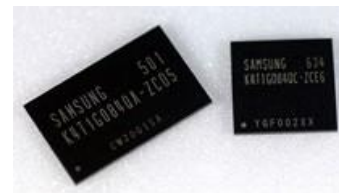

WIRED INTERFACING

Computing Interfaces

- Universal System Bus (USB)
 - Multiple data rate classes available:
 - Low-Bandwidth: 1.5 Mbps (USB v1.1)
 - Full-Bandwidth: 12 Mbps (USB v1.1)
 - Hi-Speed: 480 Mbps (USB v2.0)
 - SuperSpeed: 5.0 Gbps (USB v3.0)
 - SuperSpeed+: 10 Gbps (USB v3.1)
 - Some common protocol implementations:
 - Host: Device acts as the master for other USB devices (requires implementation of 1+ host controllers)
 - Client: Device acts as a slave device (various profiles available)
 - USB On-The-Go (OTG): Devices take turns acting as host and slave



WIRED INTERFACING

Computing Interfaces 2

- USB cont.
 - USB connector options:
 - Standard: larger connectors used on laptops, desktops, tablets, etc.
 - Mini: Used in cameras, camcorders, and other small devices
 - Micro: Supercedes mini on most smartphones, etc.
 - USB Power Limits:
 - USB v1.1: 150mA@5V from port, 2A@5V from external
 - USB v2.0: 500mA@5V from port, 2A@5V from external
 - USB v3.0: 900mA@5V from port, 2A@5V from external
 - All USB devices start in low power mode; must request additional power

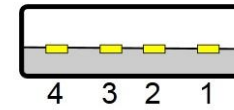

Type A

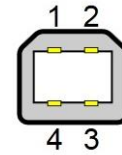

Type B

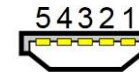

Mini-A

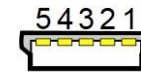

Mini-B

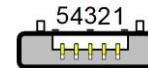

Micro-A

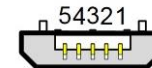

Micro-B

WIRED INTERFACING

Computing Interfaces 4

- Ethernet (IEEE 802.3):
 - Specification involved in networking devices (for more on networking devices, read up on the [OSI](#) and [TCP/IP](#) networking models)
 - Consists of the physical layer and link layer for connecting devices
 - Ethernet development generally requires external support hardware:
 - PHY Chip: Implements the physical layer functions of an Ethernet interface
 - MAC Chip: Implements data link layer functions of an Ethernet interface
 - A useful reference design for microcontroller Ethernet can be found [here](#)

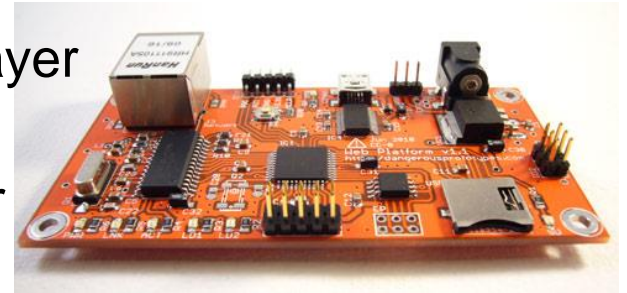

WIRED INTERFACING

Other Interfaces

- Powerline Communication (PLC) / X-10:
 - Modulate signals over existing AC power lines to send data
 - Example applications: home automation, Christmas tree light controllers
- Musical Instrument Digital Interface (MIDI):
 - Standard specifying a protocol and connectors
 - MIDI over USB is permitted
- On-Board Diagnostic System (OBD-II):
 - Required on all US motor vehicles manufactured after 1995
 - Facilitates communication with onboard vehicle computers
 - Many manufacturers implement proprietary codes (use of licensed OBD-II protocol ICs can overcome this)

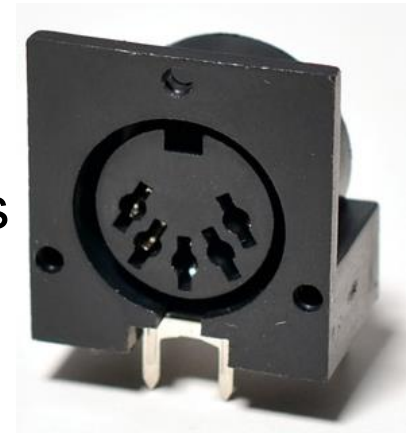

WIRELESS INTERFACING

General Computing Interfaces

- WiFi (IEEE 802.11x):
 - At the embedded hobbyist level, WiFi is generally implemented using dedicated chips and/or modules
 - NOTE: PAL2.0/3.0 has challenges with individual embedded WiFi (use of personal routers recommended)
 - Revisions of the WiFi protocol:
 - IEEE 802.11a: 54Mbps@5GHz (OFDM)
 - IEEE 802.11b: 11Mbps@2.4GHz (OFDM)
 - IEEE 802.11g: 54Mbps@2.4GHz (OFDM)
 - IEEE 802.11n: 54-600Mbps@2.4GHz or 5GHz (OFDM), Support for multiple antennae (MIMO)
 - Future Revisions: More channels, millimeter wave band support (30+ GHz), etc.



WIRELESS INTERFACING

General Computing Interfaces 2

- Bluetooth:
 - Common wireless option for interfacing to computers and mobile devices (~100 yard/m max range)
 - 2.4GHz operation (interference from WiFi, microwaves, and other 2.4GHz devices)
 - As of Bluetooth v4.0, a second Bluetooth Low-energy spec (Bluetooth LE) was introduced. Bluetooth LE is not backwards compatible with existing Bluetooth hardware

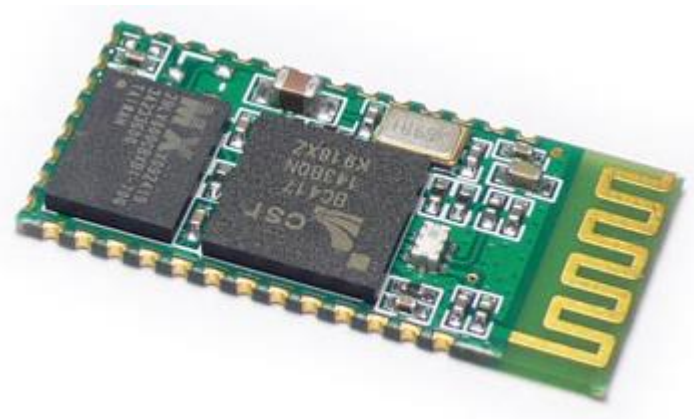

WIRELESS INTERFACING

Mobile/Cellular Interfaces

- GSM/GPRS:
 - 2nd Gen cell network protocols (900MHz, 1800MHz)
- 3G:
 - 3rd Gen cell networks (various standards; CDMA, TDMA, FDMA common protocols)
- 4G:
 - 4th Gen cellular networks (various standards; WiMax and LTE common protocols)

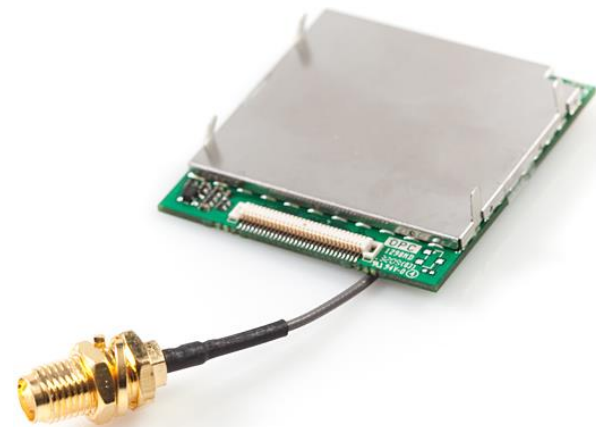
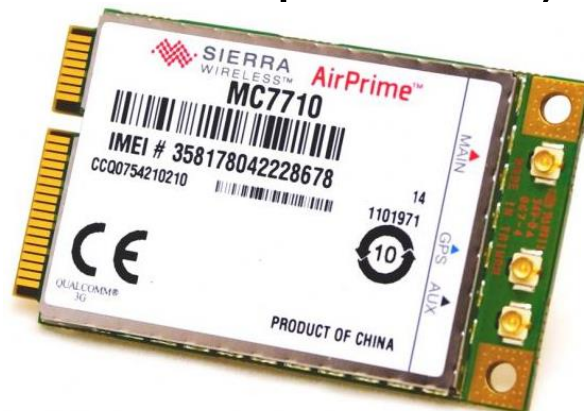

WIRELESS INTERFACING

Embedded Interfaces

- Zigbee:
 - 2.4GHz operation (incompatible w/ Bluetooth and WiFi)
 - Support for mesh networking (network nodes can be added/dropped ad hoc)
- RF:
 - Various RF modules exist at different frequencies
 - Power, and supported modes at various frequencies governed by the FCC (in USA)



WIRELESS INTERFACING

Other Interfaces

- Radio Frequency Identification (RFID):
 - Cheap, passive tags (used to ID objects)
- Near Field Communication (NFC):
 - Communicates using electrical or magnetic fields (but not radio waves)
 - Capable of communicating through conductors
 - Secure, private (more difficult to intercept than RF)
- Wireless Power Transmission:
 - Used in some charging applications

