

# THE INCREDIBLE HUD

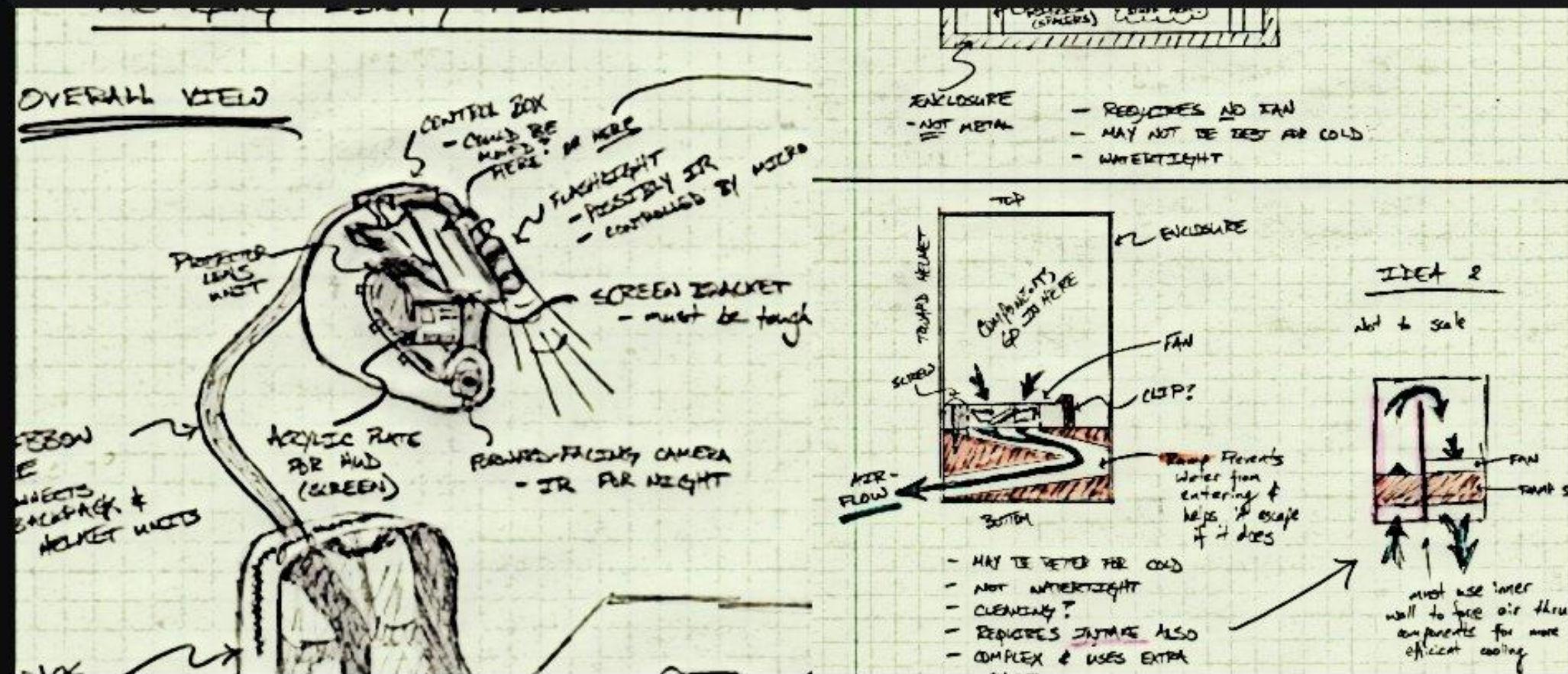

# PSSCs

- An ability to display critical system information via a heads-up-display (HUD)
- An ability to measure telemetry information (speed, acceleration, temperature, and GPS) and store it to flash memory.
- An ability to maintain portability through the use of a rechargeable battery system
- An ability to enable/disable important features within the display (full information, minimal, on/off).
- An ability to plot recorded GPS data on a map while overlaying telemetry information on a computer.

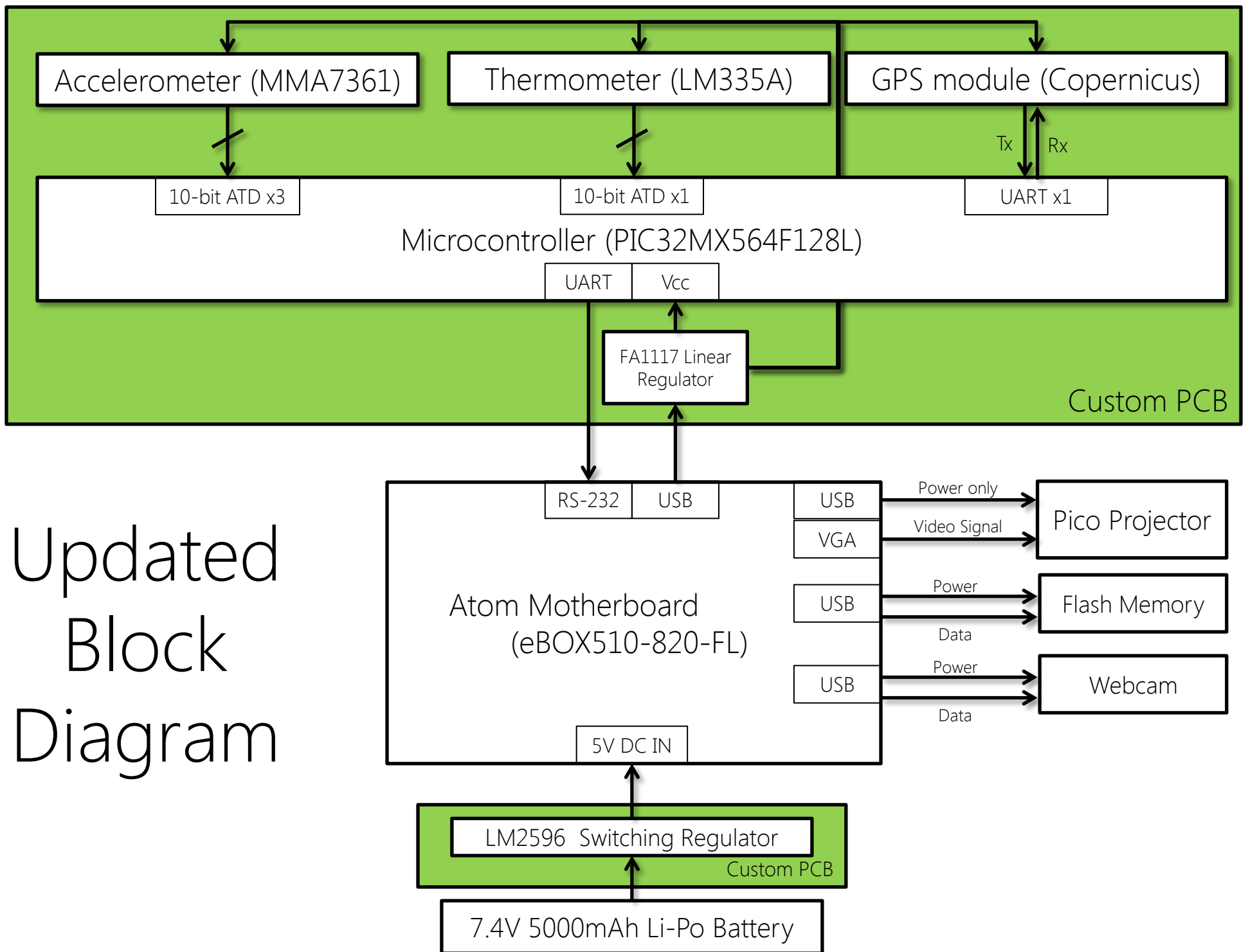

# Backpack Unit PCB

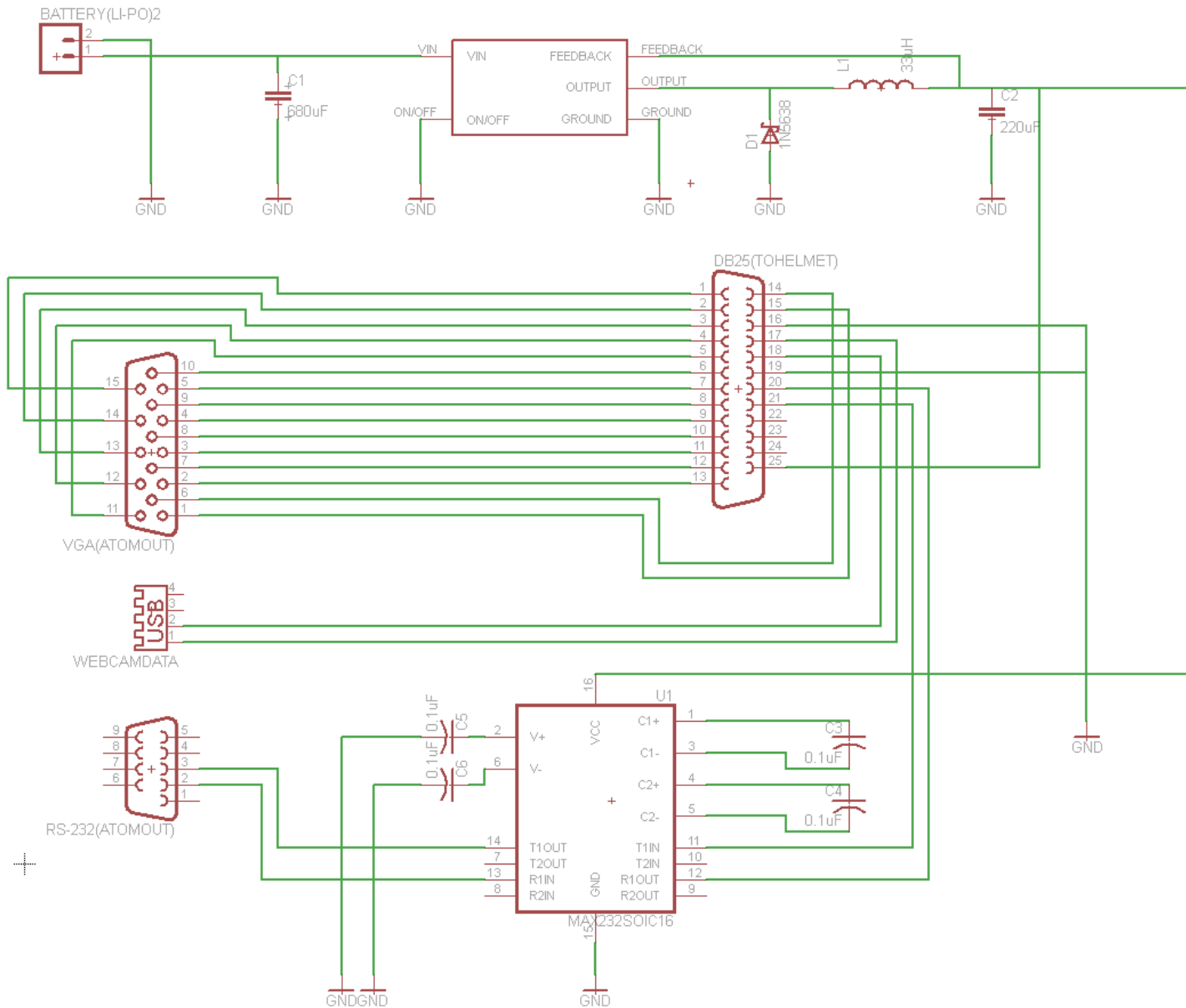

# Microcontroller PCB (On-helmet)

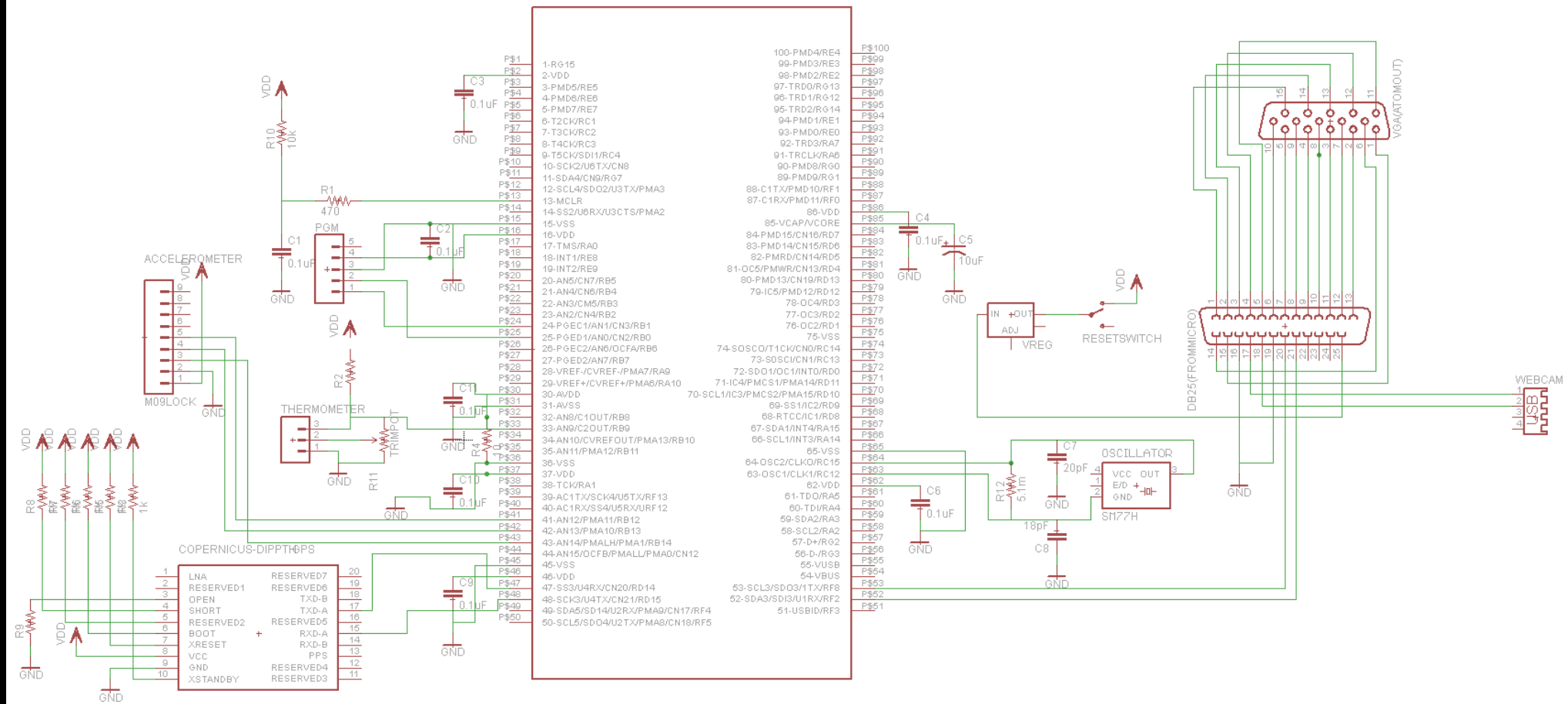

# Microcontroller PCB (Zoom-in)

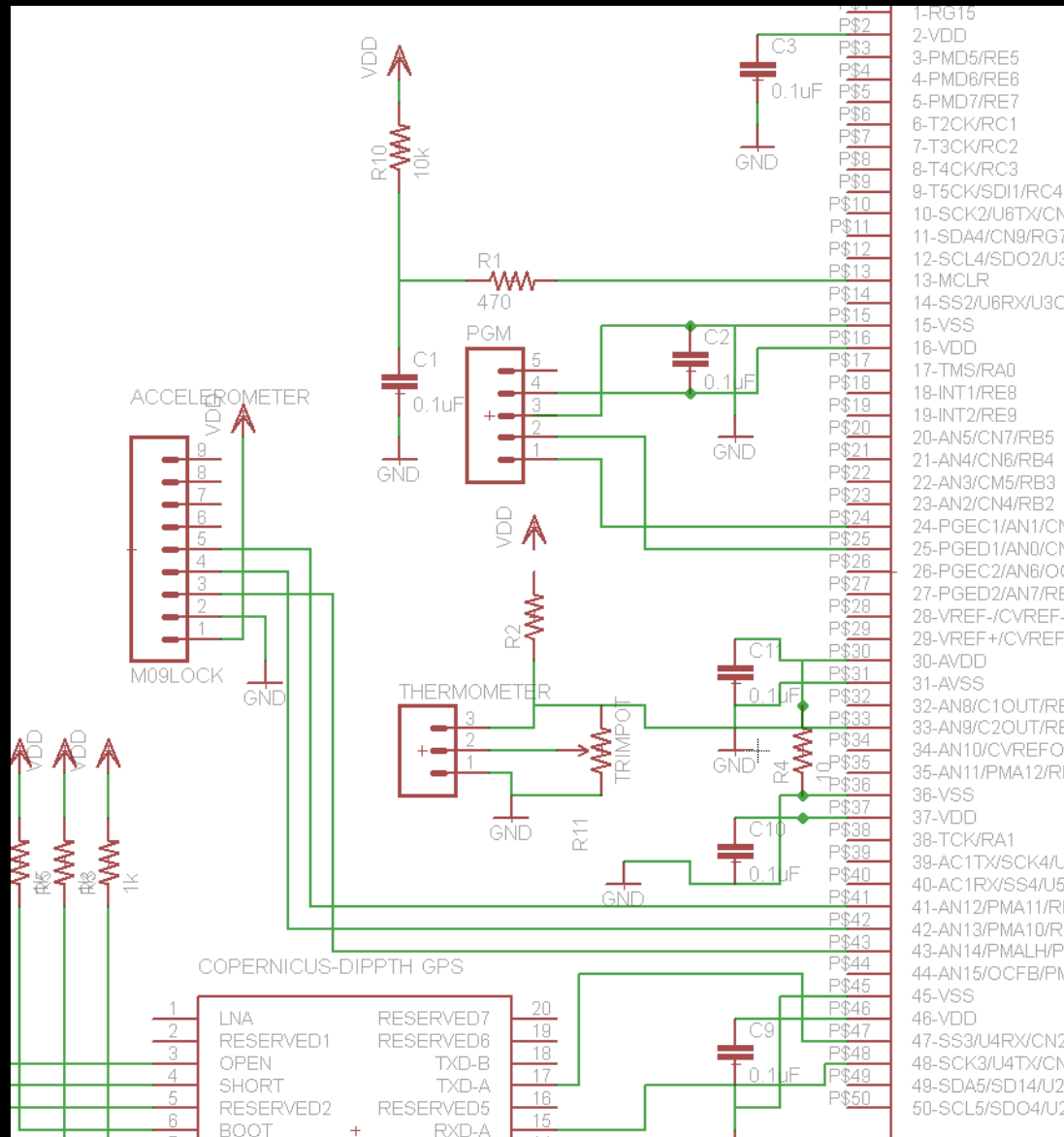

# Microcontroller PCB (Zoom-in)

