



Audio Engineering Society Convention Paper 5322

Presented at the 110th Convention
2001 May 12–15 Amsterdam, The Netherlands

This convention paper has been reproduced from the author's advance manuscript, without editing, corrections, or consideration by the Review Board. The AES takes no responsibility for the contents. Additional papers may be obtained by sending request and remittance to Audio Engineering Society, 60 East 42nd Street, New York, New York 10165-2520, USA; also see www.aes.org. All rights reserved. Reproduction of this paper, or any portion thereof, is not permitted without direct permission from the Journal of the Audio Engineering Society.

ELECTRONICALLY CONTROLLED LOUDSPEAKER ARRAYS WITHOUT SIDE LOBES

Johan van der Werff, johanvanderwerff@cs.com.
Peutz & Associés

Postbus 66, NL-6585 ZH Mook, The Netherlands, mook@peutz.nl.

ABSTRACT

It is possible to arrange loudspeakers in such a way that only one lobe emits from the array. This lobe can have an arbitrary beam width and to a certain extent an arbitrary beam shape. Because of this control over the beam, narrow beam widths can be made where wave fronts travel coherently 200 meters or more. It is possible now to cover an area below and in front of the array from almost zero to 200 meters with even direct-sound distribution of ± 3 dB, where the frequency response is only dependant on the transducer used and the air absorption. This eliminates the coloration-effects due to side or grating lobes.

INTRODUCTION

There are basically two kinds of loudspeaker arrays. The thing they have in common is that they visually appear to be one unit or construction. The difference is that the one is designed to behave as individual units, where every interference is more or less detrimental and the other is designed to behave as one unit based on the existence of interference between the units. Controlled interference is only possible when the radiating surfaces of the adjacent units in the same frequency band are less than $\frac{1}{2}$ apart. In that case the directional characteristic of these units is almost the same as one unit with the combined surface area. If the units are more than $\frac{1}{2}$ apart the directional characteristics will be very irregular. At certain angles and with certain frequencies all the pressures add up in-phase and amplify each other and at other angles and/or other frequencies the pressures add up out of phase and cancel each other. With most angles and frequencies something in between happens. The in-phase addition is called constructive interference and the out of phase addition is called destructive interference.

With a line-array, 4" speakers can be mounted so closely together that the array behaves as one loudspeaker for frequencies lower than 4000 Hz. Small loudspeakers will radiate almost omni-directional

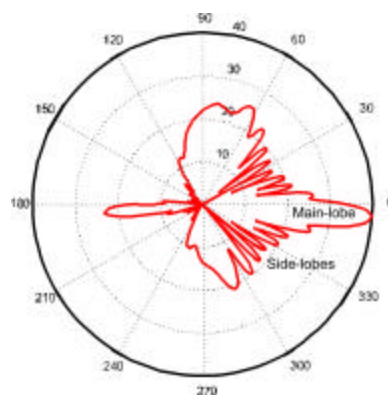

Figure 1: Main and side-lobes of an array sound level ratio. Off-axis the sources will drop gradually out of phase creating a more or less well defined lobe. By changing the signal timing to each loudspeaker the lobe can be steered to a certain direction [1]. The operation is more or less the synchronization of the loudspeaker signals at a certain angle of the array. On both sides of this lobe side-

and the interference between the units will be at maximum. For the direct sound on-axis, all the loudspeakers are exactly in phase and add up with 6 dB per doubling of sources. The reverberant sound however will add up with 3 dB per doubling of sources. So there is a net improvement in the direct to reverberant

lobes emerge with a lesser level than the main lobe. The number of side-lobes and the angle of the maximum level is dependent on the frequency and the length of the array (see figure 1).

At higher frequencies the distance between the loudspeakers is more than $\frac{1}{2} \lambda$. If the distance between the loudspeakers is the same, well-defined grating-lobes will emerge at angles between 30 and 60 degree. A funny coincidence is that the noun 'grating' says something about the reason why these lobes emerge and the adjective something about the impression it makes when listening in a spot where a grating-lobe hits the listening plane. Most practical not suppressed grating-lobes are the cause of a narrow band amplification of 10 to 15 dB around 3 to 4 kHz. Side-lobes sound much milder, like comb filtering, usually in the vicinity of the array. For speech this is usually acceptable, but for music like opera for instance this is less acceptable because the sound is the worst in the front rows, the most expensive places.

The rest of this paper will exist of two independent paragraphs,

1. The shaping of lobes without side-lobes
2. The acoustic interest of arrays with a well controlled narrow beam width.

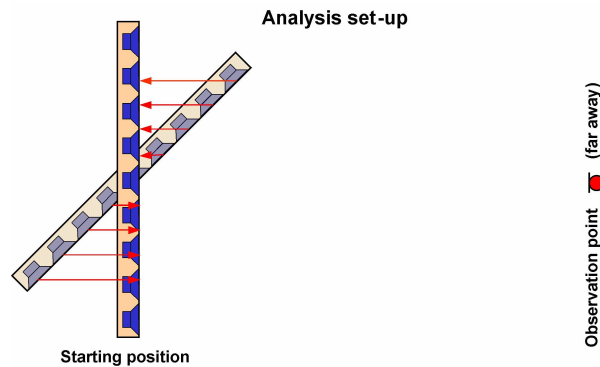

Figure 2: Analyses setup for the cause of side-lobes

1. THE SHAPING OF LOBES WITHOUT SIDE- OR GRATING LOBES

To get an understanding of the reasons why side-lobes emerge, an analysis is made with the setup pictured in figure 2. From the observation point at a large distance, the behavior of the column can be described by looking at the way the individual sources add up at every angle. This is described in the figures 3a, b, c, and d at

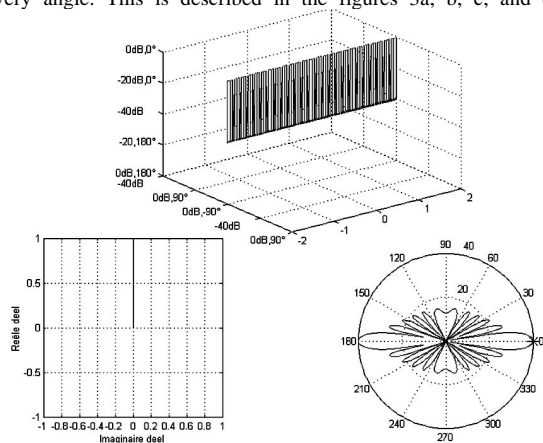

Figure 3a: Vector display of an array at 0° rotation

respectively 0°, 5°, 10° and 15° rotation of the column. Every figure has 3 sub-figures. The topmost is a 3-dimensional graph of the level and the relative phase of each source. There are 5 omni-directional sources defined per loudspeaker cone and a space in between. Each source is a vector on a central axis where the length of the vector defines the magnitude and the angle with the zenith defines the phase angle. The magnitude range at the y- and z-axis is 40 dB. The length of the column is on the x-axis and extends + and - 2 meter from the middle. The lower left graph shows a 2-dimensional view of the same data through the y-z window. The right-left graph shows the complete 360° polar of the setup and a * marks the zero-dimension which is the vector-sum and the output of the column at that the shown angle.

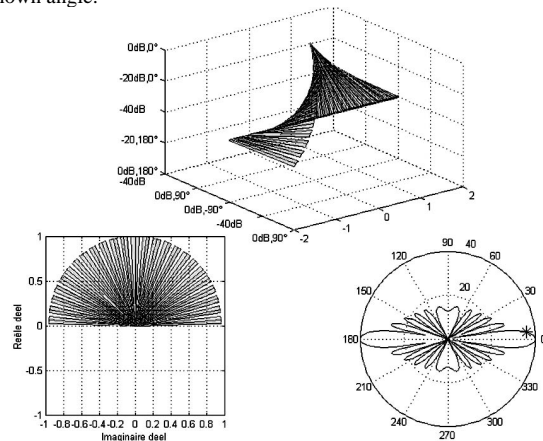

Figure 3b: as figure 3a but at 5° rotation of the array

In figure 3a, the observation angle is 0° and all sources have the same distance to the observation point and are therefore in-phase. The output level of the column is at maximum. In 3b, at 5° the distances are not equal anymore and therefore some phase-shift occurs and the output level is less, approx. -5dB.

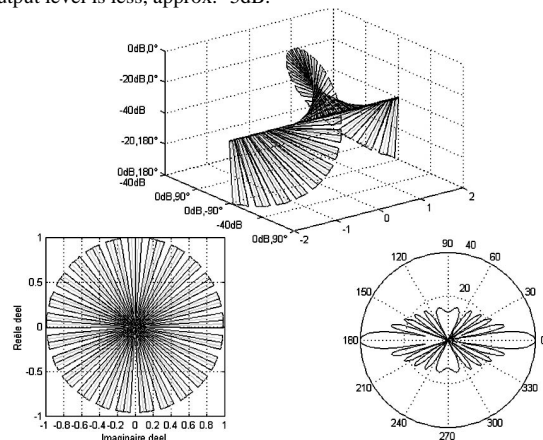

Figure 3c: as figure 3a but at 10° rotation of the array

In 3c at 10° the phase-shift between the outer sources is now 360°. All vectors have now an opposite vector and are canceling each other. The output of the column is theoretical -∞ dB and with practical loudspeakers less than -40 dB. In 3d, at 15° the phase-shift between the outer sources is now 540°, this means that 2/3 of the vectors cancel each other and the rest add up to the first side-lobe at approx. -15dB. At 20° the phase-shift is 720° and the vector sum is -∞ dB again and at 25° 1/5 of the vectors add up to the second lobe etc. etc.

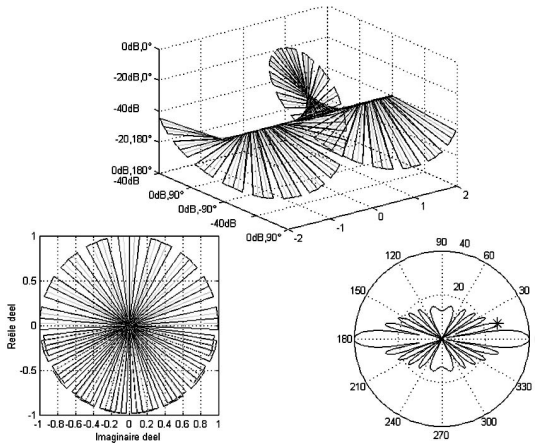

Figure 3d: As figure 3a but at 15° rotation of the array

The figures are valid for one frequency only and for a column with a certain length. At higher frequencies and/or longer array lengths the side-lobes will grow denser and change position in the polar response. If the array is not observed with a single tone but with octave noise, then due to the averaging effect the side-lobes will be less visible. Because the sources in his model are defined as omnidirectional, the lobes will be symmetrical around the zenith (back-lobe is the same as the front-lobe). Practical loudspeakers will have a significant directionality, especially at the higher frequencies, so the back-lobe is only there for the lower frequencies. It should be remembered that these figures are valid in the far field (distance >5*length). Practical arrays are also listened to in the near field. This makes the side-lobes sound less disturbing, but the mounting height is critical for a good intelligibility.

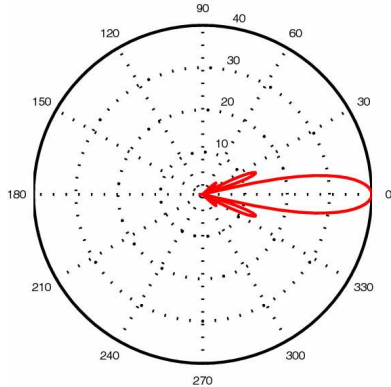

Figure 4: Array with linear tapering

where from the middle to the extremes the magnitude of the vectors (the signal amplitude to the speakers) decrease to zero. The resulting response is shown in figure 4. The side-lobes are not gone but are suppressed in level at the expense of a wider main lobe.

A better method of tapering is shown in figures 5a and 5b. This eliminates the side-lobes completely. When the angle with the main axis increases the sum-vector will decrease progressively. Even when the polar response would be shown on an 120 dB scale it would still show no signs of side-lobes. To get a coverage angle that is constant with frequency the tapering should be adjusted accordingly.

Grating-lobes emerge when the distance between the sources is too large. With practical loudspeakers the cones cannot be made to fit closer than the basket allows. At higher frequencies (> 2500 Hz) the inter cone distance is significant compared to the wavelength. In figure 6a and 6b this situation is shown. In these figures the

To eliminate the side-lobes it is of course not possible to prevent the turning of the vectors, this is inherent to listening under an angle other than the main axis. It is possible to choose the magnitude of the vectors in such a way that opposing vectors never cancel each other. A first attempt is made in [2]. Menges uses linear tapering,

frequency is higher and one loudspeaker is modeled with 4 sources

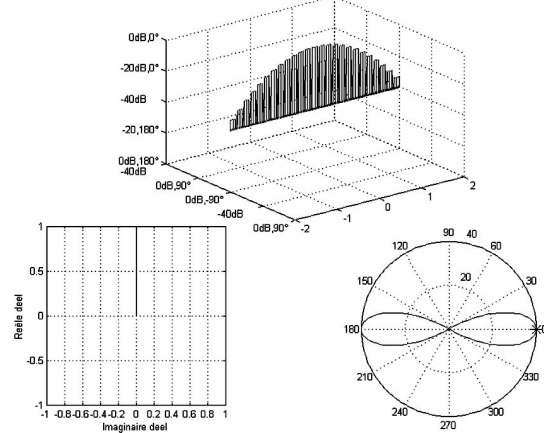

Figure 5a: Vector display of array with critical tapering at 0° rot.

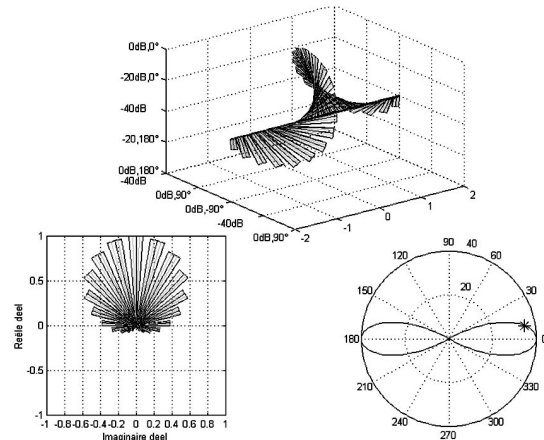

Figure 5b: As figure 5a but at 10° rotation of the array

and 2 spaces. The side-lobes have been eliminated, only the grating-lobes are visible. At an angle of 45° the distance between the loudspeaker centers is one wavelength and hence there is a phase shift of 360 degrees, but not only in the centers, also at the edges and every point in between. In the lower left diagram it is shown that the two spaces are the two missing vectors that would have prevented the emerging of the grating-lobe

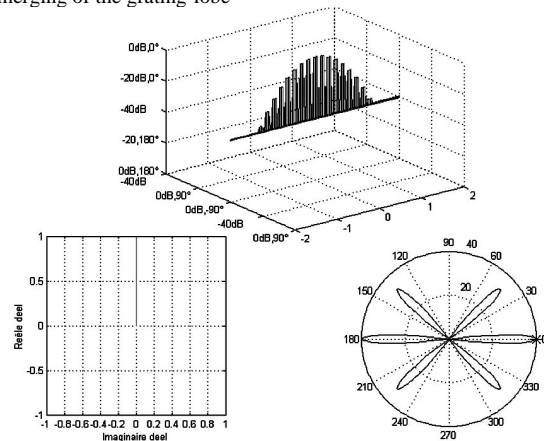

Figure 6a: As figure 5a but with smaller loudspeaker cones and at higher frequency.

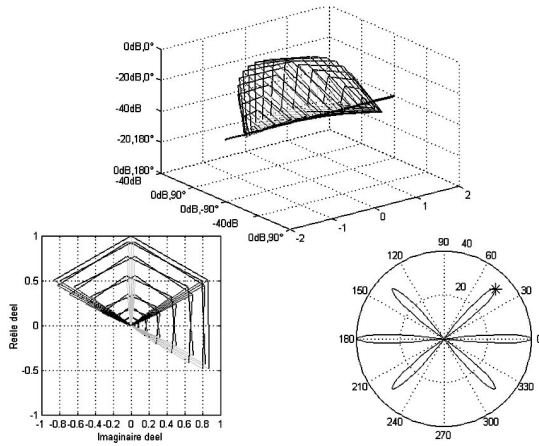

Figure 6b: As figure 6a but at 45° rotation of the array

It is not necessary that the vectors start from the 0° position. With complex control it is possible, within reasonable limits, to construct almost any lobe shape. In figure 7a and 7b a lobe is shown suitable for a dome stadium with two level stands, a central stage and also public on the floor. The array is suspended above the stage with its center at the balustrade level. The level at the stage, the dome and the balustrade are less to avoid ringing and unnecessary reflections. The floor and both stand levels are covered evenly.

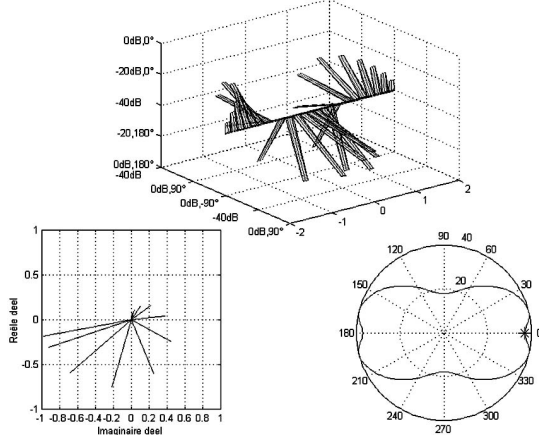

Figure 7a: Array with complex control at 0° rotation

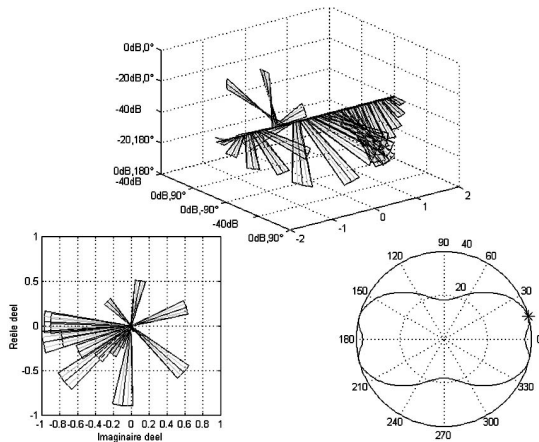

Figure 7b: As figure 7a but at 15° rotation of the array

A very useful lobe is the one that can be made with an asymmetric array. First because the acoustical center is low so a high Q lobe is possible where the sound can 'skim' over the heads of the listeners (see par. 2). Second because at the same time it is possible to shape the lobe in such a way that an even coverage can be reached with a flat floor and a riser at the end. In figure 8a and 8b this lobe is shown. Remarkable is that when omni-directional speakers are used the level reduction straight under the column is 25 dB. This means that with a distance ratio of height (above ear level) to the farthest listener, of 1:18 an even coverage can be made with a radius of the farthest distance.

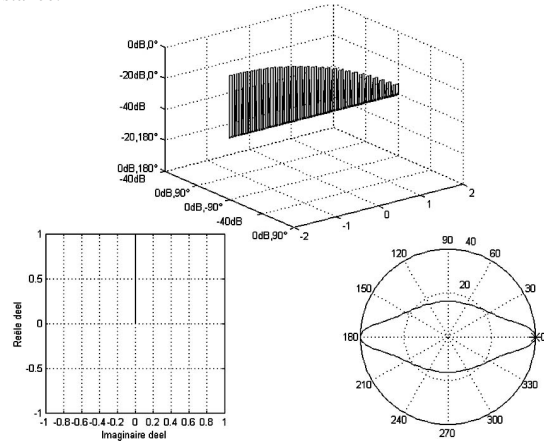

Figure 8a: Array with asymmetrical tapering at 0° rotation

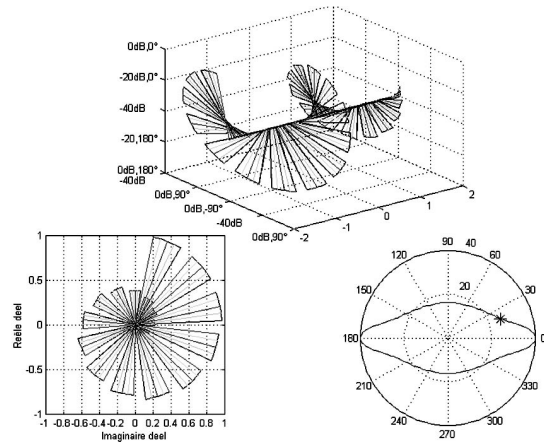

Figure 8b: As figure 8a but at 20° rotation

Figure 9a and b show a 3-dimensional and a 2-dimensional representation of a practical symmetrical column loudspeaker. This one is used in 1998 in the Amsterdam ArenA at the Margriet 60 concert. At the lowest frequencies there are some mild side-lobes due to a compromise between length and coverage angle. The side-lobe level is at approx. -35 dB at 300 Hz and lower. The side-lobes at the high frequencies are a property of the loudspeaker used. Because at low frequencies the 6" loudspeaker used will grow towards omni-directional, a back-lobe can be seen in the 3-dimensional graph.

Figure 10 shows the same for the accompanying asymmetrical loudspeaker. The evenness in sound level in the covered area is the most spectacular property. At ear level from a few meters to 200 meter within + and - 3 dB. The calculated value of the spatial decrease is shown in figure 11. The principle is equally applicable for higher frequencies. In figure 12 data is shown that is measured at 10, 20, 40, 80, 160 and 300 meters distance from a high frequency

column with a coverage angle of $180^\circ \times 7^\circ$. The column is driven

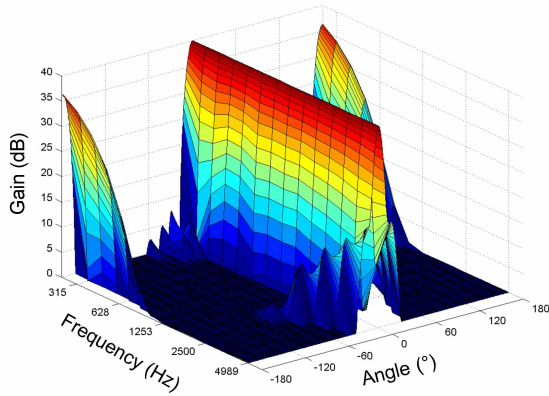

Figure 9a: 3D polar plot of symmetrical side-lobe free array

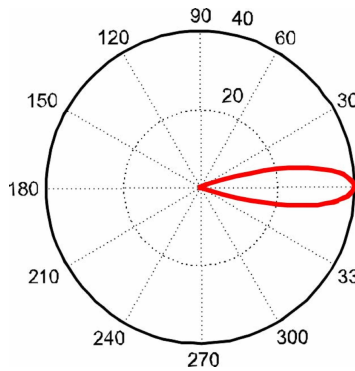

Figure 9b: 2D polar plot of the same array at 1000 Hz tone.

with low frequency limited pink noise. It is shown that this line-array does almost not decrease in level up to 160 meters. At 160 meters the bending of the lobe by the wind of approx. 2 Beaufort is noticeable in the equivalent (Leq) values. At the maximum values (Lmax) seen in figure 13 it is not yet noticeable.

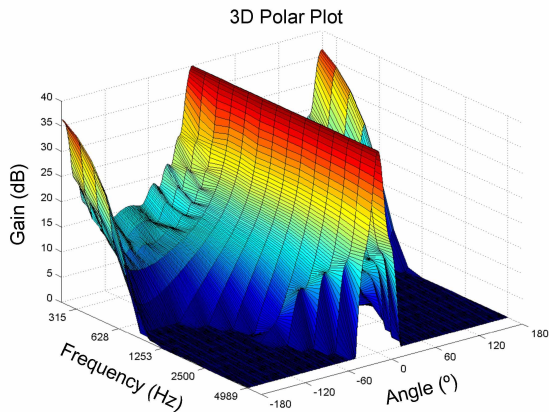

Figure 10a: 3D polar plot of asymmetrical side-lobe free array

In principle it should be equally possible to filter the signals acoustically, after it has left the loudspeaker as with a DSP before it reaches the loudspeaker. And indeed a material could be found that had suitable acoustic filter properties. A number of layers, different for every pair of speakers, is placed before the speakers and the speaker units are connected in such a way that a coarse type of tapering is present. Beam steering as with DSP controlled arrays was of course not possible, but the material could be arranged in such a way that the column has a more or less downwards pointed cardioid directional characteristic, perpendicular to the directional

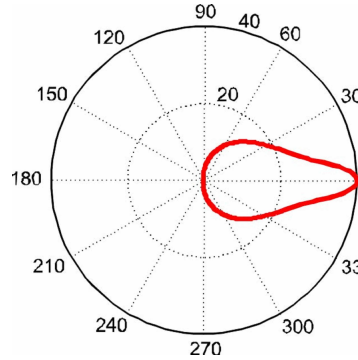

Figure 10b: 2D polar plot at 100 Hz tone frequencies. Side-lobes are neither noticeable nor audible nor visible in the graph. The mild grating lobe is due to the loudspeakers and the coarseness of the acoustic control.

characteristics of the loudspeakers. The array is totally passive. In figure 14 a measured polar diagram is shown of such a loudspeaker. Shown are the third octave averaged values with octave intervals. The vertical coverage angle is almost constant with frequency, up to the point where the 800 mm column is too short to control the low

Asymmetrical array, 6 meter long @ 1000Hz (tone), vertical coverage angle: 7° , height: 4 meter

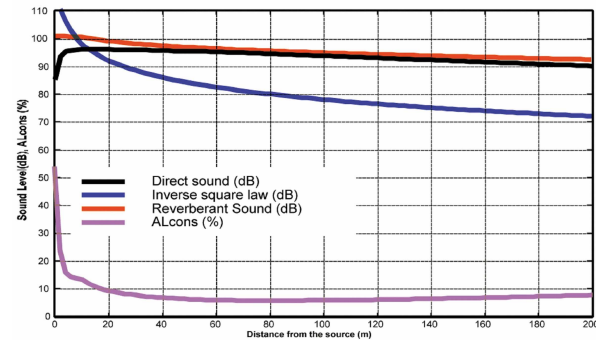

Figure 11: Calculated spatial decrease of asymmetrical array

Spatial decrease H.F. $180^\circ \times 7^\circ$ line array (no equalisation)

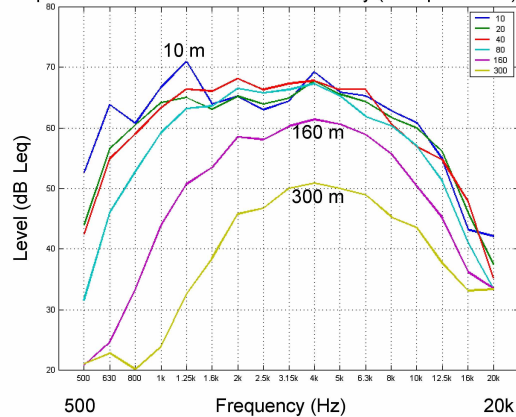

Figure 12: Measured sound levels (Leq) of an H.F. array.

The column can be placed straight on or in the wall, delivering a constant sound quality from the first row to approx. 15 to 20 meters (estimated). Horizontally the coverage is almost 180° . The wall on which the column is mounted will mirror the back-lobe to the front. The cardioid characteristic will prevent that a large portion of the sound is radiated upward and thus reduces the reverberant sound level.

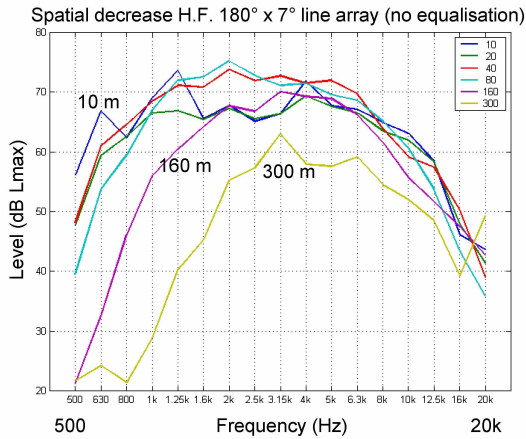

Figure 13: Measured sound levels (Lmax) of an H.F. array.

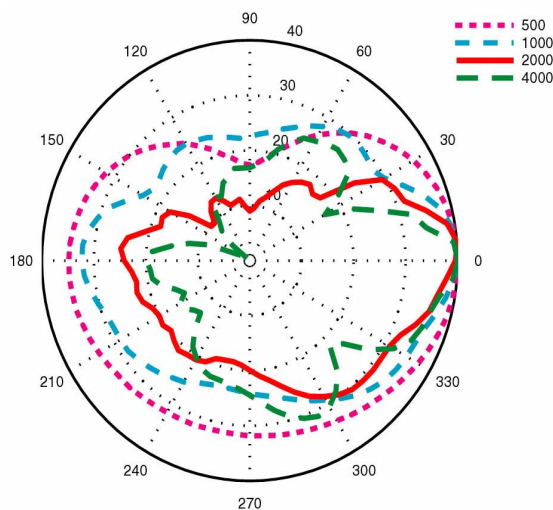

Figure 14: Measured polar responses of passive array (1/3oct)

2. THE ACOUSTIC RELEVANCE OF ARRAYS WITH A WELL CONTROLLED NARROW BEAM WIDTH

Peutz does not design loudspeakers from the viewpoint of the loudspeaker, but from the viewpoint (or rather the listening point) of the listener. The loudspeaker is just a means to deliver quality sound at the position of the listener. This listener has paid for his chair and cannot easily move somewhere else and expects rightly so a good sound quality. This sound quality will be optimal if the direct to reverberant ratio is optimal. The direct to reverberant ratio is optimal if the direct sound is evenly distributed. If at a certain spot the direct sound is higher than strictly necessary, more energy is added to the reverberant field after reflection than is necessary. This is detrimental for the sound quality at other places.

The reverberant sound level will decrease only slightly with the distance to the source. If the direct sound level follows the same declination the direct to reverberant ratio and therefore the sound impression will be the same everywhere. For speech intelligibility the usual target for the reverberant sound level is as low as possible. The level of the reverberant sound in a given room is defined by the directivity of the source, expressed in the "Q factor" or the Directivity Index (DI = 10logQ). If the directivity goes up (this means that the energy is distributed over a smaller spatial angle), the reverberant sound level will drop. Another aspect of sound quality is

coloration. If this is due to the on-axis frequency response of the loudspeaker it will be equalisable, but if it is caused by comb filtering due to multiple sources it will not be equalisable because it will be different for every seat. This is more important for music than for speech. Especially for music purposes care should be taken to archive the required directivity while avoiding side-lobes and other sources of comb filtering.

The required directivity of a loudspeaker can be found by calculating the angular sound level decrease from a number of relevant listening positions to the loudspeaker position. Inverting these values and entering them in a polar plot will yield the wanted directivity of the loudspeaker (cluster). If a loudspeaker can be found that has exactly the wanted angular distribution than the direct sound level will be the same everywhere and the speech intelligibility will be optimal but only from that loudspeaker position. At higher loudspeaker positions a larger coverage angle is necessary than from a lower loudspeaker positions. The lower the loudspeaker position, the smaller the needed coverage angle, the higher the possible Q of the loudspeaker(set), the lower the reverberant sound level and the better the speech intelligibility.

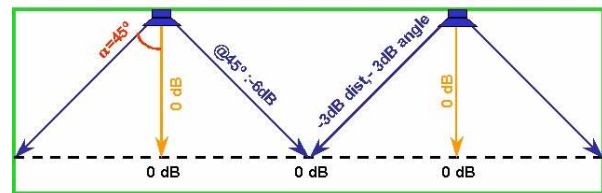

Figure 15: Typical ceiling speaker design

That this is a significant effect can be demonstrated by three exemplary loudspeaker positions. Three typical loudspeaker designs are placed in a hall of 50 x 50 meters, 12 meters high. The designs are: ceiling speakers, shown in figure 15, horn speakers, shown in figure 16 and array speakers, shown in figure 17. Whether the loudspeakers in fig. 15 and 16 are really ceiling or horn speakers is not significant. If array speakers would be placed at the same positions and with the same angular distribution, the effective Q would be the same and hence also the speech intelligibility.

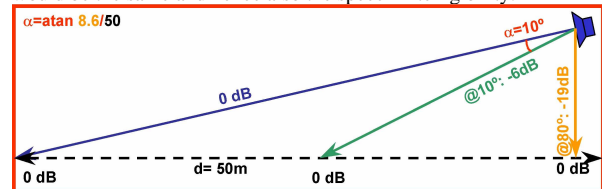

Figure 16: Typical Horn loudspeaker design

Ideal ceiling speakers have a coverage angle of 90° x 90° and have a Q of 6. The Directivity Index (DI) is 10 log Q and is equal to 7.8 dB. To cover the floor area completely 8 loudspeakers are necessary. A listener will receive direct sound from one loudspeaker but reverberant sound from 8 loudspeakers. The effective Q of the system will therefore be 6/8 = 0.75 and the system DI will be -1,2 dB.

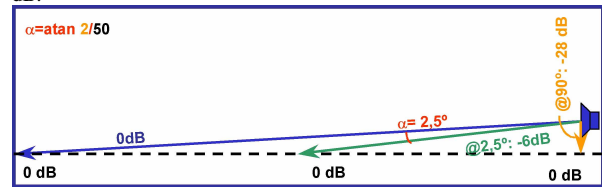

Figure 17: Typical Array loudspeaker design.

A system with horn loudspeakers built with units with the highest directivity, can be made with a 40° x 20° unit @ 0 dB for the far end and a 60° x 40° unit @ -2dB for straight underneath. This

combination can cover a rectangle of 50m x 18m evenly with direct sound. The Q of the set is 25 and the DI =14 dB. To cover the entire room 3 sets are necessary. The resulting system Q is $25/3 = 8$ and the effective DI will be 9. This is 10 dB better than the ceiling speakers

With an array loudspeaker low above the listening plane a vertical coverage angle is necessary of approx. 5° . The optimum horizontal coverage angle will be 180° . These kinds of coverage angles are only possible with long, narrow loudspeakers, so array loudspeakers are the obvious choice. If a loudspeaker like this is aimed at the listening plane in the conventional way the effective coverage angle is about 60° because at the sides the lobe will be at the same height as the loudspeaker, so well above the listening plane. A more effective way is to aim the array electronically by means of delaying the signal to the loudspeaker units, increasing linearly from the top down. Even if the array hangs straight, the loudspeaker signals are "synchronized" and the array seems to be aimed downwards, not only at the front but also at both sides and the back [3]. The shape of the lobe is not a (part of a) disk anymore, but a (part of a) cone. The effective Q of such a system is 72 and the DI 18,6 dB. It is possible to cover the whole area with one unit. So the system DI stays about 18,6 dB, about 10 dB better than the horn system.

Based on this example it is possible to understand that with choosing the right (array)loudspeaker and the right mounting height it is possible to reduce the reverberant sound level and improve the direct to reverberant level by 20 dB compared to ceiling speakers. A remark can be made that in situations where arrays are applicable the benefit will not only be in better intelligibility, but also in the reduction of the cost for wiring and emergency power supply.

[1] Harry F. Olson: Acoustical Engineering, D. van Nostrand Company, Inc; LCCC# 57-8143 par. 2.6, p 37 (Why is this book not reprinted, it is still a book very worthwhile having!)

[2] Karl Mengus: Akustische Zeitung, Vol. 6, No. 2, p90, 1941. (Quote in [1])

[3] Johan van der Werff: Design and Implementation of a Sound Column with Exceptional Properties, preprint 3835, 96th Convention 1994, Amsterdam.