



PURDUE
UNIVERSITY®

Interpretable Anomaly Detection in Chemical Processes Using Large Language Models

Can Li
Assistant Professor
Davidson School of Chemical Engineering

Recent Advances



- Huge success in the past decade.



- Mainly due to the advance in hardware and the abundance of data



Cray 2 supercomputer
(1985)
1.9GFlops



40.8GFlops

Credit: Prof. Venkat Venkatasubramanian

What can LLMs do

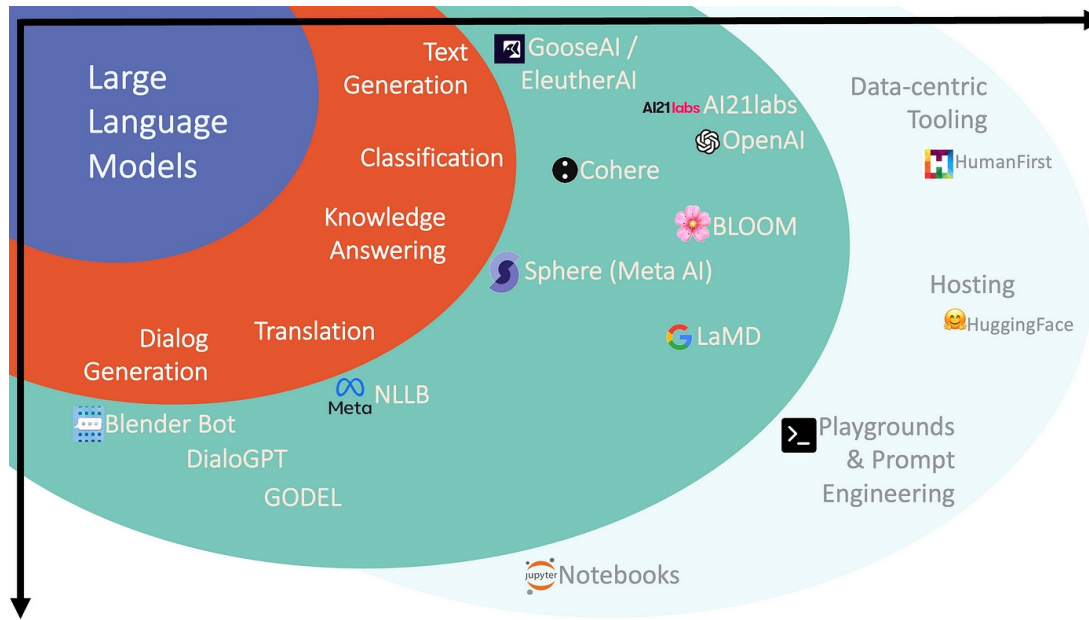

Perhaps, you have used ChatGPT for

- Correcting grammar
- Answering the homework problems
- Drafting emails and letters

Github Copilot

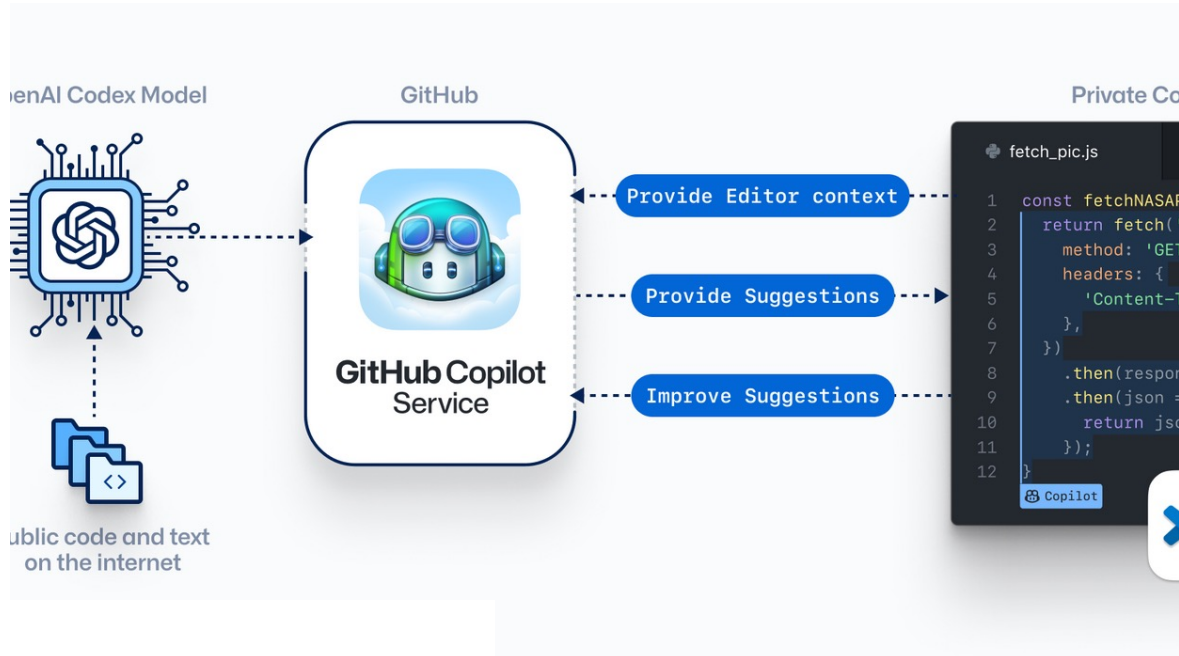

 **DeepLearning.AI**

Build a chatbot/website in seconds

SHORT COURSE

ChatGPT Prompt Engineering for Developers



You

what is Process Hazard Analysis



ChatGPT

Process Hazard Analysis (PHA) is a thorough, systematic approach for identifying, evaluating, and controlling the risks of hazardous chemical releases that could occur as a result of failures in processes, procedures, or equipment. It is an essential element of the safety management systems in chemical processing and related industries, mandated by regulations such as the United States Occupational Safety and Health Administration's (OSHA) Process Safety Management (PSM) regulation.

The main goals of a PHA are:

1. **Identify Potential Hazards:** This includes chemical exposures, fires, explosions, and releases of toxic or flammable chemicals that could result in harm to people, the environment, or the facility.
2. **Assessing the Severity of Potential Accidents:** Evaluating the potential impacts and the severity of the consequences if a hazardous event were to occur.
3. **Determining the Likelihood of Hazards Occurring:** Analyzing the probability of failure

However, it may hallucinate!

Qualitative task

A large language model interprets the results of the mathematical model and answers qualitative questions.

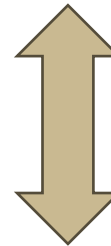

Quantitative task

Experts implement the sophisticated mathematical and physics-based models

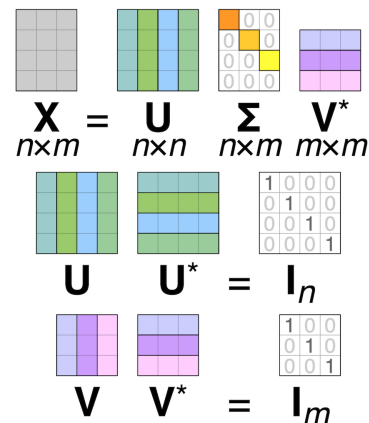

The diagram shows the decomposition of a matrix X into three matrices: U , Σ , and V^* . X is a 4x4 grid. U is a 4x4 grid with columns colored green, blue, green, and green. Σ is a 4x4 grid with diagonal elements colored orange, yellow, and purple. V^* is a 4x4 grid with columns colored purple, purple, purple, and purple. Below the matrices, the equation $X = U \Sigma V^*$ is written with dimensions $n \times m$, $n \times n$, $n \times m$, and $m \times m$ respectively. Below this, two equations are shown: $U U^* = I_n$ and $V V^* = I_m$, where I_n and I_m are identity matrices of size n and m respectively. The identity matrices are shown as 4x4 grids with 1s on the diagonal.

$$X = U \Sigma V^*$$
$$U U^* = I_n$$
$$V V^* = I_m$$

Combine Language Models with Machine Learning Models for Process Monitoring

- Fault **Detection**: Detect if a fault has occurred
- Fault **Identification**: Identify the variables most relevant to the fault
- Fault **Diagnosis** (or Classification): Diagnose the root cause of the fault

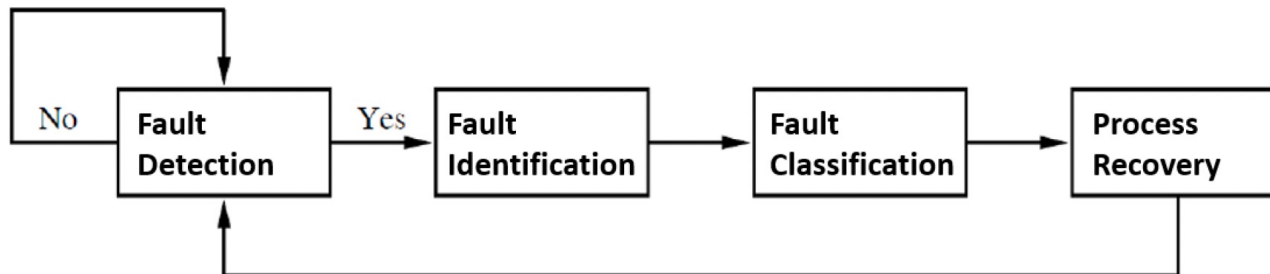

Tennessee Eastman Process



- TEP is an open-source simulator written in Fortran that resembles a real chemical process by Eastman
- Time series data can be collected from over 40 sensors that measure the state variables.
- Task: From measured state variables, perform fault detection using ML/AI

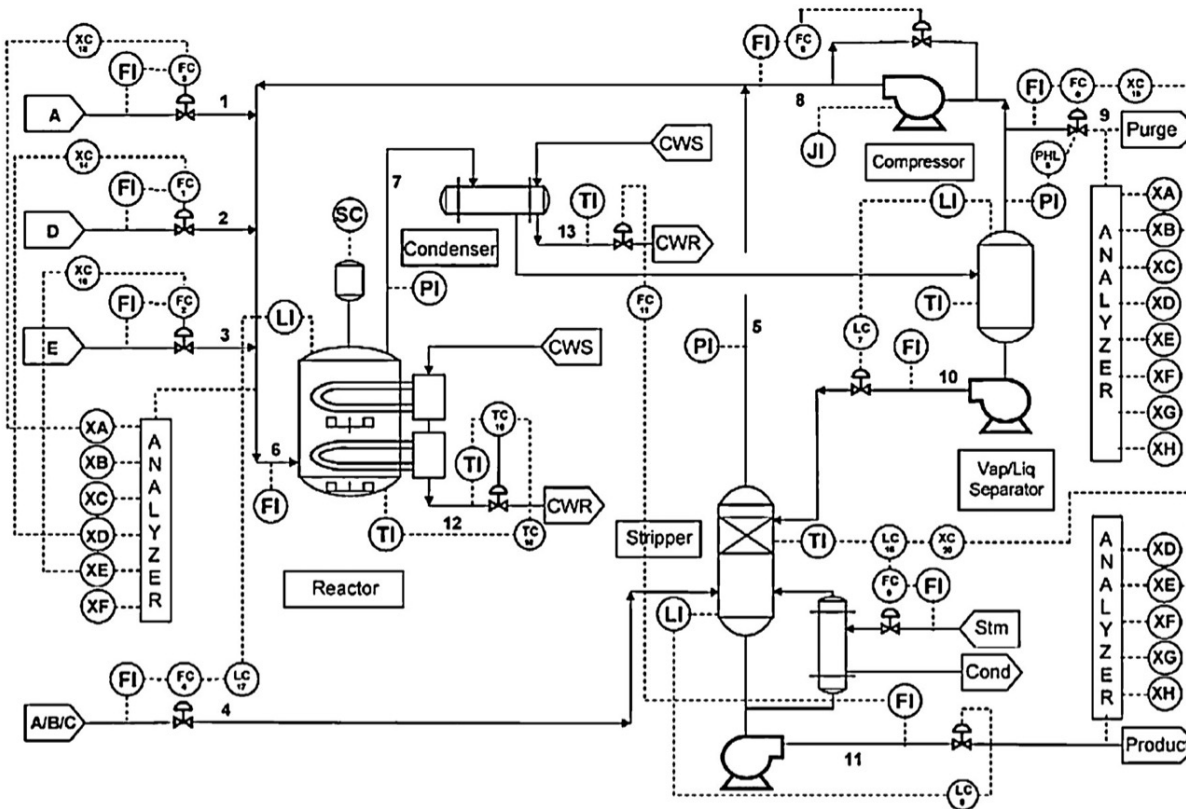

Examples of State Variables with Sensor Data



- Examples include feed flow rates, temperatures, pressures

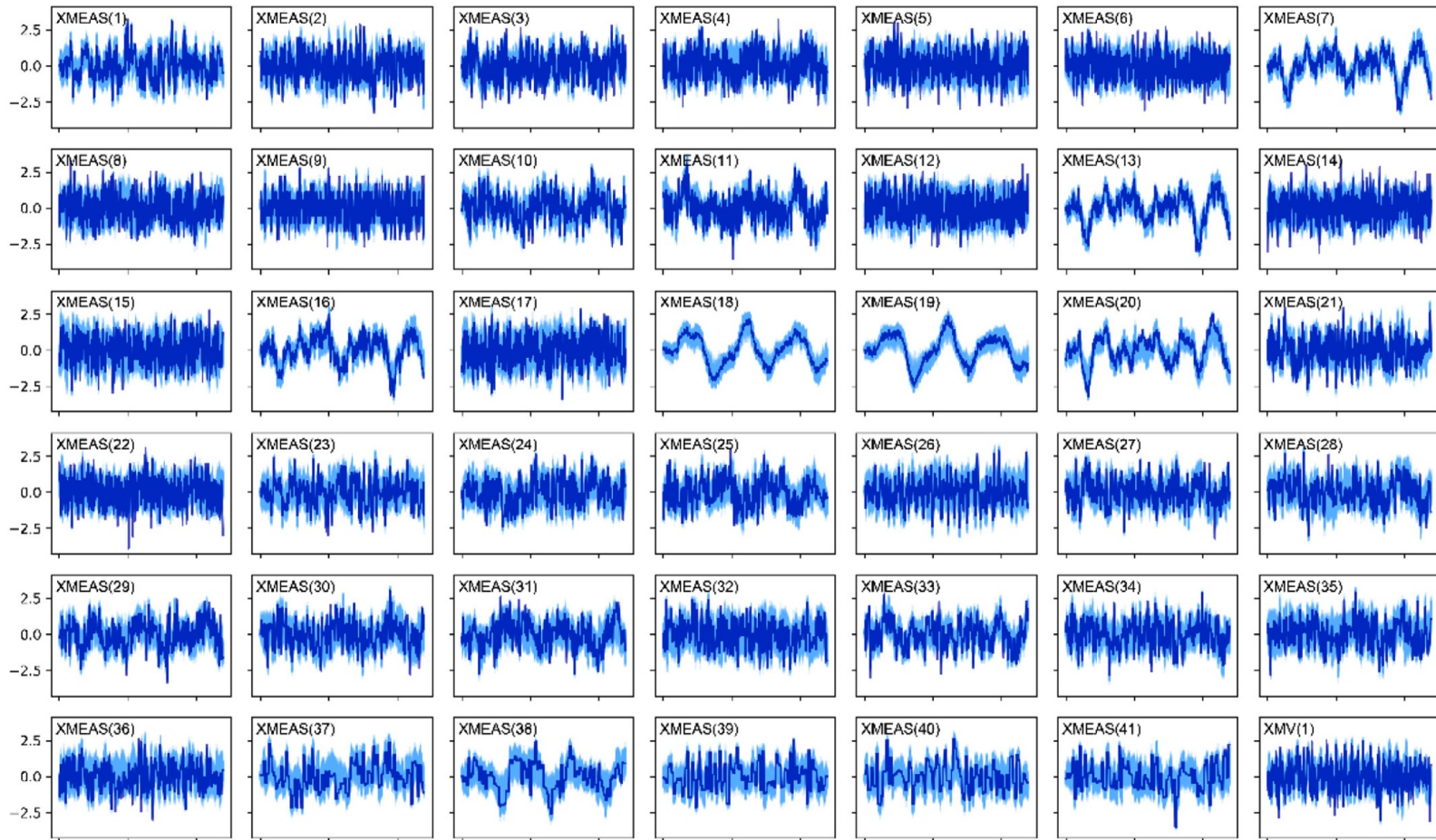

List of Potential Faults



- The following “faults” are created synthetically by the simulator
- These faults will cause the measured state variables to change from their normal operating conditions which further cause safety hazards.

Variable number	Process variable	Type
IDV (1)	A/C feed ratio, B composition constant (stream 4)	Step
IDV (2)	B composition, A/C ratio constant (stream 4)	Step
IDV (3)	D feed temperature (stream 2)	Step
IDV (4)	Reactor cooling water inlet temperature	Step
IDV (5)	Condenser cooling water inlet temperature	Step
IDV (6)	A feed loss (stream 1)	Step
IDV (7)	C header pressure loss—reduced availability (stream 4)	Step
IDV (8)	A, B, C feed composition (stream 4)	Random variation
IDV (9)	D feed temperature (stream 2)	Random variation
IDV (10)	C feed temperature (stream 4)	Random variation
IDV (11)	Reactor cooling water inlet temperature	Random variation
IDV (12)	Condenser cooling water inlet temperature	Random variation
IDV (13)	Reaction kinetics	Slow drift
IDV (14)	Reactor cooling water valve	Sticking
IDV (15)	Condensor cooling water valve	Sticking
IDV (16)	Unknown	Unknown
IDV (17)	Unknown	Unknown
IDV (18)	Unknown	Unknown
IDV (19)	Unknown	Unknown
IDV (20)	Unknown	Unknown

Step change in reactor cooling water temperature



- This fault could cause runaway reaction. The controller will increase the cooling water flowrate to bring the temperature down

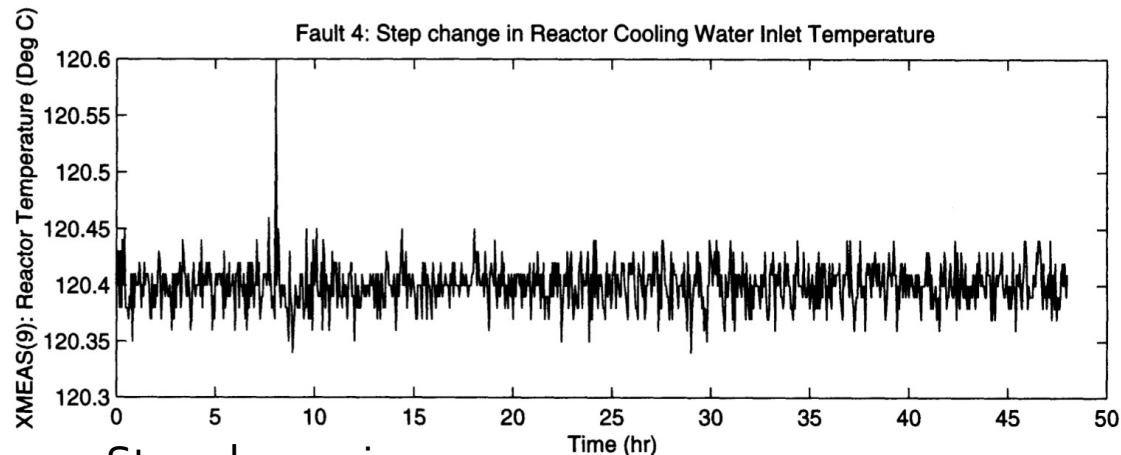
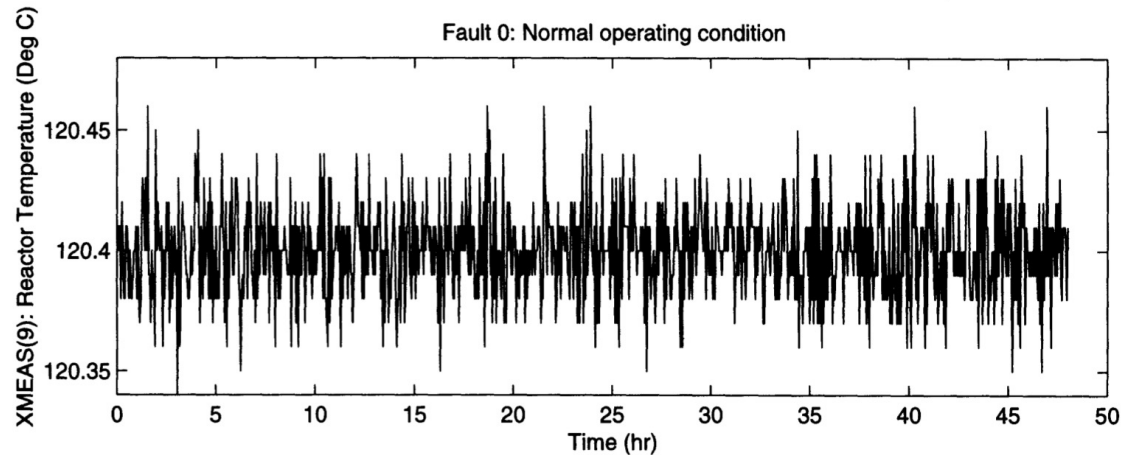

Step change in
reactor temperature

Classical Machine Learning Algorithm



- **Principal component analysis:** identify the principal components where the data have the largest variance. The non-principal components are “noise”.
- Approach: singular value decomposition

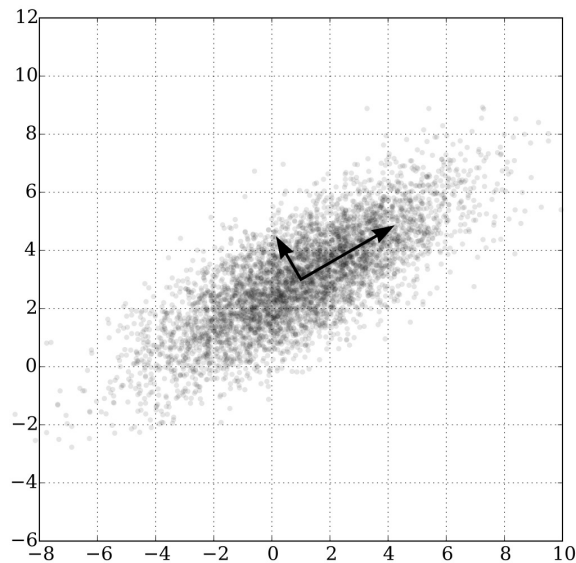

$$\begin{array}{cccc}
 \begin{array}{|c|c|c|} \hline \square & \square & \square \\ \hline \square & \square & \square \\ \hline \square & \square & \square \\ \hline \end{array} &
 \begin{array}{|c|c|c|} \hline \square & \square & \square \\ \hline \square & \square & \square \\ \hline \square & \square & \square \\ \hline \end{array} &
 \begin{array}{|c|c|c|} \hline \square & \square & \square \\ \hline \square & \square & \square \\ \hline \square & \square & \square \\ \hline \end{array} &
 \begin{array}{|c|c|} \hline \square & \square \\ \hline \square & \square \\ \hline \square & \square \\ \hline \end{array} \\
 \mathbf{X} & = & \mathbf{U} & \mathbf{\Sigma} & \mathbf{V}^* \\
 n \times m & & n \times n & n \times m & m \times m \\
 \\
 \begin{array}{|c|c|c|} \hline \square & \square & \square \\ \hline \square & \square & \square \\ \hline \square & \square & \square \\ \hline \end{array} &
 \begin{array}{|c|c|c|} \hline \square & \square & \square \\ \hline \square & \square & \square \\ \hline \square & \square & \square \\ \hline \end{array} &
 \begin{array}{|c|c|c|c|} \hline 1 & 0 & 0 & 0 \\ \hline 0 & 1 & 0 & 0 \\ \hline 0 & 0 & 1 & 0 \\ \hline 0 & 0 & 0 & 1 \\ \hline \end{array} \\
 \mathbf{U} & \mathbf{U}^* & = & \mathbf{I}_n \\
 \\
 \begin{array}{|c|c|c|} \hline \square & \square & \square \\ \hline \square & \square & \square \\ \hline \square & \square & \square \\ \hline \end{array} &
 \begin{array}{|c|c|c|} \hline \square & \square & \square \\ \hline \square & \square & \square \\ \hline \square & \square & \square \\ \hline \end{array} &
 \begin{array}{|c|c|c|} \hline 1 & 0 & 0 \\ \hline 0 & 1 & 0 \\ \hline 0 & 0 & 1 \\ \hline \end{array} \\
 \mathbf{V} & \mathbf{V}^* & = & \mathbf{I}_m
 \end{array}$$

- The region within the thresholds represents the Normal Operating Condition (NOC) under random noise.
- The region outside of the thresholds represents the systematic variation from NOC.
- Test statistics measure the variation in the reduced space and indicate any fault if the thresholds are violated.

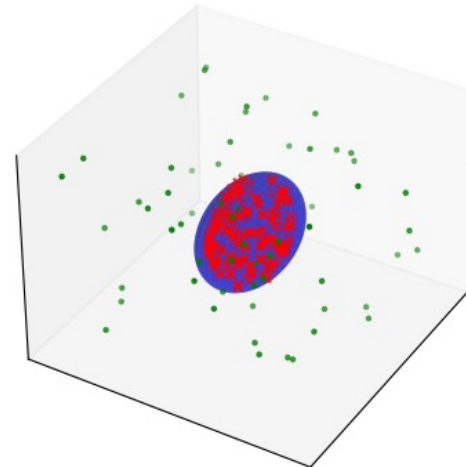
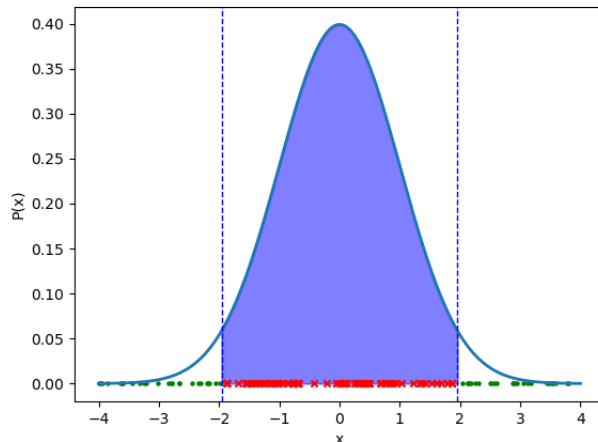

Anomaly Detection Using PCA



- T^2 statistics: describes how far the data is from normal operating condition

$$T^2 = \mathbf{x}'\mathbf{S}^{-1}\mathbf{x}$$

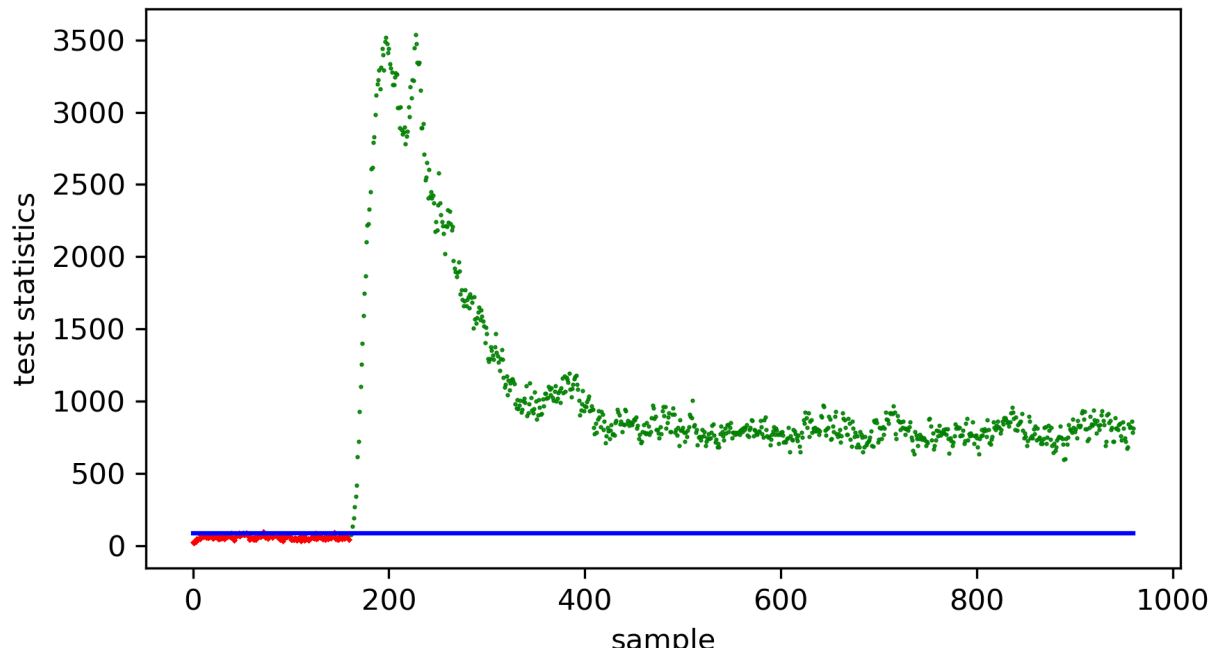

Limitation: Lack of interpretation.

LLM for Process Monitoring and Fault Detection



TEP-LLM demo x +

localhost:5173 120% ☆

TEP-LLM State: normal Rate: 1.0

- Chat
- Plot
- Fault Reports

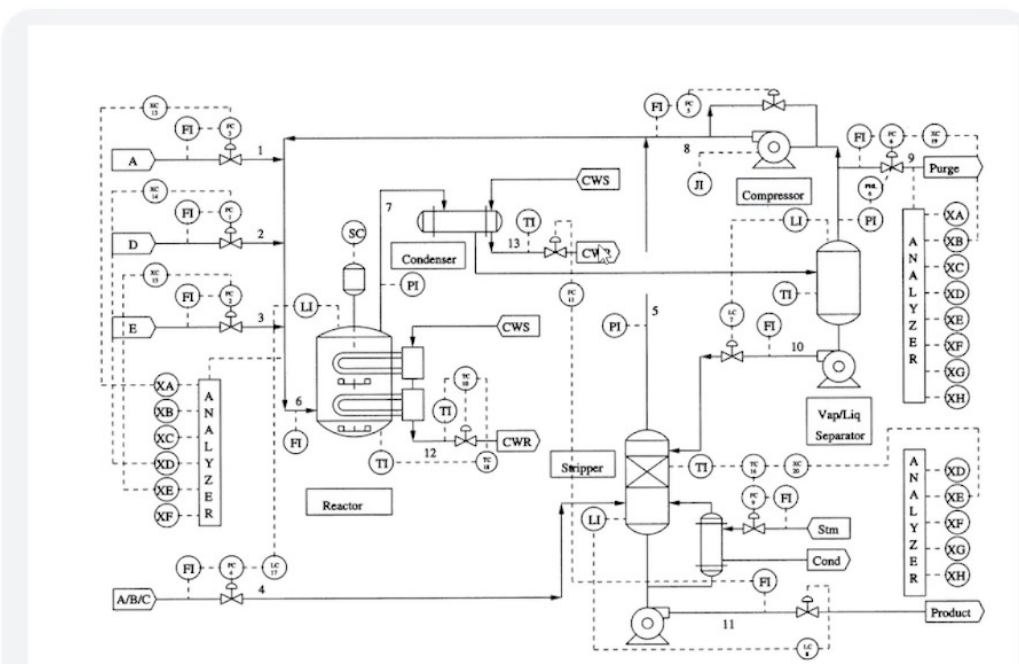

Fig. 8.1. A process flowsheet for the TEP with the second control structure in [205]

The process produces two products from four reactants. Also present are an inert and

Type your message here Send

Conclusions and Future Work



- Combining LLMs like GPT with mathematical models can get both explainability and rigor.
- With sufficient training data, we can fine-tune a LLM for tasks such as PHA, HAZOP, explaining controller behavior.