



2013 Annual Report

Monika Ivantysynova

Maha Professor of Fluid Power Systems

Lafayette, January 2014

Preface

In April 2013, Purdue University had the honor of hosting the annual site visit for the National Science Foundation (NSF)-sponsored Engineering Research Center (ERC) for Compact and Efficient Fluid Power (CCEFP). One of the major highlights of this exciting event was a comprehensive lab tour of the Maha Fluid Power Center. During the lab tour, all of our researchers presented their work to the NSF site visit team, the International Scientific Advisory Board (ISAB), the Industrial Advisory Board (IAB), university administrators, all CCEFP-sponsored faculty, and more than 50 graduate students representing the other six member universities of the CCEFP. We were very proud to successfully demonstrate the world's first hydraulic hybrid displacement controlled excavator during to our captive audience. This new machine allows for a 50% downsizing of the engine without any loss in productivity and offers a fuel savings of over 50% compared to current state-of-the-art excavators. Certainly the site visit was a key milestone in Maha lab history, but there were many other impressive highlights last year.

Another highlight of our research efforts in 2013 was the successful demonstration of the first displacement controlled steer-by-wire system implemented in a wheel loader. This novel and energy-efficient steering system has generated significant interest from both current and new industrial partners as well as the public. Details of this research have been published in three journal papers, presented at three international conferences, and shared with the public through five magazine articles in the last year alone.

Also in 2013, we successfully continued our research efforts toward discovering ways to improve the efficiency of pumps and motors, which form the heart of every fluid power system. I am proud to report that we were able to create the first comprehensive fluid structure interaction model for all three tribological pump/motor interfaces. Through continuous, intensive, experimental work and the use of a new test rig, we were able to confirm that squeeze effects due to transient surface pressure deformation need to be considered in the lubricating interface model in order to reproduce surface and fluid film temperature distribution measurements. This represents a very important discovery in understanding the main physical effects in pump and motor tribological interfaces.

The three major breakthroughs and discoveries I just shared were presented at key international conferences for our field. We traveled to Linköping, Sweden, where Marco Zecchi, Mike Sprengel, Naseem Daher, and Rohit Hippalgaonkar each presented a paper about their recent research results. I was invited to present a

keynote lecture on the *“Secret of the Fluid Film”* at the 8th International Conference on Fluid Power Transmission and Control (ICFP 2013) in Hangzhou, China last April. I also gave a keynote lecture on *“Displacement Control Actuation - Future and Challenges of Fluid Power”* at the workshop on fluid power systems at Beihang University in Beijing, China. Additionally, the Maha team was instrumental in leading and organizing this year’s ASME/Bath conference on Fluid Power and Motion Control, which took place in October 2013 in Sarasota, Florida. We presented two papers in Sarasota. Soon thereafter, I am proud to announce that at the SAE 2013 Commercial Vehicle Engineering Congress in Rosemont, IL, Naseem Daher won the 2013 SAE Excellence in Oral Presentation Award for his paper presentation on *“Pump Controlled Steer-by-Wire System.”* Finally, two of our researchers, Enrique Busquets and Mike Sprengel, traveled to Prague, Czech Republic, where they presented their research at the 22nd International Conference on Hydraulics and Pneumatics.

Much of our record year of research success is rooted in the more than 2 million US\$ of new research funding. In addition to the research funding, the Maha team also received major donations from industrial partners, which helped us to create important new test rigs and prototype machines. My special thanks go to Sauer-Danfoss, Sun Hydraulics, Parker Hannifin, Moog, Bobcat, Hydac and Bosch Rexroth for donating major equipment and components to the Maha lab. Finally, my special thanks additionally go to Ken and Susan Warren who increased their personal gift to Maha to \$ 12,000 this past year.

A key contributor to our modeling breakthroughs, Marco Zecchi, successfully defended his PhD thesis in December 2013. Marco returned to Italy after 3.5 years at Maha, where he is now starting his career with Danfoss.

The Maha team reached its maximum size in terms of graduate students and visiting researchers in 2013. Lizhi Shang joined Maha as new PhD student in January 2013. And, in August 2013, we welcomed six new graduate students: Meike Ernst, Tyler Bleazard, Phil St. Hilaire, Amine Nhila, Kyle Williams, and Chenhao Ma. Maha also welcomed Bjoern Bahl, a new IEASTE exchange student from Germany. And, during summer 2013, we hosted three SURF students: Jordyn Miller, Jose Edgar Gomez, and Yangqiao Zheng. We are thrilled to report that Jordyn nominated Andrew Schenk for the 2013 SURF “Graduate Student Mentor of the Summer” award, which he received for his excellence in technical and instructional competence, supervision/guidance, passion/enthusiasm for research, and motivation.

I would like to thank all team members for their outstanding contributions in 2013. It is a great pleasure to present the following survey of our activities and achievements during this past year. I am confident that we will continue our exciting and successful research. I wish all the members of our team much success during 2014.



Dr. Monika Ivantysynova
Maha Professor Fluid Power Systems
Director Maha Fluid Power Research Center



Contents

1	RESEARCH ACTIVITIES	6
2	RESEARCH FACILITIES	31
3	RESEARCH GRANTS	45
4	PUBLICATIONS, INVITED LECTURES, PATENTS AND REPORTS	46
5	THESES COMPLETED IN 2013	50
6	INTERNATIONAL CO-OPERATION	51
7	INTERNATIONAL AND NATIONAL CONFERENCES ATTENDED	52
8	MAHA HOSTED & ORGANIZED EVENTS	56
9	MAHA IN THE NEWS	68
10	AWARDS, HONORS, AND RECOGNITIONS	78
11	EDUCATIONAL ACTIVITIES	80
12	MAHA SOCIAL EVENTS	85
13	INTERNATIONAL JOURNAL OF FLUID POWER	94
14	MAHA TEAM IN 2013	96
15	DONORS, SPONSORS, PARTNERS, & GUESTS	103

1 Research Activities

After two consecutive, highly successful years, we are proud to declare the year 2013 again as one of the most successful years to-date. We achieved the highest number of publications and patents awarded and received research funding on the same high level of the last two years. Also, the Maha team continued to grow last year, achieving the highest number of graduate students and visiting scholars in lab history. Research activities at the Maha lab are broadly divided into two areas:

- 1) **Research into efficient hydraulic actuation and drive systems**, which includes displacement controlled (DC) systems, novel hydraulic power trains (hybrid and non-hybrid), power management and control, active vibration damping and machine diagnostics.
- 2) **Research into design and optimization of piston pumps and motors**, which includes modeling, control, experimental investigations and testing. Current main focus is on modeling of fluid structure interaction phenomena, thermal behavior and noise generation and propagation in order to gain a better understanding of physical phenomena influencing pump performance. Long term goal is to provide methods and tools for computational design and digital prototyping of pumps and motors.

In general the research activities involve extensive computational, experimental, and theoretical work. During the last sixteen years, a comprehensive fluid power research laboratory has been built and equipped with pump and motor test rigs, actuator test rigs, drive-line control, and transmission test rigs including test machines as well as several specialized test rigs for the investigation of tribological systems of displacement machines.

1. Research Highlights in 2013

- The Maha team creates the first comprehensive fluid structure interaction model for all three tribological pump/motor interfaces. The model is fully implemented and executed and ready for application for general pump and motor analysis and design optimization.
- Marco Zecchi's experimental work on the cylinder block/valve plate interface confirm that squeeze effects due to transient surface pressure deformation need to be considered in order to reproduce surface and fluid film temperature distribution measurements. This represents a very important discovery in understanding the main physical effects in pump and motor tribological interfaces.

- Maha presents the world's first displacement controlled (DC) steer-by-wire system for a wheel loader. The system allows for more advanced steering functions and helps to save fuel. Measurement showed a 40% productivity improvement for vehicle steering. Naseem Daher submitted three journal papers and two conference papers about this novel steering concept, which can be applied to many other vehicles.
- The first hydraulic hybrid excavator with DC actuation systems for boom, bucket, and arm has been built and successfully tested at Maha. NSF nominated the machine for the 2013 Popular Mechanics Breakthrough Award!
- The application of Maha's newest fluid structure interaction model for investigation of surface shaping for the piston/cylinder interface shows very promising results with an average power loss reduction of 60% for pumping mode.
- Mike Sprengel proposed and investigated a new concept for hydraulic hybrid transmissions, which uses a combination of hybrid and hydrostatic operation in a new circuit solution. Control concepts for this new blended hybrid technology have been presented in Sprengel, M. and Ivantysynova, M. 2013. Control Strategies for a Novel Blended Hydraulic Hybrid Transmission. Proceedings of the 22nd International Conference on Hydraulics and Pneumatics. Oct. 24-25, 2013. Prague, Czech Republic, pp. 15-22.
- The Maha team finished its work on a 22-ton displacement controlled excavator prototype machine and measured 35% fuel savings compared to the standard valve controlled machine.
- Enrique Busquets successfully implemented and tested the novel pump switching technology for DC actuation in Maha's modified JIRA test rig.
- Paul Kalbfleisch successfully developed and tested a new version of VpOptim, a program allowing for the first time an effective computational method for valve plate design and optimization. The program was used to successfully redesign and optimize a valve plate in order to reduce control effort and noise for one of our industrial partners.

Our research activities are focused in five main areas:

- 1) Advanced energy saving hydraulic actuators, new system architecture, and controls
- 2) Advanced hydraulic hybrid power trains and control
- 3) Fluid Structure Interaction in critical piston pump/motor interfaces
- 4) New computational design methods for piston pumps and motors
- 5) Investigation of pump and transmission noise sources

Research related to the first three listed areas is supported by the NSF through participation in the CCEFP and by several industrial partners. The other topics are funded by industry sponsors.

2. Research into Efficient Hydraulic Actuation and Drive Systems

Advanced Energy-Saving Circuits for Hydraulic Actuation

This research area involves the development of novel throttle-less hydraulic actuation architectures together with necessary motion control concepts, to improve system efficiency while maintaining or improving productivity. A closed-circuit throttle-less solution, called displacement controlled (DC) actuation, was first developed and successfully tested in Professor Ivantysynova's lab in 1998 at Duisburg University in Germany. Since then much research effort has been directed toward introduction of this concept into mobile machines such as wheel loaders, excavators and skid-steer loaders and for the purpose of throttle-less actuation of working hydraulics and auxiliary functions, as well as active vibration damping.

In August 2010, a prototype 5-ton DC excavator built at Maha, using pump-controlled actuation (PCA) for all functions showed 40% fuel savings in side-by-side measurements against a standard 5-ton excavator using load-sensing architecture. These measurements were made after detailed modeling of the PCA and LS architectures in 2008 and 2009, using a co-simulation model that captured the dynamics as well as the mechanics of both systems and predicted these savings.

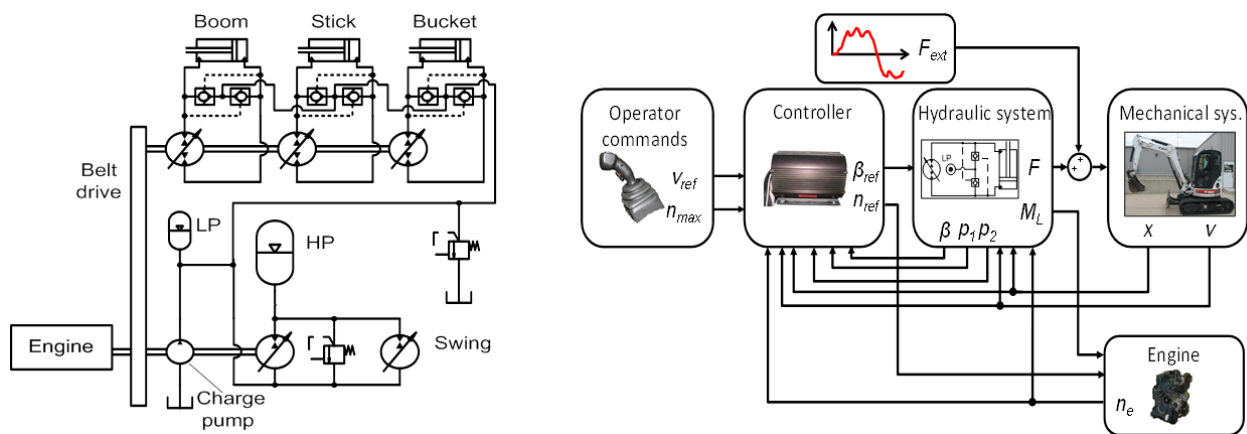

Fig. 1: Series-Parallel (S-P) Hybrid Pump-Controlled Excavator Architecture and Co-Simulation Model

A novel hydraulic hybrid excavator architecture (Fig. 1) was proposed by Zimmerman and Ivantysynova (SICFP, 2011), which retained PCA for the boom, stick and bucket functions while employing a series-hybrid hydraulic swing drive. The architecture enabled 50% engine downsizing (which was first predicted in simulation by Zimmerman), while meeting aggressive digging cycles (representing peak power demands from the excavators). Using a conservative power management scheme ('single-point strategy'), the architecture also enabled fuel savings in excess of 52% over the standard, valve-controlled 5-t excavator (and 20% fuel savings over the non-hybrid PCA architecture).

In 2013, this architecture was implemented on a mini-excavator, together with implementation of energy management algorithms that limited engine power to 50% while meeting digging cycles. Figure 2 shows the results of implementation of the 'single-point' strategy, wherein the engine speed was operated at its maximum governed speed and maintained at a constant torque (near the maximum torque of an engine with 50% reduced power) through appropriate control of the primary unit.

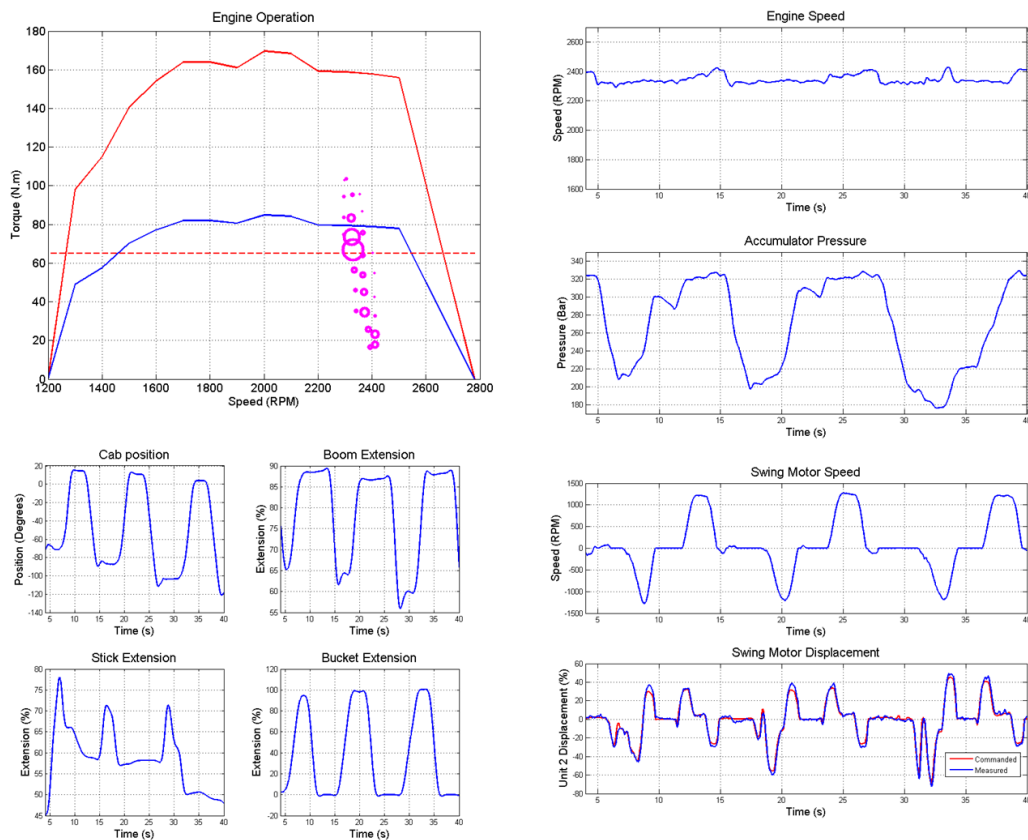

Fig. 2: Measurement Results with the Single-Point Power Management Strategy (Digging Cycle)

Another strategy, called the minimum-speed strategy (Hippalgaonkar, Ivantysynova & Zimmerman (IFK, 2012)), that exploited all degrees of freedom of the hydraulic hybrid architecture was also implemented on the excavator. In simulation, this strategy showed higher efficiency than the single-point strategy and allowed replication of optimal control results obtained from dynamic programming (Zimmerman, Ivantysynova and Hippalgaonkar (ASME-Bath, 2012)), for the series-parallel hybrid hydraulic architecture with a 50% downsized engine. In implementation of this strategy, the engine power (the engine was not actually downsized on the mini-excavator at Maha) was limited to be below 25 kW (slightly above 20.5 kW, which is 50% of the maximum engine power), while exploiting engine speed variation (Fig. 3).

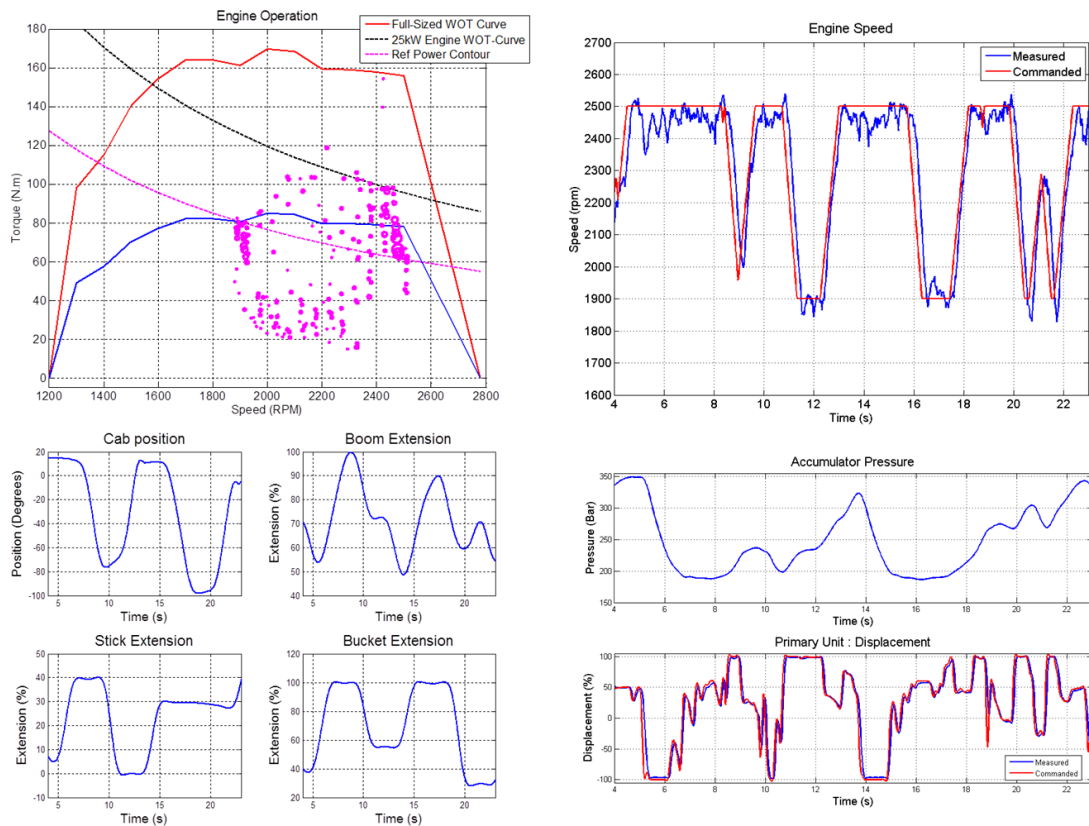

Fig. 3: Measurement Results with the Single-Point Power Management Strategy (Digging Cycle)

This strategy also showed higher efficiency over the single-point strategy for the parallel-hybrid hydraulic excavator architecture (Hippalgaonkar, Zimmerman & Ivantysynova, SAE Comvec-2011)), with a 50% downsized engine. Details of the closed-loop speed control strategy employed for the swing drive are outlined in Hippalgaonkar & Ivantysynova (SICFP, 2013).

In addition to the investigation of the hybrid swing drive, the investigation of DC actuation with pump switching was conducted at Maha. This concept was born from one of the major obstacles for DC multi-actuator machines: the increased production costs due to the one-pump-per-actuator requirement. Up to 2011, research in DC technology at Maha mainly focused on architectures with one pump per actuator. This certainly increases machine production costs especially for large machines where for optimal operation the required pump sizes or number are very large. In an attempt to reduce machine production costs and meet machine space constraints, the excavator prototype built on 2006 made use of on/off valves to direct flow from one pump to two actuators based on two machine operating modes: 1) driving mode and 2) digging mode. In this setting, since each pump was dedicated to a specific actuator, not only machine operation is limited but also operator performance is greatly reduced. To overcome the aforementioned impediments, a new technology also based on the use on/off valves to direct flow from a pump to different actuators was developed. Fig. 4 shows a hydraulic circuit of pump switching for two DC actuators.

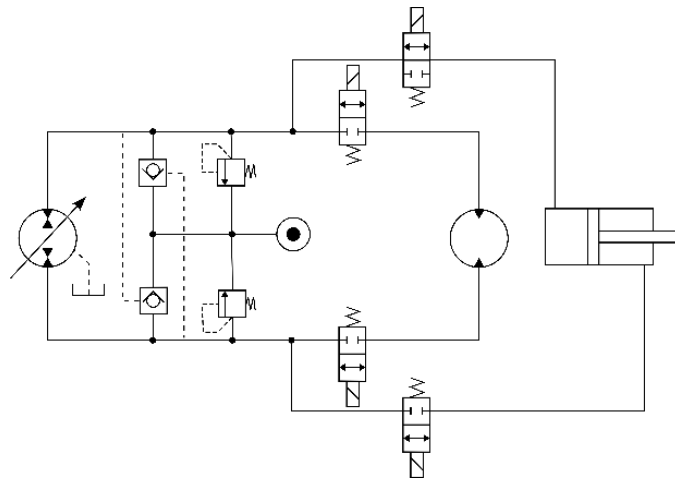

Fig.4: Displacement Controlled Actuators with Pump Switching

Pump switching may also be utilized to reduce the size of the pumps in a machine. Through the combination of two or more pump flows, actuators' high flow requirements can be fulfilled. Figure 5 shows a basic hydraulic circuit of the idea.

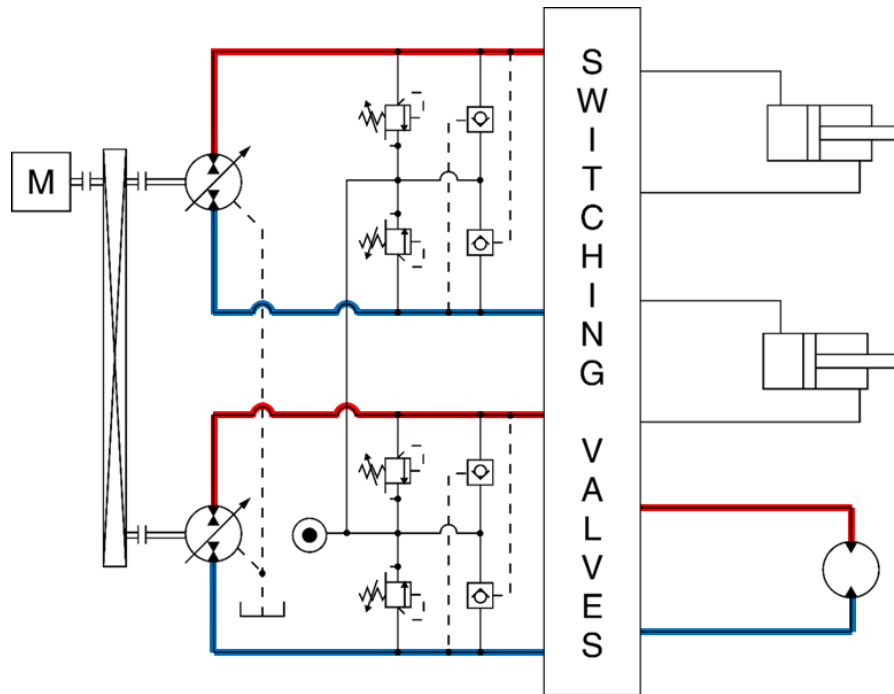

Fig. 5: Pump Switching Architecture for High Flow Requirements

On the hydraulic architecture side, the main objective behind this new idea was to maximize the number of combinations of operating actuators while minimizing the number and the size of the installed pumps. With this in mind, a hydraulic manifold was designed for the operation of two actuators as shown in Fig. 4 to centralize and distribute the flow from the installed pumps. On the controllability aspect of this new technology, the concept required intelligent controls which would not only smoothly switch pump flow to different actuators but also guaranteed machine performance and stability.

To study the concept, the JIRA test rig was utilized as the demonstrator. A high-fidelity nonlinear model representative of the test rig was created to simulate the switching scenarios. Through the use of this model, it was determined that the current DC pump bandwidth requirements ($\pm 5\%$ displacement at 20Hz) were sufficient to accomplish pump switching. In addition, a linear model of the plant was created and validated through measurements for the plant dynamics and hydraulics on the MATLAB Simulink environment. This last model allowed for the creation of the Feedforward + Full State Feedback linear control law shown in Fig. 6.

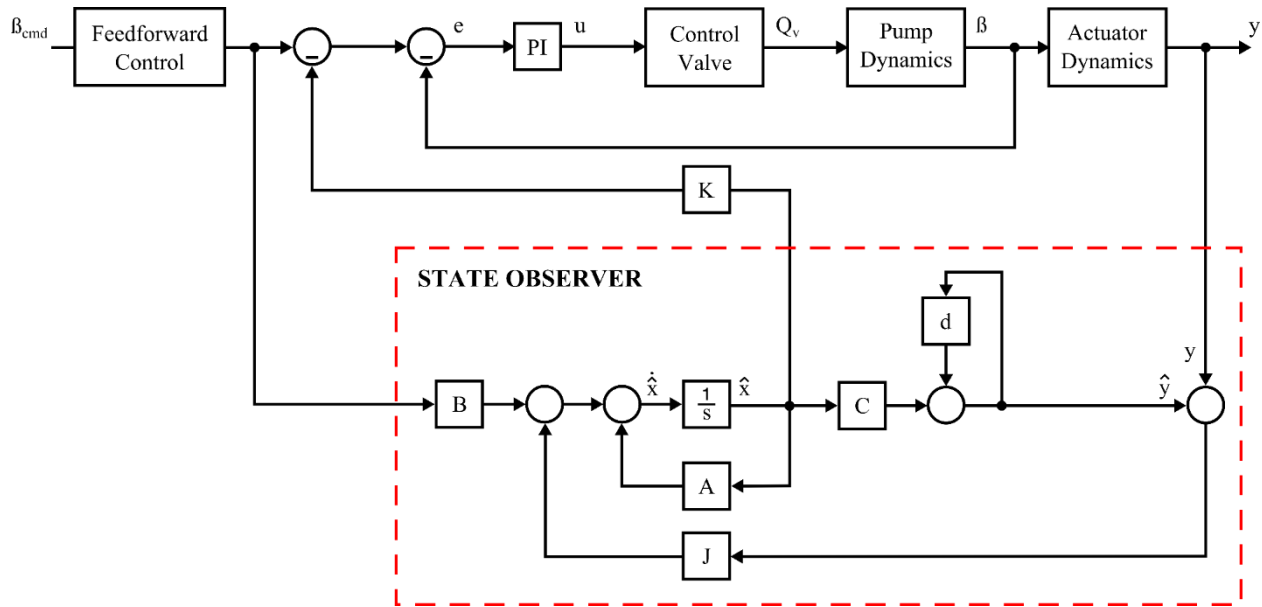

Fig. 6: Feedforward + Full State Feedback Linear Control Law

Pump switching was successfully implemented and demonstrated during the CCEFP annual meeting on the JIRA test rig. The hydraulic architecture allowed for the reduction of production costs and improved overall system efficiency by reducing parasitic losses, while the control algorithms allowed for the smooth and stable sequential operation of the two actuators and improved performance and operability. Figures 7 and 8 show the actuator and pump high pressures and pump displacement command and actual, respectively. It can be observed that the formulated controller acts to maximize performance while minimizing pressure pikes therefore optimizing machine operability.

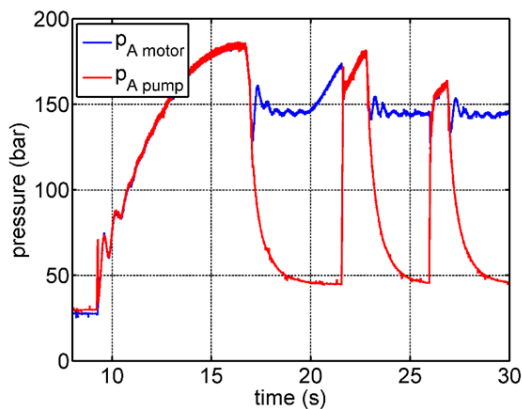

Fig. 7: Actuator and Pump High Pressure Side

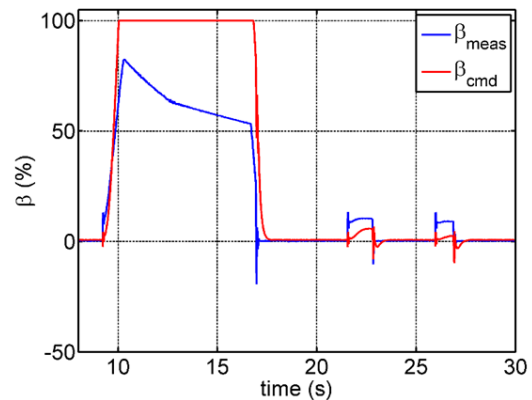

Fig. 8: Pump Measured and Commanded Displacement

Novel Energy-Saving Electrohydraulic Steer-by-Wire System via Pump Displacement Control Actuation

Pump displacement control (DC) is an energy-efficient alternative to traditional valve control. A novel steer-by-wire (SBW) technology based on DC actuation is under current research and development. A hydraulic schematic of the proposed system is shown in Fig. 9 below. The actuator (8) velocity is controlled by adjusting the pump (2) speed, displacement, or both. The differential fluid flow between the single-rod actuator's uneven sides is overcome by means of pilot-operated check valves (6). The low pressure system has its own fixed displacement charge pump (4) that provides continuous flow to the cylinder's low pressure side. The low pressure level setting is controlled via a pressure relief valve (5). The system is protected against over-pressurization by means of high pressure relief valves (7). The pump control system (3) consists of a proportional control valve that meters flow to a double rod actuator that is mechanically coupled to the pump swash plate.

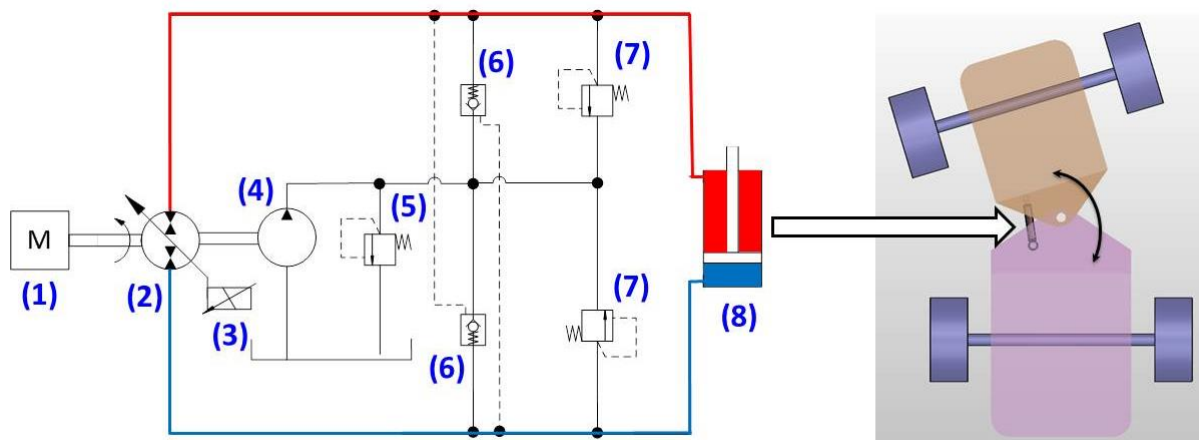

Fig. 9: DC Electro-hydraulic Steering System – Hydraulic Schematic

Two main components are required by the DC steering system: a dedicated variable displacement pump and a tactile feedback device to control the steering wheel torque level. The two subsystems are controlled by an on-board electronic control unit (ECU) and vary based on vehicle speed, articulation angle, and steering wheel velocity as depicted in Fig. 10.

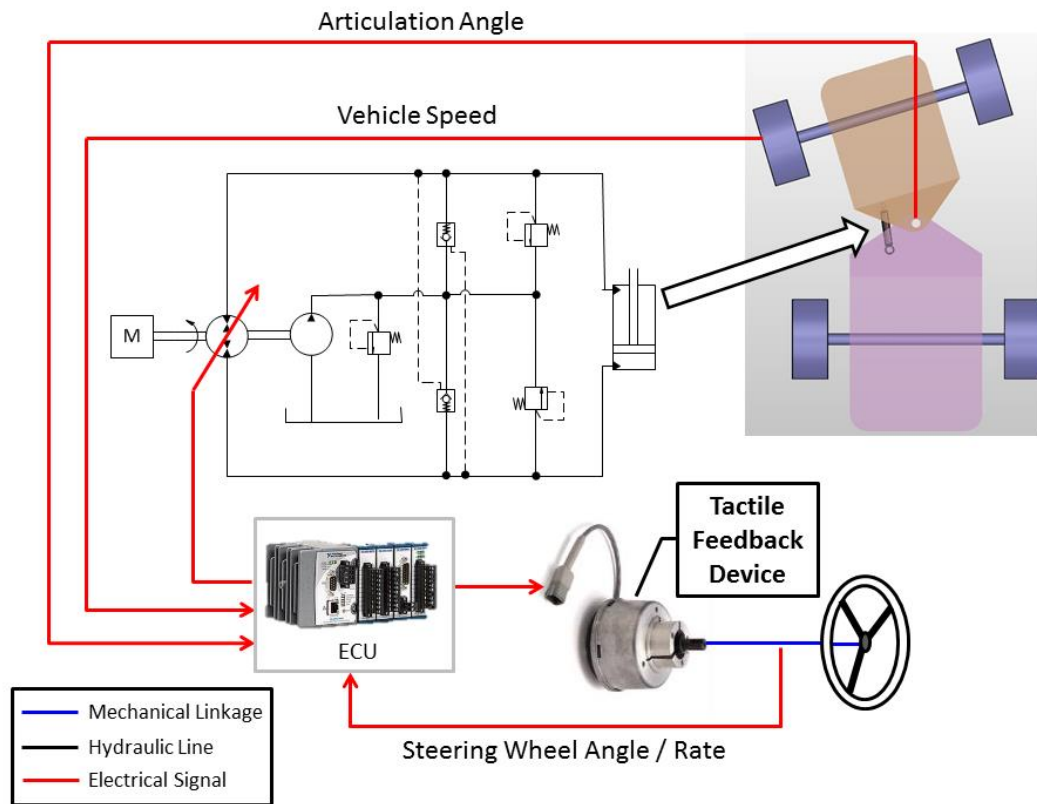

Fig. 10: DC Steering System Depiction

A high-fidelity nonlinear dynamic model is generated for the entire vehicle system, which includes a hydraulics module and a mechanics model as shown in Fig. 11. The hydraulics subsystem is modeled in MATLAB Simulink® environment, while the mechanics subsystem is modeled in MSC Adams software.

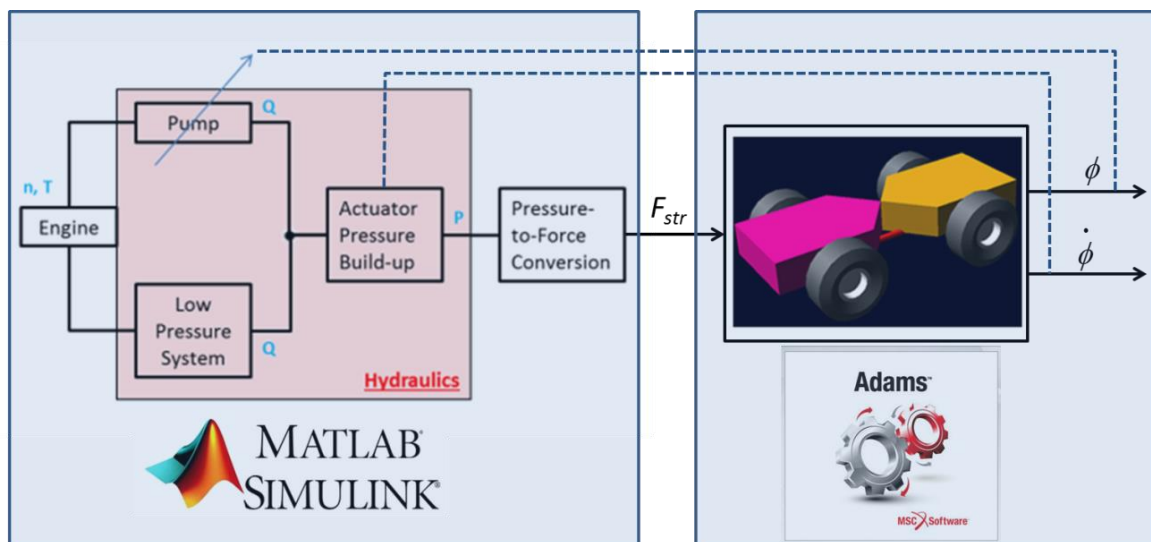

Fig. 11: Block Diagram of Steering System Dynamic Model

Linear models are derived for each of the hydraulics and the mechanics subsystems, and the two models are coupled at the steering actuator interface. The mechanics subsystem is based on a multi degrees-of-freedom vehicle dynamics model based on Lagrangian mechanics principles. The hydraulics subsystem includes the pressure build-up equations of the steering actuator chambers. The obtained model is a linear time-invariant (LTI) single-input single-output (SISO) system with pump displacement as its input and articulation angle as its output. A linear control law that includes feedforward and feedback is designed as shown in Fig. 12.

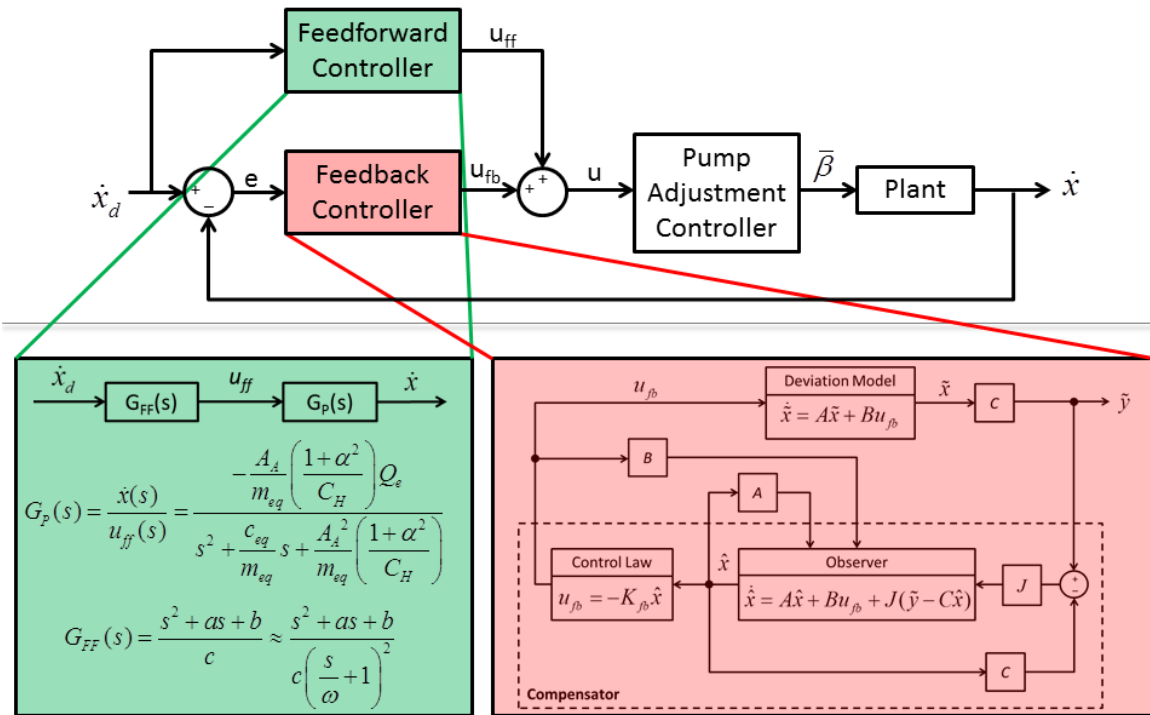

Fig. 12: DC Steering System Controller Structure

A designated prototype test vehicle, a compact 5-ton wheel loader, is overhauled to retrofit a DC steering system, which includes the following main hardware components as shown in Fig. 13: a variable displacement axial piston pump (dashed red) dedicated to the steering actuator, a proportional control valve (dashed green) to adjust the swash plate angle, a gear type charge pump (dashed blue) to supply flow to the low pressure source, and a tactile feedback device (dashed orange) to provide torque feedback at the steering wheel. For research and algorithm development purposes, a load-cell torque sensor (dashed yellow) is installed to measure driver effort, and a slip ring (dashed purple) is used for cable management (infinite no. of rotations).

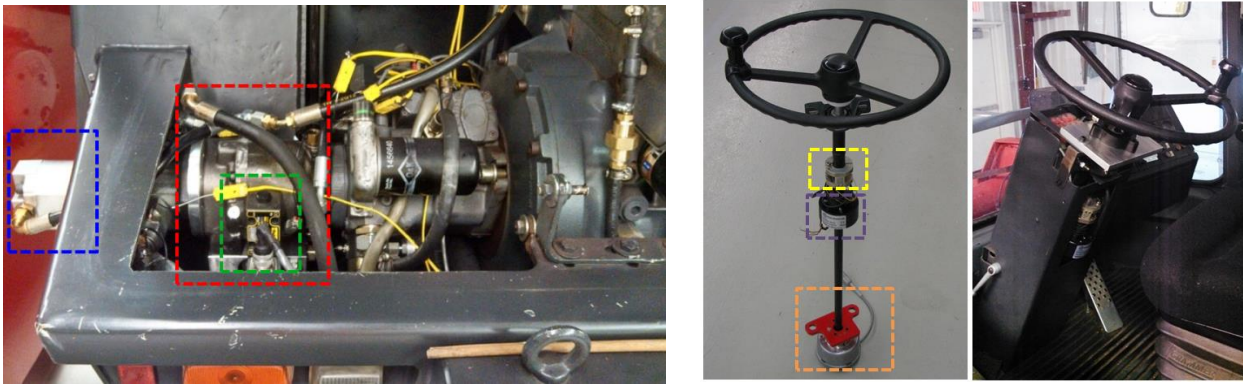

Fig. 13: New DC Steering System Hardware Components

The prototype wheel loader was baseline tested according to a steering-only cycle during which all other hydraulic functions are inactive, in order to characterize the steering system contribution to the energy losses incurred during the event. The stock machine had a valve controlled (hydrostatic) steering system, for which the valve alone is responsible for 61% (2.14MJ), which is more than the entire energy losses incurred with the DC steering system (1.52MJ).

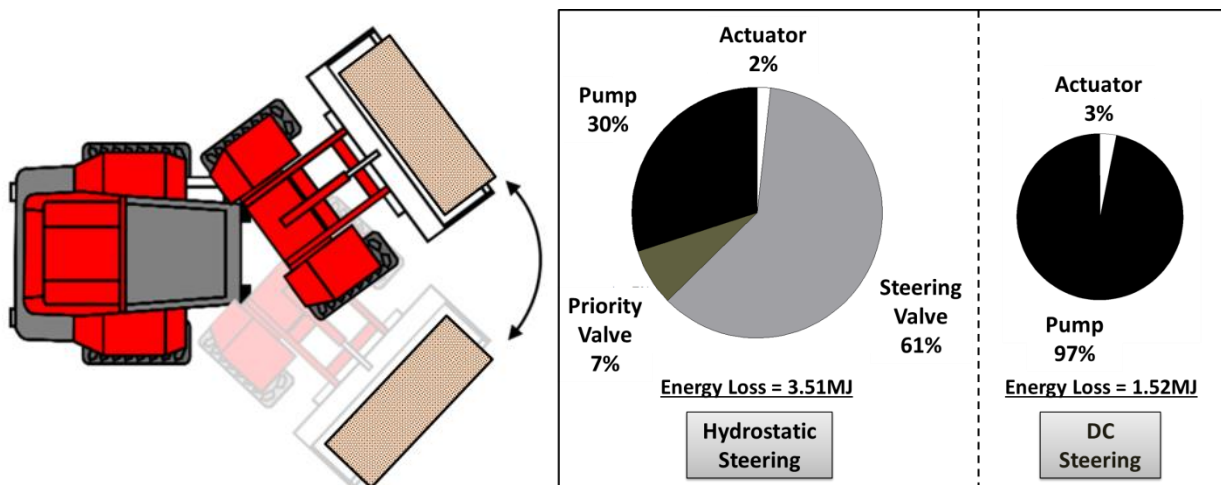

Fig. 14: Steering-only Cycle (left) and Energy Losses Comparison (right)

The reduced energy losses of the DC steering system translate into 14.5% fuel-savings, 22.6% increased productivity, for an overall fuel usage efficiency boost of 43.5% as shown in Table 1. Fuel consumption is measured by weighing the mass of an auxiliary fuel tank pre- and post-testing. Steering work is computed by integrating the product of steering torque and articulation velocity over the event time. Fuel efficiency is determined by taking the ratio of steering work done per fuel mass consumed.

Table 1: Systems Fuel Consumption, Productivity, and Efficiency Comparison

	Fuel Consumption [kg]	Total Steering Work Done by Machine [MJ]	Steering Work per Fuel Mass [MJ/kg]
Conventional Valve Controlled Steering	0.291	0.639	2.232
New DC Steering	0.249	0.784	3.203
Difference	-14.5%	22.6%	43.5%

Future research is focused on integrating active safety functions via active steering such stability control based on virtual yaw rate sensing; investigating adaptive control schemes to aid the machine in coping with parametric uncertainties and uncertain nonlinearities associated with hydraulically actuated systems; failsafe, redundancy, and fault-tolerance of the new SBW system; and tele-operation of the steering system to demonstrate the system’s capacity for full autonomous operation.

Advanced Energy-Saving Hybrid Power Trains

Research in this area focuses on investigating the feasibility and performance of alternative drive line technologies for different types of vehicles. The aim is to develop system concepts for minimizing fuel consumption and exhaust emissions without limiting the vehicle’s driving power. A special software tool called PSDD (Power Split Drive Design) has been developed to support virtual prototyping of power split drives, multi-motor hydrostatic transmissions and hydraulic hybrid power train configurations. The research activities are supported by performance measurements using pump and motor test rigs and a hardware-in-the-loop power train test rigs based on hydrostatic dynamometers. Current areas of research include:

- Investigating power split hydraulic transmission for heavy on-road and off-highway applications
- Virtual prototyping of power split drives and hydraulic hybrid power trains
- Optimal control of hybrid transmissions to aid in vehicle baselining and optimal sizing

Novel Blended Hybrid Architecture

During 2013 research continued on a novel transmission architecture for on-road and off-highway vehicles. This so call “Blended Hybrid” architecture was originally proposed by Sprengel and Ivantysynova in 2012

(Figure 15) and has several advantages over existing systems. First the blended hybrid often functions as a hydrostatic transmission which has the benefit of operating at the lowest pressure required for a given load. This property allows the blended hybrid to operate at pressures below the minimum accumulator pressure of a series hybrid, improving efficiency during low power driving. The hydrostatic path of the blended hybrid also increases transmission stiffness to near that of mechanical transmissions, improving driver response and preventing a “spongy” feel. Finally the blended hybrid removes the need for over center units connected to the wheels which may have benefits in certain situations. During 2013 two research papers were published investigating the blended hybrid. First Sprengel and Ivantysynova compared a baseline automatic transmission, a series hybrid transmission, and the blended hybrid transmissions in a class 2 truck and presented the findings at the SICFP conference in Linköping, Sweden. An overall control strategy for the blended hybrid was then presented by Sprengel and Ivantysynova at the ICHP conference in Prague, Czech Republic.

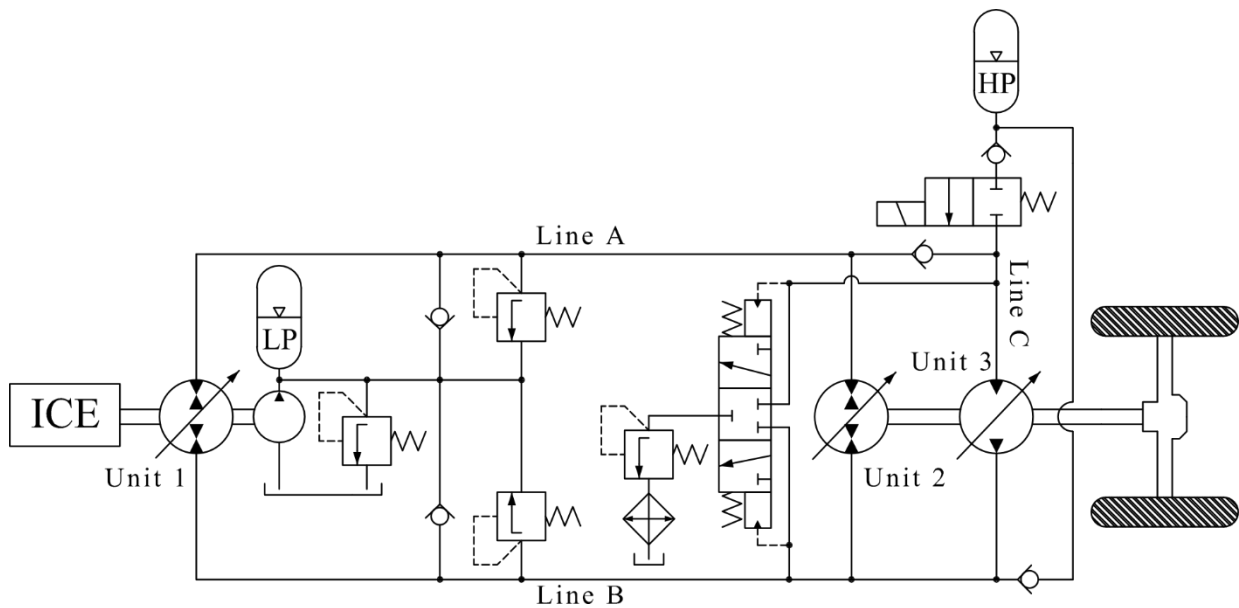

Fig. 15: Blended Hybrid Architecture

Optimal Control

It is well known that how a hybrid transmission is controlled has a major impact on the transmission’s resulting fuel economy. In fact a poor system architecture with a good control scheme can outperform a superior system architecture with a substandard controller. Consequently this can obscure which transmission architectures merit further research. One method around this problem is to optimally control a transmission, thereby removing control as a factor affecting fuel consumption. Previously Dynamic Programming (DP) has been successfully used in the Maha lab to optimally control several transmissions and

a hybrid excavator. However configuring the DP algorithm for a specific application required considerable effort and limited the applications in which it was used. In 2013 researchers at the Maha lab developed a new DP algorithm which is capable of optimally controlling existing simulation models with comparatively little effort. This new tool has already been used to optimally control a number of transmissions and will expand the types of studies which can be carried out in the future.

PSDD - Power Split Drive Design Simulation

One of the main reasons for the use of power split drives in many applications is the possibility of having a continuously variable transmission with simultaneously high efficiency in a wide range of operating parameters. This requires the consideration of real loss behavior of all parts of the transmission. Due to the strong dependence of losses of displacement machines on operating parameters the integration of precise loss models is necessary. The PSDD software tool (Fig. 16) allows for the calculation of system parameters including power losses in the whole range of operation for any kind of power split drive structure. This provides the design engineer with very good support during the design process and helps him to find an optimal structure of the power split drive. The tool has libraries for hydrostatic components, gears, clutches, planetary gear sets, engines and accumulator models. These libraries can be extended and completed by the user easily. An open database of the most common structures of power split drives is implemented in the CAE tool. The PSDD software tool is built in a modular way on the Matlab and Simulink platforms. To increase the fidelity of simulation models highly accurate empirically based loss models should be used.

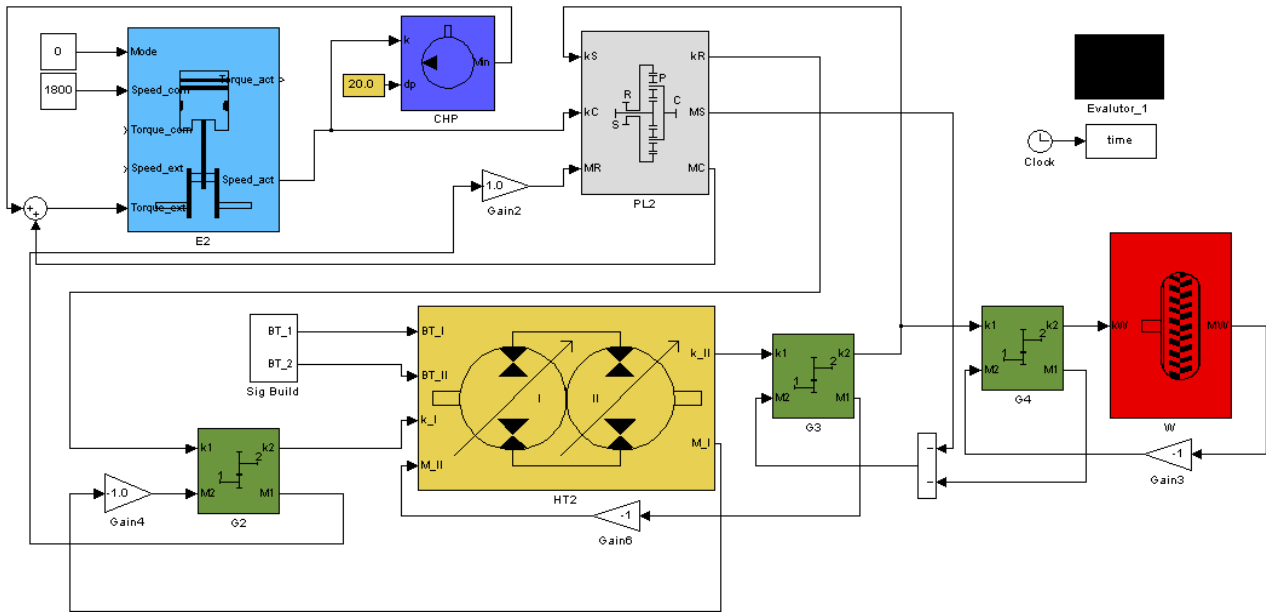

Fig. 16: PSDD Simulation Model

3. Research into Design and Optimization of Piston Pumps and Motors

Advances in Modeling, Fundamental Understanding, and Optimization of Axial Piston Pumps

The novel swashplate type axial piston pump models developed at the Maha Fluid Power Research Center are the product of more than 15 years of experience and research by numerous individuals. While part of the piston pump modeling focuses on reducing noise generation and improving the swashplate controllability, a large effort is made to develop models which simulate the full fluid film lubrication performance between the three primary sliding interfaces of a swash plate type axial piston pump or motor (Fig. 17):

- Piston/cylinder block bore interface
- Cylinder block/valve plate interface
- Slipper/swashplate interface

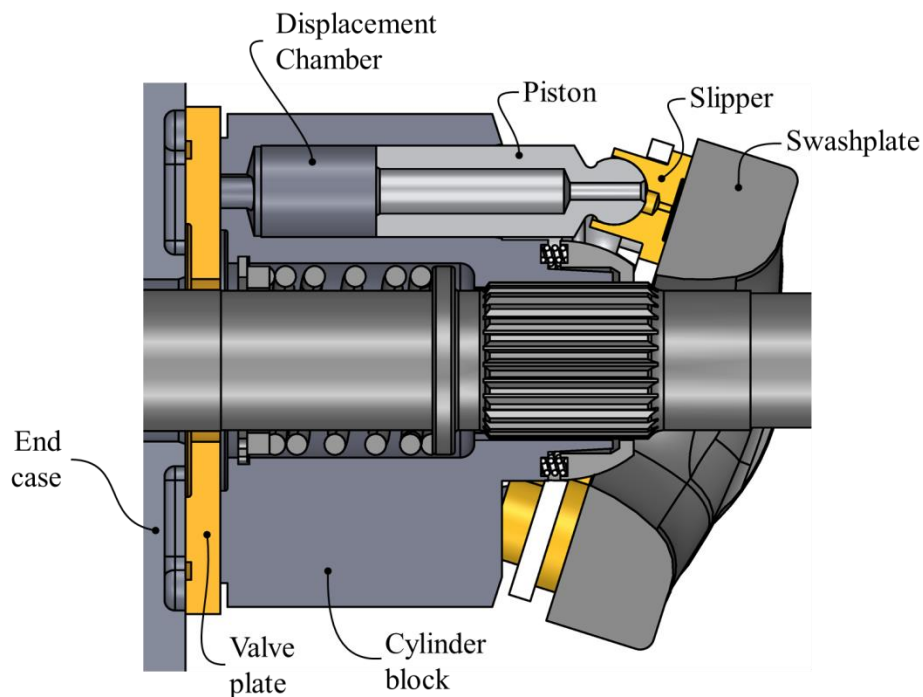

Fig. 17: Swash-plate type axial piston machine cross section

The primary function of these lubricating fluid films is to transmit large compressive loads across the sliding interfaces as well as limit the leakage of fluid from the displacement chamber into the pump or motor housing.

Each lubricating interface model allows capturing the complex fluid-structure interaction and thermal phenomena affecting the non-isothermal fluid film conditions. In particular, the model considers the change in fluid film thickness and squeeze film effect due to the component micro-motion as well as the solid boundaries elastic deformations. The elastic deformation of the surfaces is related to the fluid film pressure and thermal stresses.

The model couples iteratively different numerical domains and solution schemes, as depicted for the case of the piston/cylinder by 18. Different numerical methods, discretization schemes and solvers are necessary in order to solve all different physical problems/domains. The communication and coupling is allowed through advanced interpolation methods based on nearest neighbors searching. The three main numerical modules are briefly described as follows:

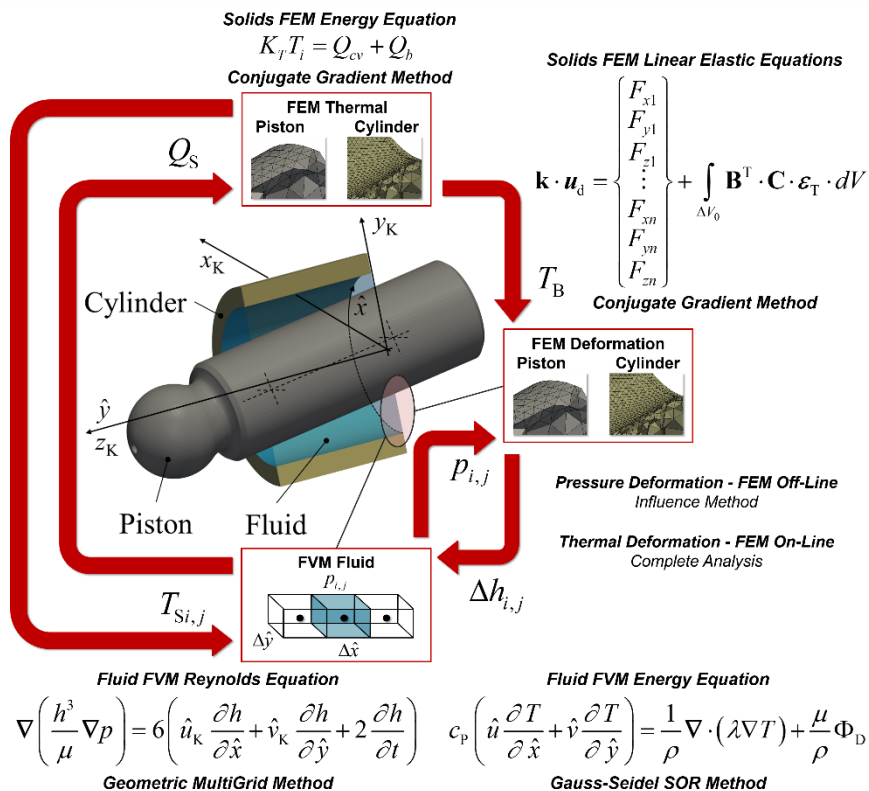

Fig. 18: Fluid Structure Interaction and Thermal Model

- 1) **Fluid Film Finite Volume Non-Isothermal Flow Model:** this module predicts the instantaneous pressure distribution and temperature distribution in the lubricating interface fluid film. The solution of Reynolds and energy equations is obtained simultaneously. The change in fluid properties due to pressure field, p , and temperature field, T , is considered. The non-linearity introduced by the change in fluid film due to pressure surface elastic deformation, Δh , is coupled with the non-isothermal fluid film model via a partitioned fluid-structure interaction analysis, based on an outer fixed-point iteration scheme. The Reynolds equation is solved using a **Geometric Multigrid** algorithm to improve accuracy and performance.
- 2) **Solids Finite Element Heat Transfer Model:** this module calculates the solid bodies' temperature distributions. The conductive form of the energy equation is solved. Based on the heat fluxes due to viscous dissipation, Q_s , the temperature distribution of the solid parts, T_B , is predicted. The temperature distribution is used as more accurate surface temperature boundary, T_s , for the fluid film and to determine the thermal stress condition for the solid parts. High geometrical accuracy for the solid bodies is allowed through the **unstructured** discretization, which allows generating solid geometries directly from CAD software.
- 3) **Solids Finite Element Elastic Deformation Model:** this module allows determining the elastic deformation of the solid bodies due to external fluid film pressure and internal thermal loading. Two different methods are used according to the type of load. The solution of pressure surface elastic deformation is obtained using an influence method, running complete FEM analysis off-line. The solution of the thermal deformation is achieved running complete FEM analysis at run-time. The ultimate information provided by this numerical model is the total deflection of the bounding surface, Δh . FEM analysis based on CAD solid models coupled with the inclusion of advanced constraints methods, such as **Inertia Relief**, allows a very accurate prediction of the fluid film boundaries surface elastic deformations.

The model, validated through the comparison with several measurements, is used by Maha researchers to discover lubricating interface physical behavior and to study the energy dissipation through viscous friction and leakage flow.

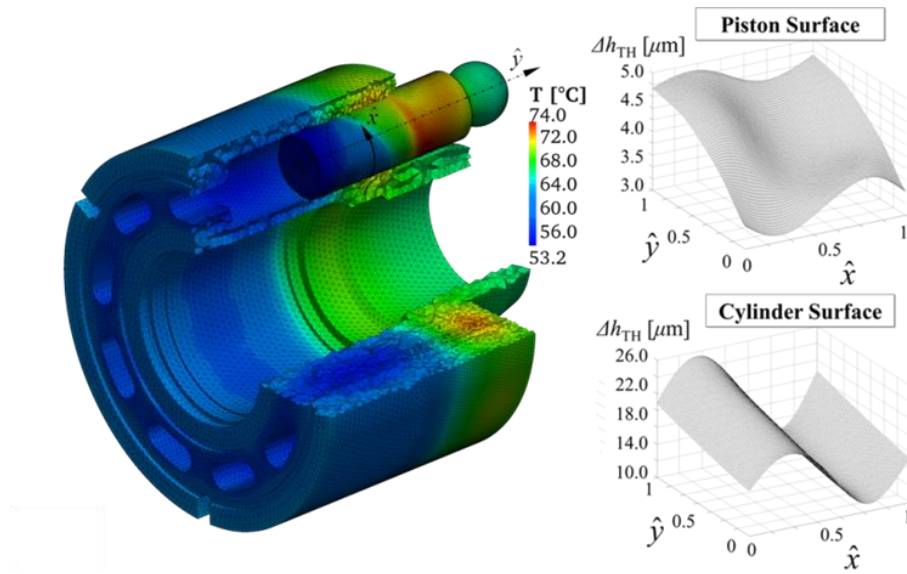

Fig. 19: Axial Piston Machine Piston/Cylinder Block Temperature Distribution (Left) and Surface Thermal Deformations for a High Load Operating Condition (Right)

Thermal expansion due to energy dissipation in the fluid film can lead to major changes of the fluid film thickness and shape. For pumps using a brass bushing pressed into the cylinder made from steel, these thermal expansions introduce a wavy surface shape that helps to improve the load carrying ability of the fluid film, as shown by Fig. 19. This explains why all pumps and motors working at extreme high pressures have to have a brass bushing in order to achieve a reliable operation and acceptable efficiency values.

This discovery together with the developed multi-physics model forms the starting point for a new computational based design approach. The model will be used to investigate better interface designs, including novel material combinations and shaped surfaces. These innovative interface designs will lead to better machine performance and increased efficiency over a wider range of operating conditions.

The slipper swashplate interface incorporates the effects of both pressure and thermal deformations. These deformations affect both the slipper and the swashplate running surfaces. Although the overall swashplate pressure deformation typically has magnitudes multiple times the fluid film thickness, because a single slipper only “feels” part of the deformation at one time the influence on overall operation varies. Fig. 20 highlights how all of these physical effects combine to enable successful lubrication of the slipper and swashplate.

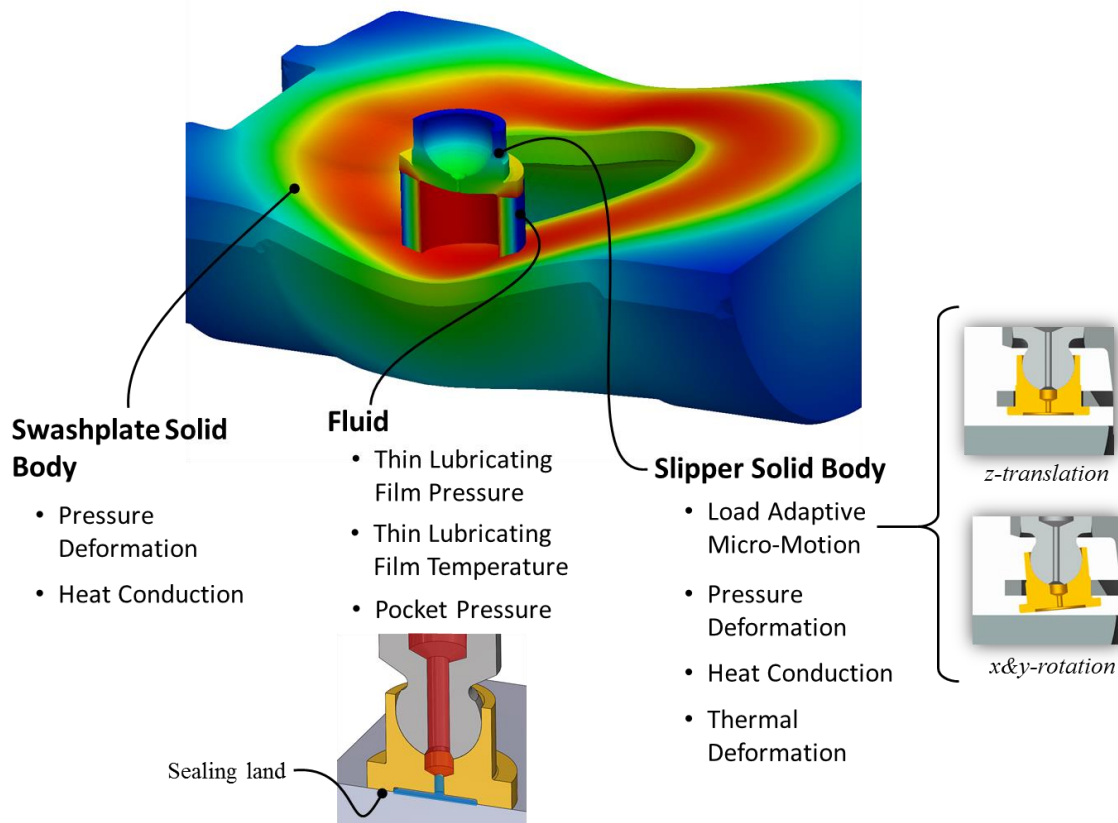

Fig. 20: Slipper/Swashplate Fluid-Structure-Thermal Interaction Model

Another important factor affecting the performance of all three lubricating interfaces is surface shaping occurring during the pump wear-in process. Slipper designs which exhibited frequent low fluid film thicknesses were prone to having microns of wear during the initial pump run-in process. These microns of wear on the inner or outer sealing land edges enable steady state full film lubrication. The stylus profilometer detailed in its respective section of this report has proven extremely valuable to validating the simulation results and actual lubricating surface wear.

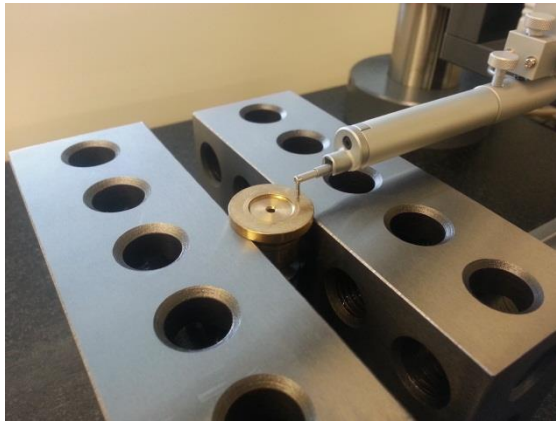

Fig. 21: Measuring Slipper Wear Using the Mitutoyo Stylus Profilometer

The cylinder block/valve plate interface was validated against test data this year. A pump was specially fitted with thermocouples arranged near the valve plate surface. Figure 22 compares the predicted temperatures for these locations based on simulation and the measured values. The level of agreement between the two temperature fields speaks to the validity of the modelling approach considering thermal and pressure deformation of the solid parts.

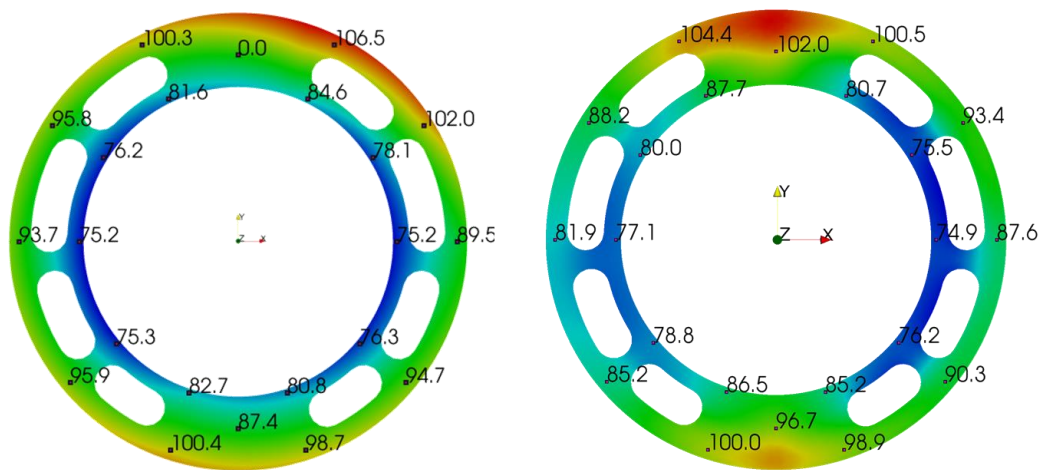

Fig. 22: Comparison of Measured (Left) and Simulated (Right) Temperature Distribution of the Valve Plate at 2000 rpm, 200 bar, and 50% Displacement.

New Micro-Surface Shapes Study

One of the main activities of the center towards the improvement of current swash plate type axial piston machines is the investigation of micro-surface shaping and novel material combination in relation to the

performance of the three main lubricating interfaces. The main goal is to achieve higher efficiency especially at low displacement and low pressure.

In 2008 the center had worked on the study of barrel and waved barrel like micro-surface shaping on the pistons surface. Also, in 2009 a wave like micro-surface shape was introduced on the piston's surface (Filed patent: 61/165, 661). In these cases, simulations had shown a potential improvement of up to 60% in total power loss. Most recently, the center has been investigating the impact of micro-surface shaping on the piston surface along with varying gap heights on the overall performance of the machine through a fully coupled fluid structure interaction model in which thermal deformation and elastic deformation is considered that was developed in the center. From this model that is able to provide much more accurate predictions along with a combination of various micro-surface shapes and a decrease in the clearance between the piston and cylinder, simulations have shown potential improvements of overall power loss up to 50% at full displacement and 65% at partial displacements at higher pressures and even still an improvement of up to 20% and 60% respectively at lower pressures. Also, minimum gap heights and areas of friction are being investigated to better understand what is occurring between the piston and cylinder allowing to even better improve the overall operation of the machine. In the future, simulation studies will lead to manufacturing prototypes and then testing will be done on both the Tribo and EHD test rigs to verify the simulation results. These results represent a major breakthrough in this research direction and suggest an even deeper study of the possible new technology.

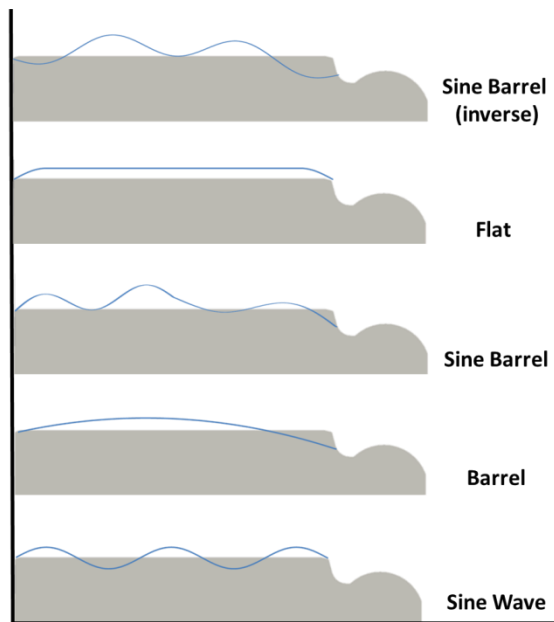

Fig. 23: Various Micro-Surface Shapes on the Piston Surface

Noise Control and Acoustics

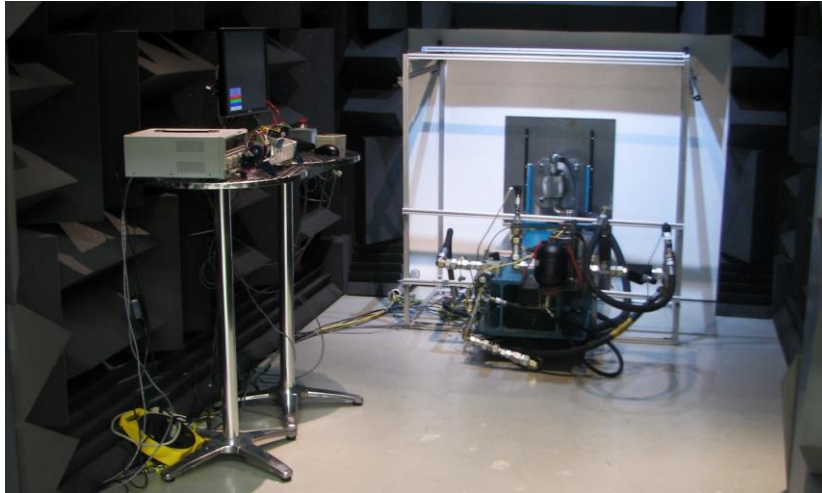

Fig. 24: Maha's Semi-Anechoic Chamber

The goal for this area of research is to understand the sources of noise within hydraulic systems. A fundamental understanding of noise generation for hydraulic systems will enable design of hydraulic components and systems. The use of complex hydraulic systems has led to the demand for a more comprehensive understanding of audible noise. The widespread use of axial-piston based hydraulic systems, within multiple industries, has motivated our research to center on the design of a pump/motor system.

The acoustic energy (Airborne Noise, ABN) emitted from the hydraulic system can be attributed to two main sources, namely, Fluid Borne Noise Sources (FBNS) and Structure Borne Noise Sources (SBNS). It is important that all projects consider both sources of noise.

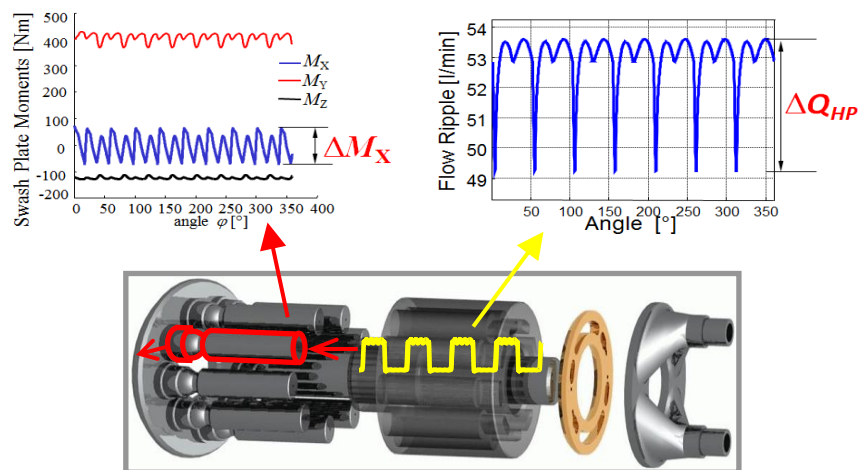

Fig. 25: Axial Piston Pump Showing the Fluid Borne and Structure Borne Noise Sources

VpOptim

The first approach aims to reduce noise generated by pumps and motors at the source level (FBNS and SBNS). Both Fluid Borne Noise Sources (FBNS) and Structure Borne Noise Sources (SBNS) are generated from the pressure changes in the displacement chambers. The most effective modification to a pump, in order to reduce noise sources, is a well-designed valve plate. VpOptim receives its name from optimizing the valve plate of a pump.

Designing a valve plate requires the designer to optimize multiple sources of noise simultaneously through the selection of several design input variables. VpOptim is therefore a multi-parameter multi-objective optimization procedure developed to reduce sources (FBNS and SBNS) of noises from pumps and motors which operate in a wide range of operating conditions.

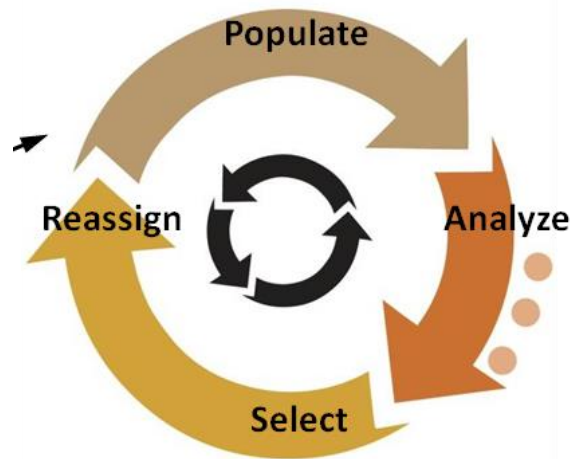

Fig. 26: Schematic of the Process Flow inside VpOptim

VpOptim enables a designer to optimize, independently, the relief grooves and pre/post compression filter volumes. The relief groove reduction technique is characterized by multiple design variables which influence the area between displacement chamber and the pump's external ports. This more precisely controls the change in pressure inside the displacement chamber. The pre-compression filter volume and post-compression filter volumes describe a volume of fluid attached to the displacement chamber to reduce noise. Both reduction techniques are inputs to VpOptim's Multi Objective Optimization algorithm to select a Pareto optimum set of relief grooves and/or Compression filter volumes which will have the minimum possible FBNS and SBNS over the selected range of operating conditions.

In the year 2013, there have been several improvements to VpOptim. In the effort to increase our understanding of a valve plate's influence on a pumps noise generation, we have increased the complexity of the valve plates. This included designing all 4 relief grooves on a valve plate to be unique. This enabled greater reductions in noise sources by allowing a greater flexibility of design. These more complicated designs were encourage through the additional work of implementing a new numerical solver that was 1,000 times faster than its predecessor.

TransModel

The second approach aims to reduce the noise generation at the system level. The system chosen here is a hydrostatic transmission which employs pumps and motors usually running at varying displacements, speeds and pressure levels. Simulation software (TransModel) has been developed which includes a time-domain model of the transmission coupling the pump and the motor using a line. In particular, a time domain line model is necessary to couple time domain dynamic pump and motor models. TransModel has the capabilities to investigate different factors such as rotating group design and hose dimensions which have an effect on the overall noise of the system.

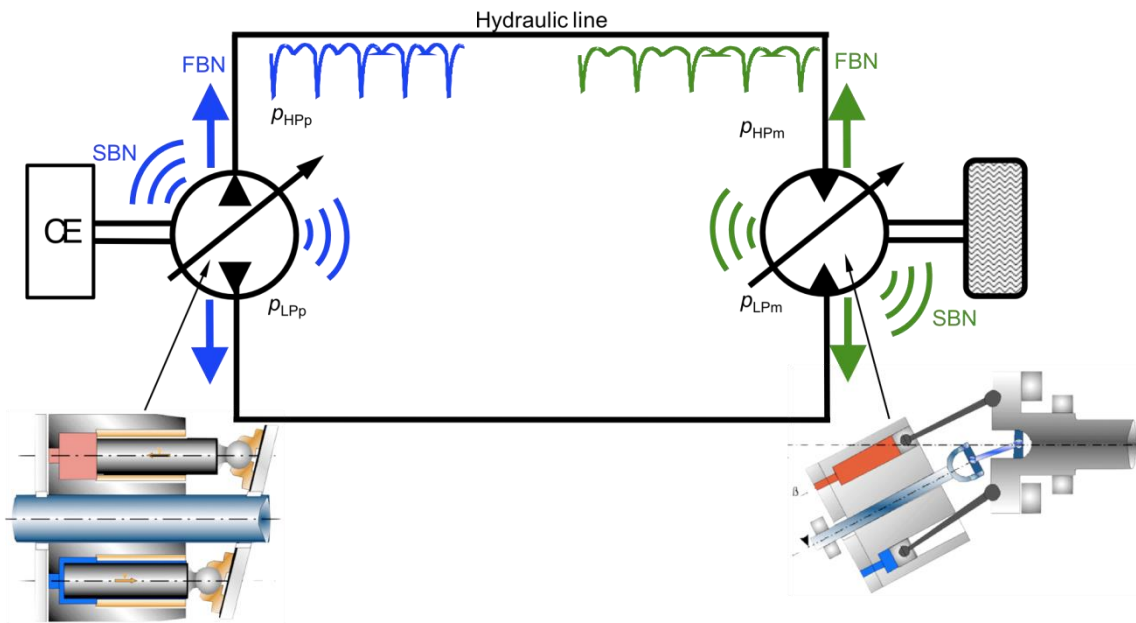

Fig. 27: Schematic of hydrostatic transmission implemented in TransModel

The line model chosen solves the continuity and momentum equations based on the partial differential equation technique, method of characteristics. This approach is selected because superimposed pressure and

flow pulsations can be predicted and both noise sources (FBNS and SBNS) are quantified. Fluid borne noise source (FBNS) is quantified by calculating instantaneous pressure and flow ripples throughout the HP line between the pump and motor. Structure borne noise source (SBNS) is characterized by calculating instantaneous swash plate moments in all directions, for both units.

2 Research Facilities



Lab Space and Test Rigs at Maha
The lab currently houses ten test rigs designed to support our research.

Test Beds for Technological Demonstration (Above)

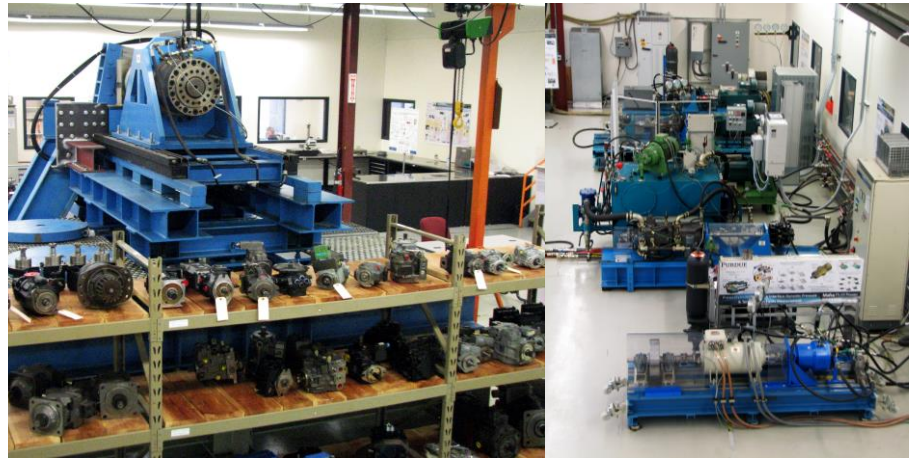

Test Rigs and Assembly Area (Above)
and Control Room (Left)

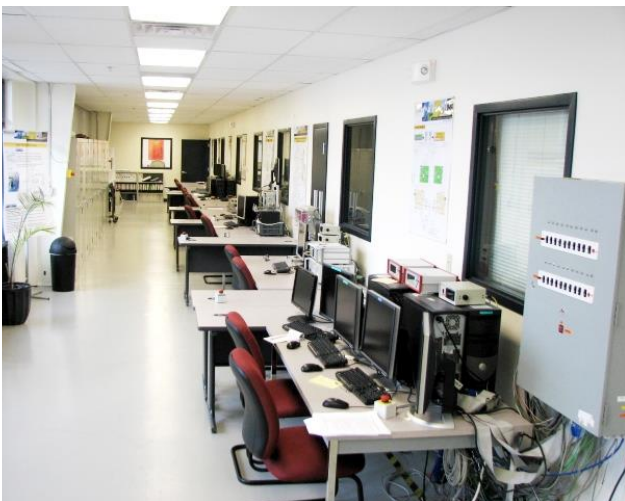



EHD Test Rig

The EHD test rig is designed to measure the dynamic pressure field in the gap between piston and cylinder and the surface temperature distribution in the cylinder of a swash plate axial piston pump. A special test pump with a single piston cylinder assembly has been designed for this test rig.

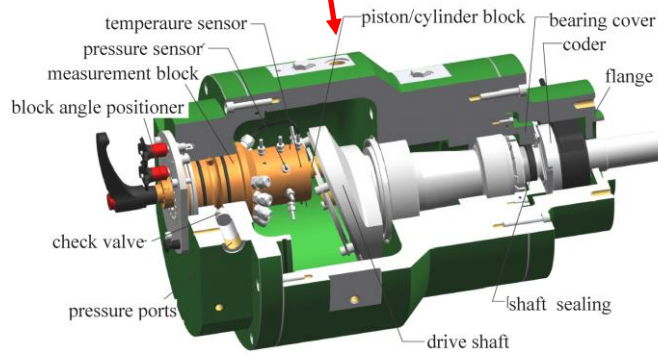

EHD Pump

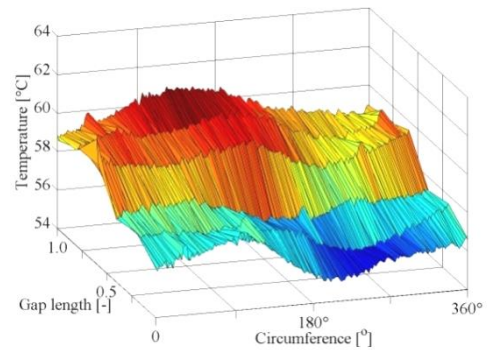

Measured Temperature Field in the Piston/Cylinder Gap



OLEMS Test Rig

This rig is designed to investigate the temperature behavior in swash plate axial piston pumps. Sixty thermocouples are mounted around a single cylinder to measure the temperature field during operation of the pump. Telemetry is used for data transfer from the rotating cylinder block to the data acquisition board. The measured results are used for the development of a more precise method to calculate the non-isothermal gap flow between piston and cylinder in swash plate type axial piston machines.

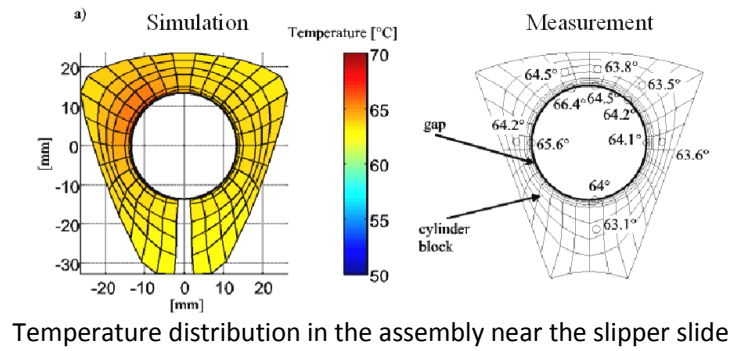
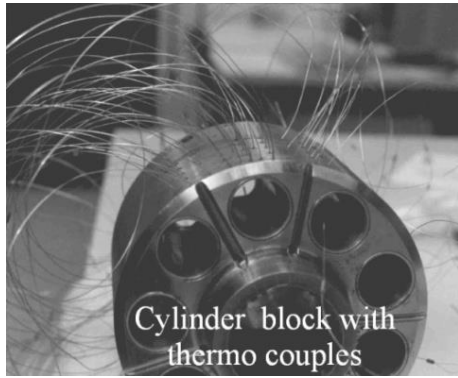

Tribo Test Rig

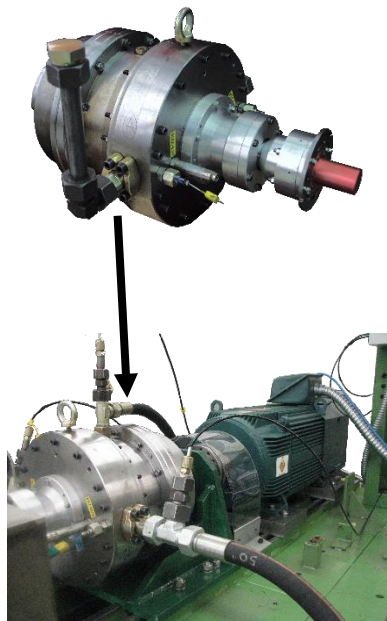

The heart of the test rig, the Tribo pump (below, left), is designed to measure the dynamic axial and circumferential friction forces between the piston and cylinder. Data is transmitted wirelessly from the rotating kit to a data acquisition via a telemetry system. The Tribo pump can be operated in either pumping or motoring mode at speeds up to 1800 rpm. Measurements can be taken during steady state conditions at different oil viscosities.

The Tribo test stand has been fitted with a new variable speed electric drive motor (above, left). This change enables improvements to the hydraulic circuit allowing much closer control over fluid temperature. Much of the data acquisition and control hardware has also been updated.

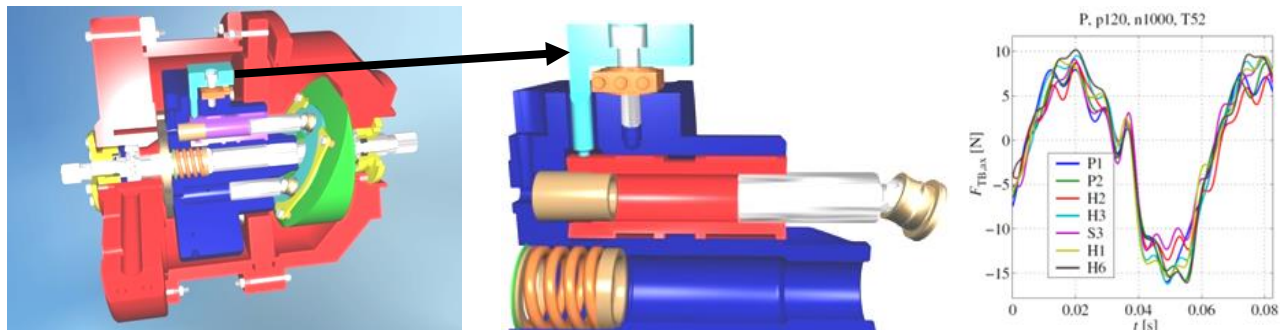



Cavitation/PIV Test Rig

This test rig was designed to visualize and conduct Particle Image Velocimetry (PIV) analysis of cavitation in hydraulic oil. This test rig was designed in support of CCEFP project 3C and will support the computational studies in modeling cavitation in hydraulic components.



Transmission Test Rig

The test rig is designed to determine the efficiency of a hydrostatic car transmission at different loads and gear ratios. The transmission is driven by a diesel engine and a secondary controlled unit simulates the driving resistance of the vehicle.

Test Rigs for Steady State Measurements

Two electric motor driven test rigs have been designed to measure steady state and dynamic characteristics for different pump and motor types including 1 rpm tests. The test rigs are equipped with temperature and pressure sensors as well as speed, flow and torque meters.

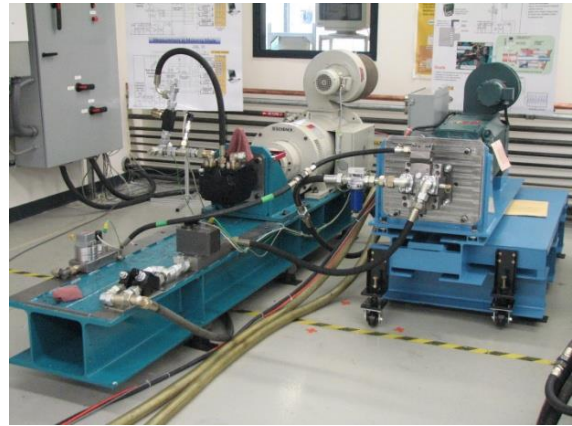

Performance Characteristics

Max. installed electric power: 2 x 120 kW

Max. speed: $n_1 = 7000$ rpm/ $n_2 = 3000$ rpm

Max. pressure: 450 bar

Max. torque: $M_1 = 300$ Nm/ $M_2 = 500$ Nm

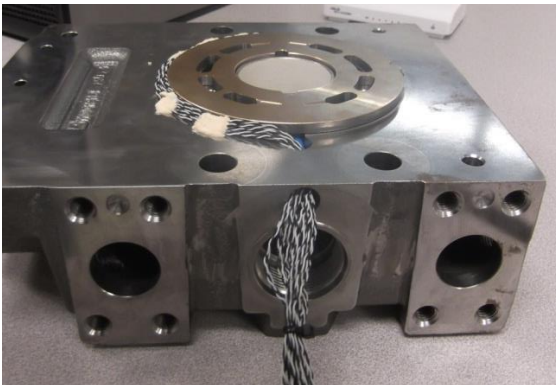

Thermo-Pump

Modifications made to fit 22 K-type thermocouples right below the surface of the valve plate. Measurements taken on the steady state measurement test rig to verify model predictions.



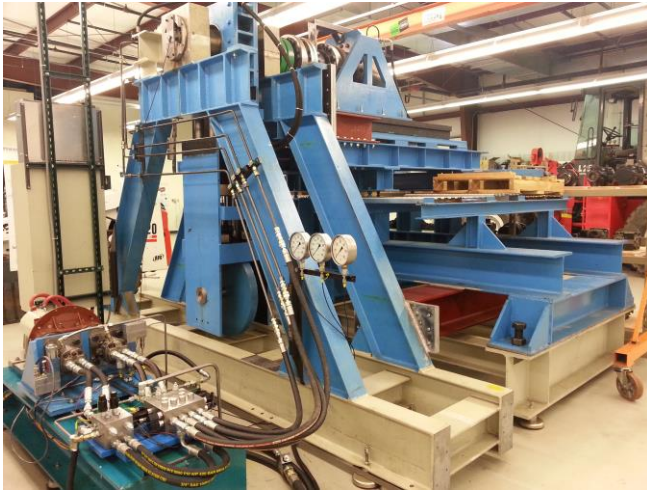

JIRA Test Rig

The joint integrated rotary actuator test rig (JIRA) was originally built for the experimental investigation of displacement controlled rotary actuators. The ideas and technologies developed for and implemented in this test rig have been utilized as end effector drives in mobile robots and large manipulators as well as for applications such as stabilizers in cars or ships.

Performance

Max. Torque: 30000 Nm

Max. Pressure: 350 bar

Max. Power: 30 kW

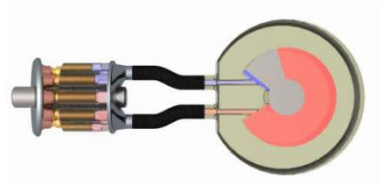

Rotary Actuator

Recent improvements on the test rig have allowed for the demonstration of pump switching for the sequential operation of multiple actuators. This technology not only reduces the installed pump power but increases overall efficiency by reducing parasitic losses. In addition to the hardware improvements, new control concepts focused on actuator operability have been developed. Research is in progress to investigate the applications and limitations of these new hydraulic architectures and control strategies.

Semi-Anechoic Chamber

A semi-anechoic hydraulic transmission test facility is available in Maha Fluid Power Research Center to measure the sound power radiated from the sources. The facility enables the investigation of noise levels for different designs of displacement units and transmissions. The facility has the capabilities to use two electrical units which are used as electric motor/generator combination. These two electrical units are coupled with hydraulic displacement units to recreate an entire hydrostatic transmission.

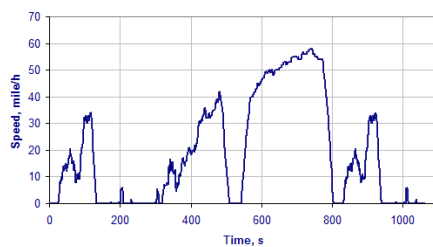
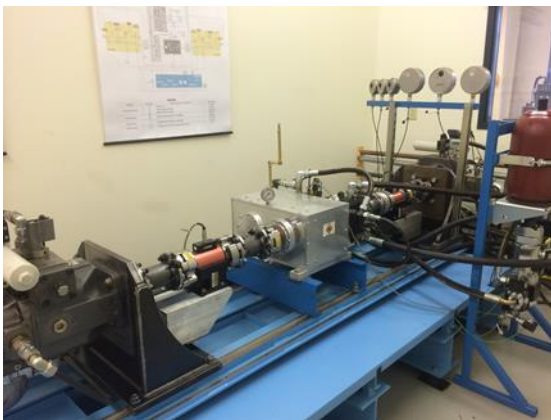
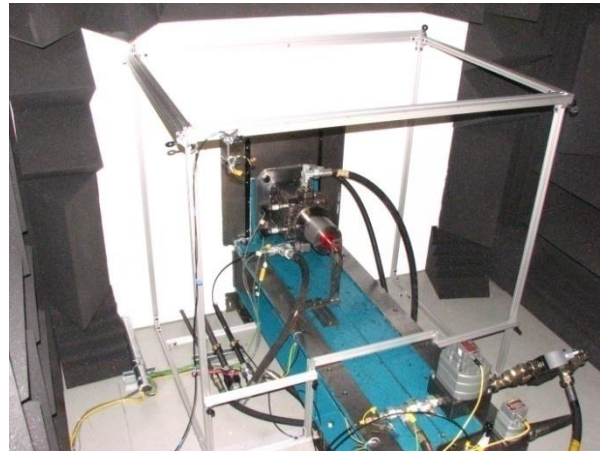

Power Train Test Rig

This test rig has been designed for the purpose of testing power trains and power train control concepts developed here at the Maha lab. A hydraulic motor supplies input shaft power to the power train being tested, while a hydraulic pump creates a simulated load at the output shaft of the power train. Pictured is a series hydraulic hybrid transmission intended for use in a Toyota Prius. The test rig can be used to accurately simulate given drive cycles such as the UDDS drive cycle shown below.

Hydraulic Power Supply

The above test rigs are powered by a 320 kW central hydraulic power supply unit with a 2000 liter tank, a water cooler and heating elements with five individually controlled pressure compensated pumps, 350 bar and 450 lpm output flow and a 60 l/min low pressure installed in 2005. A second medium pressure 63 kW hydraulic power supply, with a maximum flow rate of 250 l/min and pressure differential of 60 bar, has also been added. This supply is equipped with a 300 liter tank. The central pressure net is mainly used to supply hydraulic load units for the individual test rigs, where the load units are based on secondary control. The total installed electric power amounts to 1200 kW.



Surface Profilometer for Investigating Micro-surface Waviness and Wear

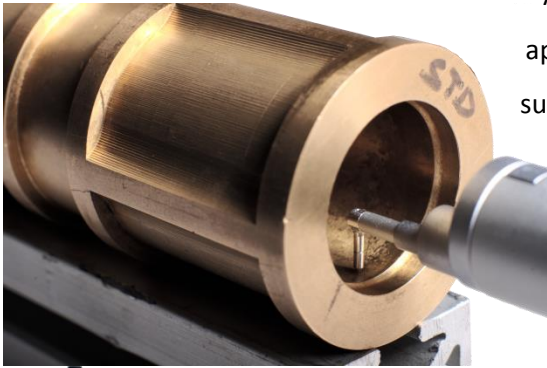

Axial piston pumps and motors are found in a wide range of applications, from aerospace to construction. Key to the successful operation of these machines are thin lubricating fluid films which separate the moving solid parts, preventing wear and reducing friction. Without this proper lubrication, the hydraulic pumps and motors would fail rapidly. Although the lubricating films are necessary to prevent catastrophic failure,

they also represent the largest source of power loss inside the hydraulic units. The Maha lab has been developing state-of-the-art numerical models to further understand the physics enabling the lubrication films and proposing new design methods to reduce the power loss coming from these fluid gaps.



The Maha lab in 2011 acquired a Mitutoyo stylus surface profilometer to allow for further investigation on the impact of micro-surface shaping and wear inside hydraulic pumps and motors. The profilometer is able to measure the change in height of a specimen with excellent resolution ($\sim 0.01 \mu\text{m}$) as the stylus slowly traverses in a straight line. As mentioned above, the critical lubricating fluid films are only microns thick; small deviations of the solid bodies either due to wear or manufacturing will significantly alter the development of the lubrication films. 2012 saw the further acquisition of a measurement stand for the profilometer which can be seen in the photo, allowing for the repeatable measurement of a wide array of part surfaces.

Variable-slope linear wear profile over slipper was assumed



Measured wear matched prediction

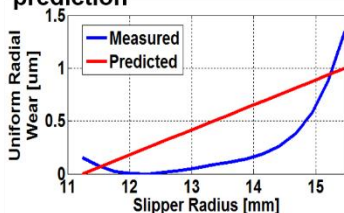

Fig. 28: Slipper Wear Study

The value of the profilometer system was demonstrated on several occasions during the past year. One slipper/washplate interface study assumed a simplified linear wear-in profile and found the slope which resulted in the best simulated performance. Then parts from a physical pump were measured using the profilometer showing good agreement with the predicted profile as pictured in Fig 28. The system has also aided the precision assembly of sensors in a prototype test rig. The profilometer

system continues to be useful not only as a source of simulation inputs, but also as a means of validating simulation outputs. In both ways, it is helping refine the models developed at the Maha lab.

Maha Computing Cluster

As the fidelity and complexity of numeral models developed and used at the Maha lab increase, so do the computational demands. Design of experiment studies compound the problem by requiring a single numerically expensive simulation to be run hundreds or thousands of times over in order to analyze the sensitivity and effect of system architecture or design parameter changes. Some of the studies conducted at Maha over the past year would have required hundreds of weeks of simulation time on the individual's desktop computer – a simply unacceptable burden. To solve this problem a set of new computers exclusively for simulation were purchased in 2010 and then further expanded in 2011 to total 16 machines. The computers feature i7 (4-real, 4-hyperthreaded core) processors, 12 GB ram, and 7200k hard disks with 100 Mbps Ethernet. Windows 7 x64 is installed on all machines which enables interactive use of each machine through Windows remote desktop for GUI only applications. In 2012 a Dell PowerEdge R815 server with Quad AMD Opteron processors and 128 GB ram was installed into the computing cluster. This new machine enables large in-core matrix simulations and 64 core shared-memory parallel simulations when necessary; when the large single machine capabilities are not required, the computer is easily partitioned using the HTCondor software described below. The simulation machines are networked together on a private LAN and can only be accessed remotely through a secure VPN. A custom in-house developed software suite allows monitoring the status and interactive use of each machine by every Maha member quickly through a simple web interface as illustrated below:

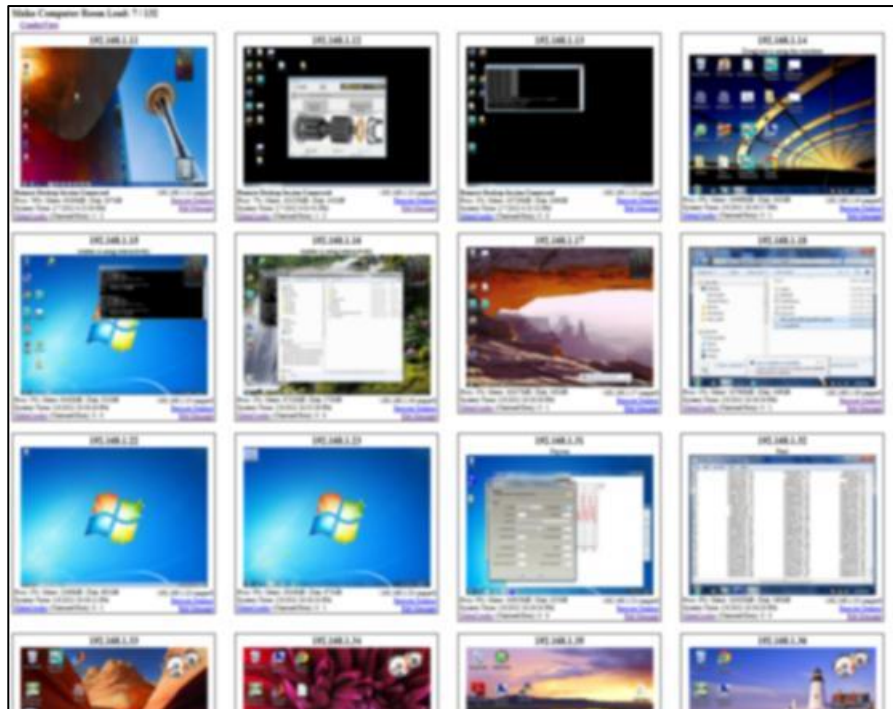

Beyond interactive use, HTCondor (<http://research.cs.wisc.edu/htcondor/>) a job management and scheduling system, is installed on all of the computers. This allows for a large queue (1000's of jobs) of command-line only programs to be submitted and scheduled at a head node. HTCondor handles the burden of input file transfer to each worker node, execution of the program, and the retrieval of simulation output back to the submit node. Using this system, hundreds of simulations can be performed in parallel with maximum throughput requiring little effort from the end user – something unfeasible just using remote desktop. The HTCondor head node in the Maha compute cluster runs Debian Linux which enables simple multi-remote user functionality and also fulfills network router, VPN, file and web server roles.

Test Beds

In addition to the stationary test rigs, the Maha Fluid Power Research Center also houses several vehicles that either have been used or are being used currently as platforms for demonstrating and/or investigating new fluid power systems concepts.



Wheel Loaders

Displacement control, the concept of controlling hydraulic actuators with variable displacement pumps instead of throttling valves, was first tested and demonstrated on the boom and bucket functions of this 25-ton front wheel loader.

The smaller 5-ton wheel loader originally served as a platform for diagnostics and prognostics on hydraulic systems. In 2013, it was overhauled to implement a displacement controlled steer-by-wire system.





Skid-Steer Loader

Pump-controlled technology has been demonstrated on compact machinery at the Maha Fluid Power Research Center. For the purpose of demonstrating active vibration damping through displacement control, a Bobcat skid-steer loader was modified. Previous Maha researchers have implemented active vibration damping using linear control theory. Recently, the skid-steer loader has been equipped with new electronics to add data acquisition and control capabilities. In addition, advanced control strategies are currently being researched to improve our already existent active vibration damping algorithms.

Mini Excavator

In early 2013, the transition from a non-hybrid architecture utilizing pump-controlled actuation for all working functions to a hydraulic hybrid architecture utilizing a series-hybrid swing drive was completed (while maintaining pump-controlled actuation for the other functions) on a 5-t mini excavator. With this, the world's first hydraulic hybrid excavator of its kind was realized at the Maha Fluid Power Research Center.

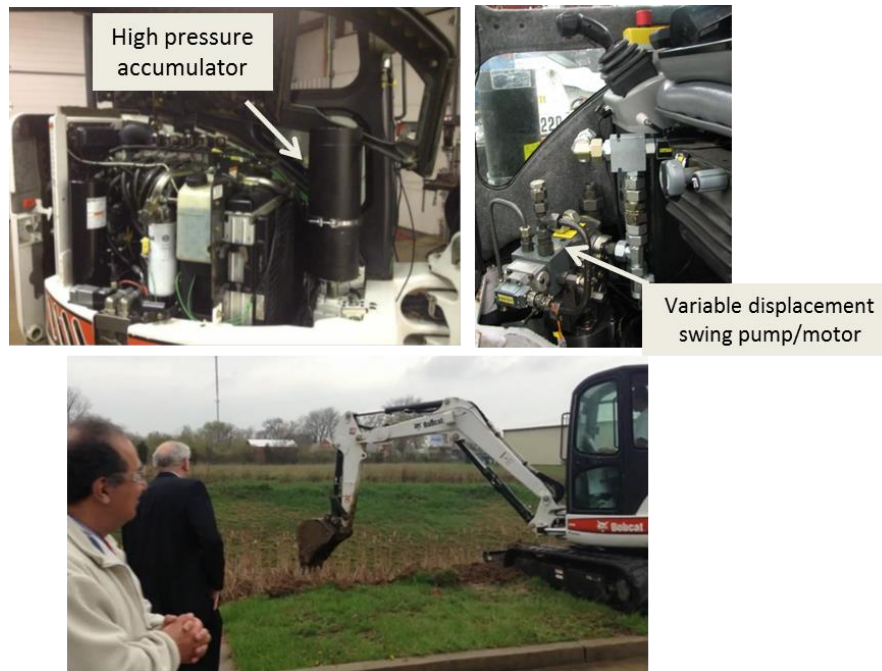

The hybrid excavator was demonstrated in action to the Site Visit team from the NSF Center for Compact and Efficient and Fluid Power (CCEFP) in April, 2013. The mini-excavator has served as Test-Bed 1 of the CCEFP, since the center's inception in 2006.

The excavator employs closed-loop speed control for the motion of the swing drive. Energy management strategies were also implemented on the test-bed toward the end of 2013 – (a) demonstrating the capacity of the novel hydraulic hybrid architecture to enable up to 50% engine downsizing, while still meeting aggressive digging cycles (which represent peak power demands from the excavator), and (b) exploiting varying engine speeds to achieve near-optimal behavior for such hybrid systems (with 50% engine power). Measurement results from these are documented earlier in the report.

The excavator will serve as a platform to demonstrate pump-switching architectures and relevant controls concepts in 2014.

3 Research Grants

Research Grants obtained in 2013: \$2,179,208

Public Funding: \$ 1,648,328

Engineering Research Center (ERC) for Compact and Efficient Fluid Power (CCEFP). NSF + affiliated-industry funds, 8th year funding \$995,515, USDA, and Maha funds

Funding from new industry projects: \$ 464,880

- Advanced Energy Saving Hydraulic System Architecture and Control
- Analysis of Pump Noise Sources & Design Optimization
- Pump Design Optimization through Fluid Structure Interaction Modeling
- Hydraulic Motor Design study & Measurements

4 Publications, Invited Lectures, Patents, and Reports

Journal Articles

Busquets, E. and Ivantysynova, M. 2013. "Temperature Prediction of Displacement Controlled Multi-Actuator Machines." *International Journal of Fluid Power*. Vol. 14, No. 1, pp. 25 - 36.

Pelosi, M. and Ivantysynova, M. 2013. "The Impact of Axial Piston Machines Mechanical Parts Constraint Conditions on the Thermo-Elastohydrodynamic Lubrication Analysis of the Fluid Film Interfaces." *International Journal of Fluid Power*, Vol. 14, No. 3, pp. 35-51

Daher, N. and Ivantysynova, M. (2013). "An Indirect Adaptive Velocity Controller for a Novel Steer-by-Wire System." *ASME Journal of Dynamic Systems, Measurement, and Control*. Manuscript No. DS-13-1469 (in review).

Daher, N. and Ivantysynova, M. (2013). "A Virtual Yaw Rate Sensor for Articulated Vehicles Featuring Novel Electro-Hydraulic Steer-by-Wire Technology." *Control Engineering Practice*. Manuscript No. CONENGPRAC-D-13-00575 (in review).

Daher, N. and Ivantysynova, M. (2013). "Energy Analysis of an Original Steering Technology that Saves Fuel and Boosts Efficiency." *Energy Conversion and Management*. Manuscript No. ECM-D-13-02163 (in review)

Conference Proceedings

Daher, N. and Ivantysynova, M. 2013. "Pump Controlled Steer-by-Wire System." *SAE 2013 Commercial Vehicle Engineering Congress*, Oct. 1-3 2013, Rosemont, IL, USA. SAE Technical Paper 2013-01-2349. **-2013 SAE Excellence in Oral Presentation Award**

Daher, N. and Ivantysynova, M. 2013. "System Synthesis and Controller Design of a Novel Pump Controlled Steer-By-Wire System Employing Modern Control Techniques." *ASME/Bath Symposium on Fluid Power and Motion Control*, Oct. 6-9, 2013, Sarasota, FL, USA. Paper No. FPMC2013-4410

Schenk A., Zecchi M. and Ivantysynova, M. 2013. "Accurate Prediction of Axial Piston Machine's Performance Through a Thermo-Elasto-Hydrodynamic Simulation Model." ASME/Bath Symposium on Fluid Power and Motion Control, Oct. 6-9, 2013, Sarasota, FL, USA. Paper No. FPMC2013-4456

Zecchi, M. and Ivantysynova, M. 2013. "Spherical Valve Plate Design in Axial Piston Machines - A Novel Thermo-Elasto-Hydrodynamic Model to Predict the Lubricating Interface Performance." The 8th International Conference on Fluid Power Transmission and Control (ICFP 2013), Apr. 9-11, 2013. Hangzhou, China, pp. 325 – 329

Daher, N. and Ivantysynova, M. 2013. "Novel Energy-Saving Steer-by-Wire System for Articulated Steering Vehicles: A Compact Wheel Loader Case Study." Proceedings of the 13th Scandinavian International Conference on Fluid Power (SICFP2013). Jun. 3-5, 2013. Linköping, Sweden.

Hippalgaonkar, R. and Ivantysynova, M. 2013. "A Series-Parallel Hydraulic Hybrid Mini-Excavator with Displacement Controlled Actuators." Proceedings of the 13th Scandinavian International Conference on Fluid Power (SICFP2013). Jun. 3-5, 2013. Linköping, Sweden.

Sprenkel, M. and Ivantysynova, M. 2013. "Investigation and Energetic Analysis of a Novel Hydraulic Hybrid Architecture for On-Road Vehicles." Proceedings of the 13th Scandinavian International Conference on Fluid Power (SICFP2013). Jun. 3-5, 2013. Linköping, Sweden.

Zecchi, M., Mehdizadeh A. and Ivantysynova, M. 2013. "A Novel Approach to Predict the Steady State Temperature in Ports and Case of Swash Plate Type Axial Piston Machines." Proceedings of the 13th Scandinavian International Conference on Fluid Power (SICFP2013). Jun. 3-5, 2013. Linköping, Sweden.

Sprenkel, M. and Ivantysynova, M. 2013. "Control Strategies for a Novel Blended Hydraulic Hybrid Transmission." Proceedings of the 22nd International Conference on Hydraulics and Pneumatics. Oct. 24-25, 2013. Prague, Czech Republic, pp. 15-22

Busquets, E. and Ivantysynova, M. 2013. "Thermal-hydraulic Behavior Prediction of a Valve Controlled Wheel Loader." Proceedings of the 22nd International Conference on Hydraulics and Pneumatics. Oct. 24-25, 2013. Prague, Czech Republic, pp. 23-31

Invited Lectures

Ivantysynova, M. 2013. "The Secret of the Fluid Film in Piston Machines." The 8th International Conference on Fluid Power Transmission and Control (ICFP 2013), Apr. 9-11, 2013. Hangzhou, China **-Keynote Lecture**

Ivantysynova, M. 2013. "Displacement Control Actuation Future and Challenges of Fluid Power." Beihang University - Workshop on Fluid Power Systems, Apr. 11, 2013. Beijing, China **-Keynote Lecture**

Ivantysynova, M. 2013. "Fuel Savings through Hydraulic Hybrid System Technology." Joint ASABE / SAE Meeting, Jun. 19, 2013. Chicago, IL, USA

Ivantysynova, M. 2013. "Displacement Control & Hydraulic Hybrids - Future of Fluid Power." Evonik Global Hydraulic Segment Meeting, Jul. 9, 2013. Philadelphia, PA, USA

Patents Awarded

US patent No. 8,454,469 issued June 4, 2013. Power Split Transmission with Energy Recovery. (Ivantysynova, M., Carl, B. and Williams, K.)

US patent No. 8,453,441 issued June 4, 2013. System and Method for Pump-Controlled Cylinder Cushioning. (Ivantysynova, M. and Williamson, C.)

U.S. Patent No. 8,474,254 B2 issued July 2, 2013: System and Method for Enabling Floating of Earthmoving Implements. (Ivantysynova, M. Hughes, E., Williamson, C. and Zimmerman, J.)

Research Reports

Sprengel, M. and **Ivantysynova, M.** 2013. "Testing Overview and Measurement Data Explanation." Maha Fluid Power Research Center. Research Report MAHA01-2013-ex

Sprengel, M. and **Ivantysynova, M.** 2013. "Reach Stacker Simulation Overview." Maha Fluid Power Research Center. Research Report MAHA02-2013-ex

Spencer, N. 2013. "Disassembling/Reassembling Sauer H1 Pump." Maha Fluid Power Research Center. Research Report MAHA03-2013-in

Spencer, N. 2013. "Taking Steady State Test Rig Measurements." Maha Fluid Power Research Center. Research Report MAHA04-2013-in

Spencer, N. 2013. "Finding Slipper/Swashplate Convection Coefficient using Acusolve." Maha Fluid Power Research Center. Research Report MAHA05-2013-in

Hippalgaonkar, R. and Ivantysynova, M. 2013. "Hybrid Excavator Swing Drive Simulation." Maha Fluid Power Research Center. Research Report MAHA06-2013-ex

Chacon, R. 2013. "Nonlinear Contact Analysis." Maha Fluid Power Research Center. Research Report MAHA07-2013-in

Schenk, A. and Zecchi, M. 2013. "Mobil DTE 10 Excel 32 Oil Measurements." Maha Fluid Power Research Center. Research Report MAHA08-2013-in

Zecchi, M. and Ivantysynova, M. 2013. "Mobil DTE 10 Excel 32 Oil - Mathematical Model." Research Report MAHA09-2013-ex

Sprenkel, M. and Ivantysynova, M. 2013. "Effect of Various Oils on the Efficiency of a Series Hydraulic Hybrid Transmission." Maha Fluid Power Research Center. Research Report MAHA10-2013-ex

5 Theses Completed In 2013

PhD Theses

Marco Zecchi 2013. "A Novel Fluid Structure Interaction and Thermal Model to Predict the Cylinder Block/Valve Plate Interface Performance in Swash Plate Type Axial Piston Machines." PhD Thesis, Purdue University.

Master's Theses

Enrique Busquets 2013. "An Investigation of the Cooling Power Requirements for Displacement-Controlled Multi-Actuator Machines." Master's Thesis, Purdue University.

6 International Co-operation

Every year, the Maha lab is pleased to host international scholars for a period of some months. Our successful international co-operations with fluid power research centers worldwide has been strengthened through our membership in the international network “Fluid Power Net International” (FPNI), which is currently joined by members from 26 countries, refer to <http://fluid.power.net>

International Students and Researchers

In 2013, the following international students and researchers have worked in our team



Bjoern



Hong



Jose



Yizhu



Amin

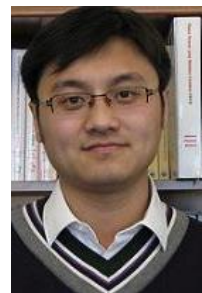

Wei



Hideaki

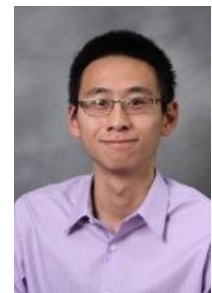

Yangqiao

Bjoern Bahl Germany
Dr. Hong Gao China
Jose Edgar Gomez Mexico
Yizhu Gu China

Amin Mehdizadeh Iran
Wei Shen China
Hideaki Usami Japan
Yangqiao Zheng China

7 International and National Conferences Attended

8th International Conference on Fluid Power Transmission and Control

April 9-11, 2013. Hangzhou, China.

Attendees:

Monika Ivantysynova (**Keynote Lecture**)

Marco Zecchi (Paper Presentation)

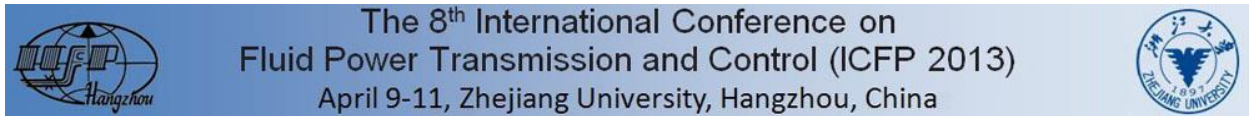

Beihang University – Workshop on Fluid Power Systems

April 11, 2013. Beijing, China.

Attendees:

Monika Ivantysynova (**Keynote Lecture**)



13th Scandinavian International Conference on Fluid Power

June 3-5, 2013. Linköping, Sweden.

Attendees:

Monika Ivantysynova

Naseem Daher (Paper Presentation)

Rohit Hippalgaonkar (Paper Presentation)

Michael Sprengel (Paper Presentation)

Marco Zecchi and Amin Mehdizadeh (Paper Presentation)

SICFP 2013

Linköping
3-5 June

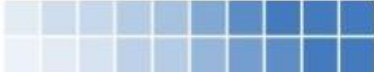

"Controlling the Future"

Joint ASABE / SAE Meeting

June 19, 2013. Chicago, IL, USA.

Attendees:

Monika Ivantysynova (**Invited Lecture**)



Evonik Global Hydraulic Segment Meeting

July 9, 2013. Philadelphia, PA, USA.

Attendees:

Monika Ivantysynova (**Invited Lecture**)



EVONIK
INDUSTRIES

SAE 2013 Commercial Vehicle Engineering Congress

October 1-3, 2013. Rosemont, IL, USA.

Attendees:

Naseem Daher (Paper Presentation, **Excellence in Oral Presentation Award**)



ASME/Bath Symposium on Fluid Power and Motion Control

October 6-9, 2013. Sarasota, FL, USA.

Attendees:

Monika Ivantysynova

Naseem Daher (Paper Presentation)

Andrew Schenk and Marco Zecchi (Paper Presentation)



22nd International Conference on Hydraulics and Pneumatics

October 24-25, 2013. Prague, Czech Republic.

Attendees:

Enrique Busquets (Paper Presentation)

Michael Sprengel (Paper Presentation)



8 Maha Hosted & Organized Events

Maha Hosting the 2013 NSF Site Visit of CCEFP

This year's NSF Site Visit of the National Science Foundation Engineering Research Center for Compact and Efficient Fluid Power (CCEFP) took place at Purdue University on April 22-25, 2013. The CCEFP leadership team, the site visit team, 10 university administrators, 4 members of the scientific advisory board, 12 industrial advisory board representatives, 21 faculty and researchers, along with 50 graduate students were greeted with a welcome dinner at a local restaurant downtown Lafayette, Lafayette Brewing Company, on the first evening of their visit. The next morning, participants were welcomed by the Provost of Purdue



Welcoming by Purdue Provost Timothy Sands

University Timothy D. Sands. Following were presentations of Test Bed 1: Mobile Heavy Equipment – High Efficiency Excavator, Test Bed 3: Highway Vehicles – Hydraulic Hybrid Passenger Vehicle, Test Bed 4: Mobile Human Scale Equipment – Hydraulic Patient Transfer Device, and Test Bed 6: Human Assist Device – Fluid Power Assisted Orthosis respectively. After the presentations were concluded, participants of the event attended a lab tour of Maha in which the graduate students presented their research along with some machine demonstrations followed by a nice dinner party at lab. The final day of the conference included presentations of Industrial Collaboration and Sustainability and was concluded with a poster session that featured individual research projects. This unique opportunity allowed Maha both to represent Purdue University and to display the achievements accomplished during 7 years-to-date of NSF and CCEFP funding.

Poster Session



Presentations



Lab Tour

Part of the NSF Site Visit was a tour of the Maha Fluid Power Research Center. This allowed more than 130 people to tour our lab on the afternoon of Tuesday, April 23. Maha graduate students presented the lab's test rigs and their research projects to the NSF Site Visit team, the Industrial Advisory Board, and all other guests and members of the CCEFP. One of the highlights of the lab tour was a live demonstration of the CCEFP Test Bed 1, the displacement controlled mini excavator with its new hydraulic hybrid architecture for the swing drive. This machine allows



Test Bed 1 Demonstration

for a 50% downsizing of the engine while saving more than 50% fuel compared to best-available current designs. This machine represents the world's first of its kind.

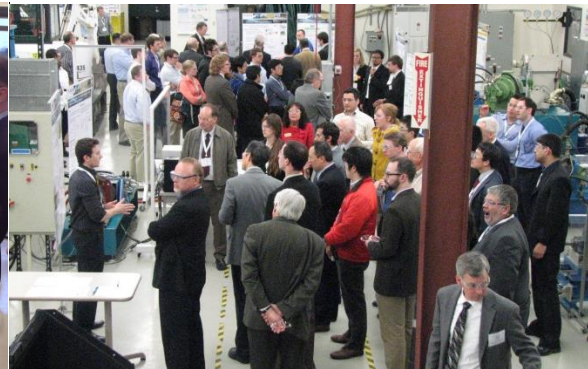

Site Visit Team During the Lab Tour

Dinner Party at Maha



More about CCEFP

The Center for Compact and Efficient Fluid Power (CCEFP) is a network of researchers, educators, students and industry working together to transform the fluid power industry—how it is researched, applied and studied. Center research is creating hydraulic and pneumatic technology that is compact, efficient, and effective. The CCEFP’s education and outreach program is designed to transfer this knowledge to diverse audiences—students of all ages, users of fluid power and the general public.

The CCEFP is a National Science Foundation Engineering Research Center, established in June 2006. In addition to its grant from NSF, the Center is supported by its seven participating universities and more than 50 industrial partners.

Purdue University is one of the seven universities represented in the CCEFP. The other participating universities are the Georgia Institute of Technology, the University of Illinois at Urbana-Champaign, the University of Minnesota, Milwaukee School of Engineering, North Carolina A&T State University, and Vanderbilt University.

Dr. Monika Ivantysynova sits on the executive committee of the CCEFP. She is the leader of Thrust Area 1: Efficiency, leading two projects - Project 1A.2: Control and Prognostics for Hybrid Displacement Control Systems and Project 1B.1: Next Steps towards Virtual Prototyping of Pumps and Motors. She also oversees Test Bed 1: Mobile Heavy Equipment – High Efficiency Excavator.

Currently there are three Purdue faculty members as well as their graduate student teams participating in the CCEFP: Monika Ivantysynova, Andrea Vacca, and John Lumkes.

CCEFP Leadership Team

Kim Stelson (University of Minnesota) – CCEFP Director

Perry Li (University of Minnesota) – CCEFP Deputy Director

Bar Bohlmann (University of Minnesota) – Sustainability Director

Wayne Book (Georgia Institute of Technology) – CCEFP Faculty, Thrust Area 3 Leader

Mike Gust (University of Minnesota) – Industrial Liaison Officer

Don Haney (University of Minnesota) - Communications

Monika Ivantysynova (Purdue University) – CCEFP Faculty, Thrust Area 1 Leader

Gary Williams (University of Minnesota) – IT Coordinator

Lisa Wissbaum (University of Minnesota) – Administrative Director

Site Visit Team

Sumanta Acharya (National Science Foundation)

Lesia Crumpton-Young (Powerful Education Technologies, LLC)

Larry Fehrenbacher (Technology Assessment and Transfer, Inc.)

Saeid Habibi (McMaster University)

Bruce Kramer (National Science Foundation)

Andrew Moskalik (US Environmental Protection Agency)

Lynn Preston (National Science Foundation)

Erik Sander (University of Florida)

Paul Sheldon (Sheldon Works)

Andras Szeri (University of Delaware)

Kenneth Waldron (Stanford University)

Education and Outreach

Another mission of the CCEFP is educational outreach programs that promote the teaching of science and technology concepts related to fluid power. The outreach occurs at both the secondary and graduate levels and encourages participation from underrepresented minorities.

REU Bootcamp at Maha

One of these outreach programs, the 2013 CCEFP Fluid Power REU Bootcamp, was held at Purdue University on May 29-30, 2013. Around 20 undergraduate students from various U.S. universities joined the Center's universities (Georgia Tech, University of Illinois in Urbana-Champaign, University of Minnesota, Milwaukee School of Engineering, North Carolina A&T State University, Purdue University, and Vanderbilt University) to perform research in fluid power during the summer period.

A crash course was designed to teach the students the fundamental principles of hydraulics and pneumatics. The program started by an opening address by Prof. Monika Ivantysynova about fluid power in general and then a lecture entitled "Introduction to Fluid Power Systems" by Prof. Andrea Vacca. The students attended the following lectures / demonstrations:

- "Hydraulic Components Characterization on the Water Hydraulic Test Rig" prepared by Guido Francesco Ritelli

- "Parker Trainer Bench: Motion Control" prepared by Gabriele Altare

- "Pump Displacement Controlled Actuation Technology" prepared by Naseem Daher

The bootcamp was also a great networking opportunity for the participants to meet other students and faculty members in the Center.



ASME/BATH 2013 Symposium on Fluid Power and Motion Control (FPMC)



The 2013 annual ASME/Bath Symposium on Fluid Power and Motion Control, in which Monika Ivantysynova was responsible for the organization of as a general co-chair of the conference, was held at the Lido Beach Resort in Sarasota, Florida on October 6-9. The conference was jointly organized by the University of Bath and the American Society of Mechanical Engineers (ASME) and has been held every year alternating between Bath and locations in the USA since 2009. In the past, this conference has been paired with the ASME Dynamic Systems and Control Conference. This year the conference was for the first time organized by the ASME Fluid Power Division. This conference was sponsored by, in total, 10 major fluid power companies, Fluid Power Net International, and the National Fluid Power Association. Also this year, it was very exciting to partner with the NSF Center for Compact and Efficient Fluid Power (CCEFP) who had scheduled their annual conference in Sarasota to follow this event. Together, these conferences strive to provide a means to get the international fluid power community from academia and industry together to discuss recent developments and future challenges in fluid power technology.

This year, a record number of 99 paper submissions were received, with a final program including 60 papers. Following the long tradition of the Bath Symposium of avoiding parallel sessions, the 60 papers were presented in 12 sessions evenly distributed with two morning sessions and two evening sessions over the three days of the conference. These 12 sessions were divided as follows: Actuation and Control 1, Tribology and Lubrication, Valves, Energy Applications and Energy Storage, Actuation and Control 2, System Health Monitoring and Fault detection, Digital Hydraulics and Digital Displacement, Efficiency, Pumps and Motors, Properties of Hydraulic Fluids, Modeling and Design, and Actuation and Control 3. This program also included social events on each day of the conference. These events started with an opening reception on Sunday at the resort and ended with a joint reception with the CCEFP annual meeting on Wednesday which also

included a poster presentation. On Monday evening, Sun Hydraulics hosted a tour of their facilities that was followed by a dinner barbecue. Tuesday evening featured the Koski Banquet which included the Koski Lecture presented by Wayne Book, the 2013 Koski medal awardee in which he received “for a lifetime of contributions and leadership in fluid power education and research related to motion control and the impact of operator interfaces on the control of hydraulic manipulation systems.”

The conference was a great success and a technically rewarding event to everyone involved.

Sunday Opening Reception



Sun Hydraulics Facility Tour



Barbecue



Koski Banquet



Joint Reception FPMC2013/CCEFP



Lido Beach Sarasota, FL



Organizers

General Co-Chairs

Monika Ivantysynova (Purdue University, USA)

Kim Stelson (University of Minnesota, USA)

Local Arrangement, Registration, and Finance Chair

Steve Weber (Sun Hydraulics Corporation, USA)

Program and Publicity

Roger Fales (University of Missouri, USA)

Saeid Habibi (McMaster University, Canada)

Nigel Johnston (University of Bath, UK)

Editorial and Publication

Eric Barth (Vanderbilt University, USA)

Andrea Vacca (Purdue University, USA)

Editorial Board Members

Eric Bideaux (Institut National des Sciences Appliquees de Lyon, France)

Will Durfee (University of Minnesota, USA)

Bernhard Manhartsgruber (Johannes Kepler University, Austria)

Massimo Milani (University of Modena and Reggio Emilia, Italy)

Roberto Paoluzzi (IMAMOTER – C.N.R., National Research Council of Italy, Italy)

Robert Rahmfeld (Sauer-Danfoss, Germany)

Kazushi Sanada (Yokohama National University, Japan)

Kazuhiro Tanaka (Kyushu Institute of Technology, Japan)

9 Maha in the News

Research at the Maha Fluid Power Research Center has generated some public interest this year. A selection of these articles is included after the following list of references:

- Daher, Naseem. “New approach to steering off-road vehicles”, STLE | TLT magazine, January 2014.
<http://digital.ipcprintservices.com/publication/?i=188982>
- Daher, Naseem. “New Hydraulic Technology for Efficient Machine Steering”, ASABE Resource Magazine, January/February 2014.
<http://bt.e-ditionsbyfry.com/publication/?i=190183>
- “Valveless Hydraulics Cuts Fuel Consumption in Construction Vehicles”, Design News Blog, October 24, 2013.
http://www.designnews.com/author.asp?section_id=1386&doc_id=269044
- “Fuel-Efficiency in the Construction Industry”, MyCarma Blog, November 29, 2013.
<http://blog.mycarma.com/2013/11/29/fuel-efficiency-in-the-construction-industry/>
- “New steering tech for heavy equipment saves fuel, ups efficiency”, Purdue News, September 23, 2013.
<http://www.purdue.edu/newsroom/releases/2013/Q3/new-steering-tech-for-heavy-equipment-saves-fuel,-ups-efficiency.html>

New approach to steering off-road vehicles

A more efficient steering system has been developed that improves productivity and reduces fuel consumption.

THE MOVEMENT TO IMPROVE THE EFFICIENCY OF MOBILE VEHICLES also includes off-road equipment. Hydraulic fluids, which have been treated just as commodity lubricants, are taking on more importance in helping to increase the efficiency of off-road equipment.

In a previous TLT article, viscosity index (VI) improvers were identified as helping to improve the performance of off-road equipment by enabling

'In multi-actuator machines, the new pump-controlled actuation technology requires each actuator to have its own pump, thus eliminating the need for valves.'

KEY CONCEPTS

- Off-highway machines using standard hydraulic steering technology are inefficient because 25 to 30 percent of the hydraulic power is lost as heat.
- Pump-controlled steering has been developed and involves the use of a variable displacement pump dedicated for each steering actuator.
- Compared to standard hydraulic steering, pump-controlled steering in a front loader achieved a fuel savings of nearly 15 percent and a productivity improvement of nearly 23 percent.

end-users to find the right viscosity window, which maximizes fuel economy and productivity while minimizing emissions.¹ The idea is to have a hydraulic fluid operate in an optimum viscosity range to minimize excessive leakage that can occur at too low a viscosity and also minimize pump starvation that can occur if the viscosity is too high.

Research is continuing to determine how to improve the hydraulic systems used in off-road equipment. The development of displacement-controlled actuators is described in a previous TLT article.² Use of displacement-controlled actuators led to an energy savings of 39 percent in a commercially available excavator that had been using load-sensing hydraulic systems.

Another system where improved efficiency is needed is steering. Monika Ivantysynova, Maha Fluid Power Systems Professor in the department of mechanical engineering at Purdue University in West Lafayette, Ind., says, "Currently, steering of off-highway machines is done using standard hydraulic steering technology which involves the use of a central displacement pump that delivers hydraulic

fluid through a series of valves to different actuators."

Ivantysynova explains that the off-highway equipment operator initiates steering through mechanical input by turning a wheel. This step is amplified by the standard hydraulic steering system.

The problem with standard hydraulic steering is the multiple valves set up between the displacement pump and the steering actuator. These valves control fluid power, not just for steering but for other working hydraulic functions. Upstream of the steering valve is a priority-steering valve that ensures fluid is available for steering and may restrict fluid flow for other functions.

Ivantysynova says, "The multiple restrictions from these valves limits fluid flow by throttling and hinders the power available to the off-highway equipment. The result is that much of the power is converted to heat, which is lost to the environment."

Ivantysynova estimates that as much as 25 to 30 percent of the hydraulic power is lost as heat. A need exists for a more efficient steering system that will improve productivity and

'We believe that fuel savings of at least 20 percent can be found with the pump-controlled steering system. Another benefit is that using the system leads to less operator fatigue because there is less difficulty in turning the wheel.'

reduce fuel consumption. Such a system has now been developed.

PUMP-CONTROLLED STEERING

Ivantysynova, in collaboration with her co-researcher, Naseem Daher, has developed a new approach known as pump-controlled steering that relies on a variable displacement pump dedicated for the steering actuator. She says, "In multi-actuator machines, the new pump-controlled actuation technology requires each actuator to have its own pump, thus eliminating the need for valves. This enables the pressure flow from the pump to be optimized for each actuator."

For off-highway equipment, the question may be asked about whether there is sufficient room for multiple pumps and whether the weight of the vehicle may actually rise, which would lead to lower fuel economy. Ivantysynova answers, "This is not the case with pump-controlled steering. As an example, if a 200-kilowatt pump used in a specific application is replaced with four pumps that each generate 50 kilowatts, less space is required for the multiple pumps and the equipment containing the multiple pumps weighs less."

The result of pump-controlled steering is a significant increase in productivity combined with a significant reduction in the amount of energy lost as heat. Ivantysynova says, "In our approach, energy is not wasted as heat but, rather, used to provide much better control over each actuator."



Figure 1 | Testing in the front loader shown indicates that a new technology known as pump-controlled steering exhibits superior fuel savings and productivity compared to standard hydraulic steering. (Courtesy of Purdue University)

The researchers installed the pump-controlled steering system in a front loader shown in Figure 1. A servo-pump and a torque feedback device were installed into the front loader, which control articulation velocity and steering wheel torque, respectively. Under identical operating conditions to what was done with the standard hydraulic steering system, a fuel savings of nearly 15 percent and an improvement in productivity of nearly 23 percent were achieved. This leads to a total fuel efficiency increase of nearly 43 percent for the front loader.

Ivantysynova says, "We believe that fuel savings of at least 20 percent can be found with the pump-controlled steering system. Another benefit is that using the system leads to less operator fatigue because there is less difficulty in turning the wheel. Safety is also enhanced with our new steering system via active safety functions."

The operator does not face the same amount of torque when turning the steering wheel with the new system. Though this may lead to a problem because of the lack of tactile feedback, safeguards have been put in place to regulate torque feedback.

Retrofitting off-highway equipment to the pump steering system is not difficult, according to Ivantysynova. The same hydraulic fluid used in the current steering system can be used in the new system.

The researchers are in the process of looking for partners to run additional testing on off-highway equipment to validate pump-controlled steering. Additional information can be found in a presentation given at a recent conference¹ or by contacting Ivantysynova at mivantys@purdue.edu.

REFERENCES

1. Canter, N. (2011), "Viscosity Index Improves," *T.L.I.*, 67 (9), pp. 10-22.
2. Canter, N. (2008), "Improving Efficiency of Mobile Hydraulic Systems," *T.L.I.*, 64 (10), pp. 14-15.
3. Ivantysynova, M. and Daher, N. (2013), "Pump Controlled Steer-by-wire System," Presented at the SAE 2013 Commercial Vehicle Engineering Congress, Oct. 1-3, Rosemont, Ill.



© Porfumo316 | Dreamstime.com

New Hydraulic Technology for Efficient Machine Steering

Naseem Daher and Monika Ivantysynova

Fossil fuel prices are not going back down to their early 2000s levels, period. This fact, along with increased environmental awareness to decrease hydrocarbon emissions, has pressed researchers in all disciplines to increase the energy efficiency of machines and reduce their carbon footprint. This article describes an energy-efficient steering technology that has been implemented on a wheel loader. This new steering system decreased fuel consumption by 15%, increased machine productivity by 23%, and boosted overall fuel efficiency by a whopping 43%. These results are aligned with the goals of the mobile machinery industry, in which reducing fuel consumption and increasing machine productivity are of utmost importance to both original equipment manufacturers (OEMs) and their end customers. The industry has been longing for a breakthrough technology that meets these pressing challenges.

State-of-the-art technologies that power the working hydraulic functions of mobile machines mainly use hydraulic actuation, load-sensing in particular, for motion control. Load-sensing systems are more efficient than their predecessors, but they still result in considerable energy dissipation due to throttling losses across their control valves.

A revolutionary technology that has proven to be an energy-efficient alternative to valve control is now available. This technology, known as pump displacement controlled (DC) actuation, improves energy efficiency by doing away with control valves for high-power motion control and uses instead a variable-displacement pump to regulate the hydraulic flow rate. In the past decade, DC technology has been researched and implemented for the working hydraulic functions of several mobile machines. DC resulted in 15% fuel savings on a wheel loader, 20% fuel savings on a skid-steer loader, and 40% fuel savings on an excavator. These

are such significant results that they cannot go unnoticed any longer. However, for DC actuation to become mainstream, it must be capable of realizing all of the hydraulic functions used on mobile machines.

One of the systems that has not been explored for the implementation of DC technology is the steering system. A DC steering system can be classified as an electro-hydraulic steer-by-wire system. *X*-by-wire systems, where the *X* stands for fly, drive, brake, or steer, are the control systems of the future. This trend started in the aerospace industry, transitioned into the automotive sector, and has been finding its way into earth-moving machines. As such, the steering system described in this article is in harmony with the long-term vision of OEMs, but it is readily available and could be implemented in the near future. By now, you're probably starting to wonder how the new system works.

How does the new DC steer-by-wire system work?

Figure 1 is a schematic of the new DC steer-by-wire system. The actuator (8) velocity is controlled by adjusting the speed, displacement, or both, of an axial-piston variable-displacement pump (2). The pump input and output ports are connected to the piston and rod sides of the actuator. The differential fluid flow between the actuator's uneven sides is

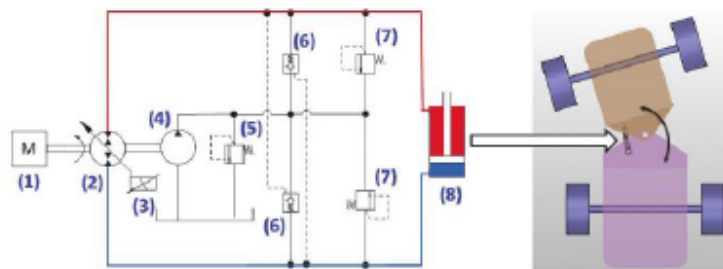

Figure 1. DC steer-by-wire hydraulic schematic.

overcome by means of pilot-operated check valves (6), which keep the low-pressure side of the actuator connected to a low-pressure source that can either provide or absorb flow to prevent evacuation. The low-pressure source has its own fixed displacement charge pump (4) that provides continuous flow to the cylinder's low-pressure side. The low-pressure level setting is adjusted by a pressure-relief valve (5). The system is protected from overpressurization by pressure-relief valves (7) installed on both sides of the actuator. The pump displacement control system (3) uses an electrohydraulic proportional control valve to adjust the swash plate angle of the pump.

Like any X-by-wire system, the DC steering system eliminates the physical connection between the steering wheel and the steering components. Hence, the steering wheel feedback would be lost without the incorporation of a tactile feedback device. Using electronic control, the DC steering system can reduce operator fatigue at low speeds while improving safety at high speed by controlling the level of steering wheel torque that is fed back to the operator. This feedback is regulated based on the steering wheel angle and turning speed, the vehicle speed, and the articulation angle between the two frames. Thus, the system can simulate end-of-rotation stops, limit the steering wheel's rotation speed, and provide variable effort as a function of vehicle speed. Control of the pump displacement (flow rate) and steering wheel torque is executed by an electronic control unit, which receives the sensor signals and commands the pump adjustment system and the torque feedback device to produce the desired performance. Figure 2 shows these electronic signals.

Advantages of the New Technology

The new technology offers improved fuel efficiency, flexibility of steering feel and sensitivity gains at various operating conditions, active safety features (e.g., stability control), improved line holding capability, potential for autonomous machine operation, and more. In addition to eliminating the hydraulic control valves, the system architecture and control

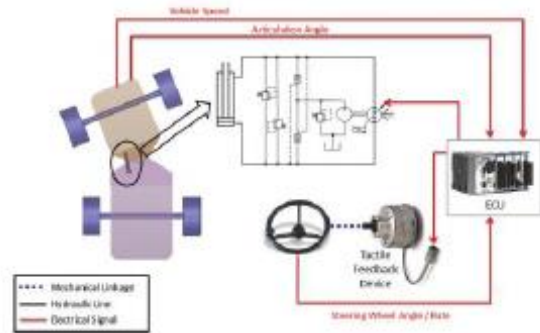
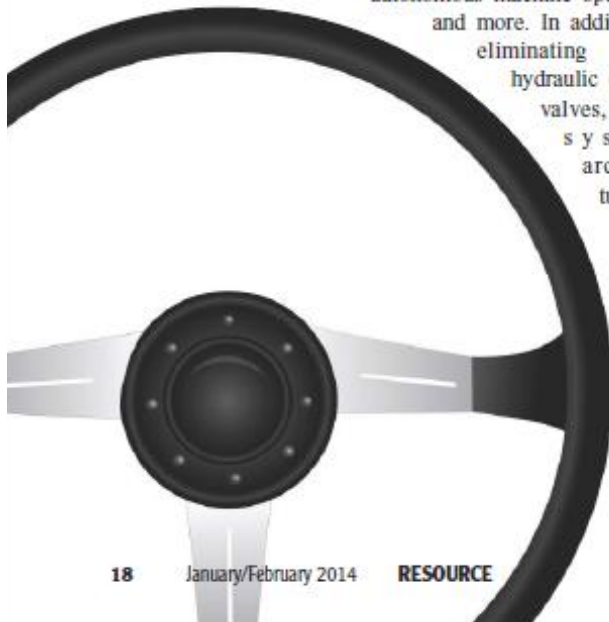

Figure 2. DC steer-by-wire system control.

schemes are simplified with the new technology. Reducing the required cooling power is also possible due to lower heat generation at the fluid level. In some applications, there is a possibility of reducing the engine power, since the new technology lends itself to hybridization by capturing available kinetic and potential energy and storing it for later use.

Implementation of the New Technology

The new system was retrofitted on a compact (five ton) wheel loader at Purdue University's Maha Fluid Power Research Center. Prior to the hardware implementation, comprehensive analysis was performed to properly size the new system and components, develop a high-fidelity dynamic model of the hydraulics and vehicle dynamics, and design appropriate control algorithms that result in optimal steering performance. The stock machine with its load-sensing hydrostatic steering system was tested to establish a benchmark for later evaluation of the new DC steering system. Once the analytical phase and baseline testing were concluded, the stock steering system components were removed and the new DC steering system components were installed, along with the required sensors, signal conditioning modules, data acquisition system, and real-time controller. The two main compo-



Figure 3. DC steering system hydraulic components: the steering pump is enclosed in the red dashed rectangle, the proportional control valve is enclosed in the green dashed rectangle, and the charge pump is enclosed in the blue dashed rectangle.

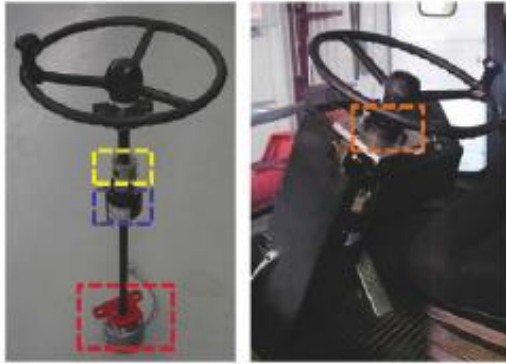
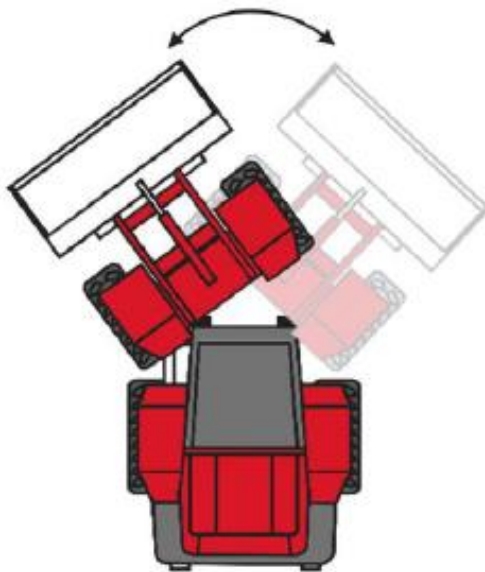

Figure 4. New DC steer-by-wire system steering column assembly: the torque feedback device is enclosed in the red dashed rectangle, the steering wheel torque sensor is enclosed in the yellow dashed rectangle, a slip ring for managing the torque sensor cable is enclosed in the blue dashed rectangle, and the steering wheel angle sensor is enclosed in the orange dashed rectangle.

nents of the new system include the hydraulic components and the steering column assembly. The hydraulic components are shown in figure 3, and the mechanical components of the steering column are shown in figure 4.

Validation of the New Technology

A steering-only maneuver was devised such that only the steering system was active during the cycle. During the test, the machine was fully articulated from left to right while staying



Steering-only test maneuver.

Test results for stock hydrostatic steering and new DC steering.

	Fuel Consumption (kg)	Total Steering Work Done by Machine (MJ)	Steering Work per Fuel Mass (MJ kg ⁻¹)
Stock steering system	0.291	0.639	2.232
New DC steering system	0.249	0.784	3.203
Difference	-14.5%	+22.6%	+43.5%

stationary in the longitudinal direction; hence, the transmission remained in neutral. The boom and bucket functions were maintained at predetermined settings, requiring no hydraulic power supply. The axle loads were established with a fixed bucket load and specified surfaces. The engine throttle was held at its maximum level, and the cycle duration was fixed. The above table summarizes the results attained after performing the steering-only maneuver with the stock hydrostatic steering system and with the DC steer-by-wire system.



Prototype test vehicle with DC steer-by-wire system.

The DC steer-by-wire system delivers considerable fuel savings, increased machine productivity, and improved overall fuel usage efficiency. The new steering system also yields excellent controllability and non-synthetic steering wheel feel that meets or exceeds the conventional feel. Future research will look into using virtual sensors for active safety functions such as stability control, investigate adaptive control algorithms to make the machine adapt to varying operating conditions and uncertain parameters, and bring the technology closer to tele-operation and potentially fully autonomous operation.

The DC steer-by-wire system delivers considerable fuel savings, increased machine productivity, and improved overall fuel usage efficiency. The new steering system also yields excellent controllability and non-synthetic steering wheel feel that meets or exceeds the conventional feel. Future research will look into using virtual sensors for active safety functions such as stability control, investigate adaptive control algorithms to make the machine adapt to varying operating conditions and uncertain parameters, and bring the technology closer to tele-operation and potentially fully autonomous operation.

Naseem Daher, Ingersoll-Rand Fellow and Doctoral Student, School of Mechanical Engineering, Purdue University, West Lafayette, Ind., USA, ndaher@purdue.edu.

Monika Ivantysynova, Maha Professor of Fluid Power Systems, Director of the Maha Fluid Power Research Center, School of Mechanical Engineering and Department of Agricultural and Biological Engineering, Purdue University, West Lafayette, Ind., USA, mivantys@purdue.edu.

Maha CCEFP Research Highlights

CCEFP Industry Members Utilize Advanced Pump Models

CCEFP researchers have achieved major breakthroughs in developing a better understanding of the fundamental physical behavior in critical tribological pump and motor interfaces. Recently researchers successfully extended the non-isothermal fluid structure interaction model previously developed for the piston/cylinder interface to the other two important interfaces of piston machines. The novel fully coupled fluid structure interaction model allows predicting fluid film behavior in all main pump interfaces. This information is crucial for the design of positive displacement machines, because the correct working process, the main achievable operating parameters, the energy dissipation and power loss are directly linked to the fluid film behavior. Recent discoveries together with the developed multi-physics model form the starting point for a new computational based design approach. These achievements have created major interest of pump and motor manufactures. CCEFP research results have been used to develop custom made code to study and optimize current pumps and motors of CCEFP member companies and to utilize digital prototyping methods in future pump design.

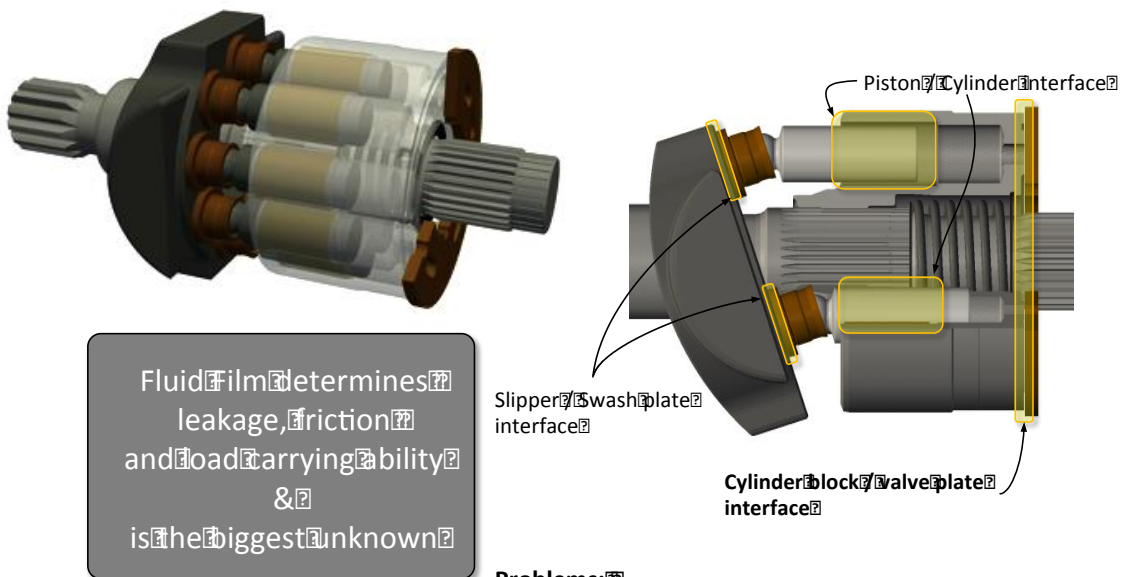

Problems:

- Energy dissipation due to viscous friction and oil leakages. **Main source of power losses.**
- Wear and failures

Powertrain Research Additions to Purdue's Maha Lab

Research of Purdue's Maha team centers on investigating the feasibility and performance of alternative drive line technologies for different types of vehicles. The aim is to develop system concepts for minimizing fuel consumption and exhaust emissions without limiting the vehicle's driving power. A special software tool called PSDD (Power Split Drive Design) has been developed to support virtual prototyping of power split drives, multi-motor hydrostatic transmissions and hydraulic hybrid power train configurations. The research activities are supported by performance measurements using pump and motor test rigs and two hardware-in-the-loop power train test rigs. A 180 kW power train test rig uses hydrostatic dynamometers. A second powertrain test rig utilizing electric dynamometers has been built recently to enlarge the testing capacity of the Maha lab. In a recent study Maha researchers demonstrated that the optimally sized and controlled hydraulic hybrid powertrain for the Prius is able to obtain a fuel economy of 65.1 mpg, up from the EPA's published value of 48 mpg for the 2004 electric Prius on which the study was based. The power split based hydraulic hybrid system for the Prius has been implemented and tested on one of the Maha powertrain test rigs. The other power train test rig is currently used to study and proof advanced powertrain control concepts and the behavior of novel energy efficient fluids under realistic drive cycles.

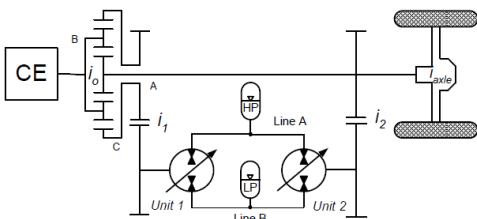
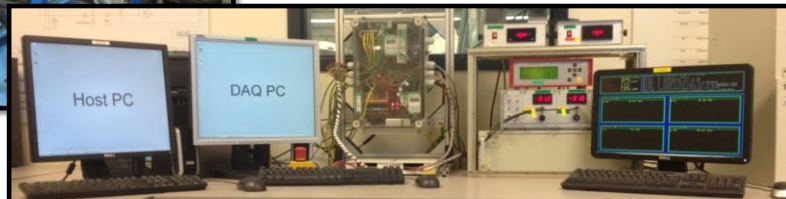
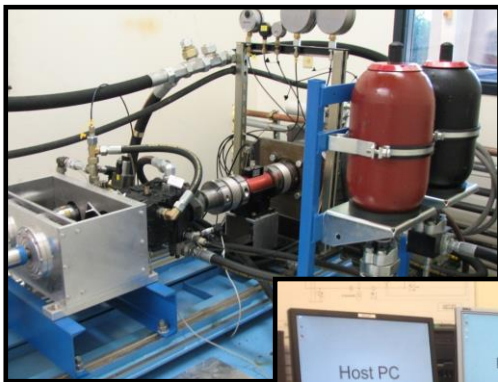

World's First Energy-Efficient Hydraulic Hybrid Excavator

CCEFP researchers built the first hydraulic hybrid excavator based on the patent filed by Ivantysynova and Zimmerman in 2011. The novel hydraulic hybrid system combines hydraulic hybrid technology with energy efficient displacement controlled actuation. Hydraulic accumulators are used to store and reuse brake energy, which helps to further reduce fuel consumption. Novel control and power management concepts allow effective power flows between actuators, engine and accumulator. System simulations have shown, that the combination of both novel technologies in one system architecture allows 50% engine downsizing and up to 20% additional fuel savings over the non-hybrid displacement controlled excavator. In 2010 measurements made by Caterpillar on the CCEFP developed non-hybrid displacement controlled excavator had demonstrated 40% fuel savings and 69% machine efficiency improvements in ton soil moved per kg fuel burned. The hybrid system has been implemented in the CCEFP excavator test bed, the 5-t displacement controlled mini-excavator. The machine is operational and ready for first machine performance measurements, which are planned for spring 2013.

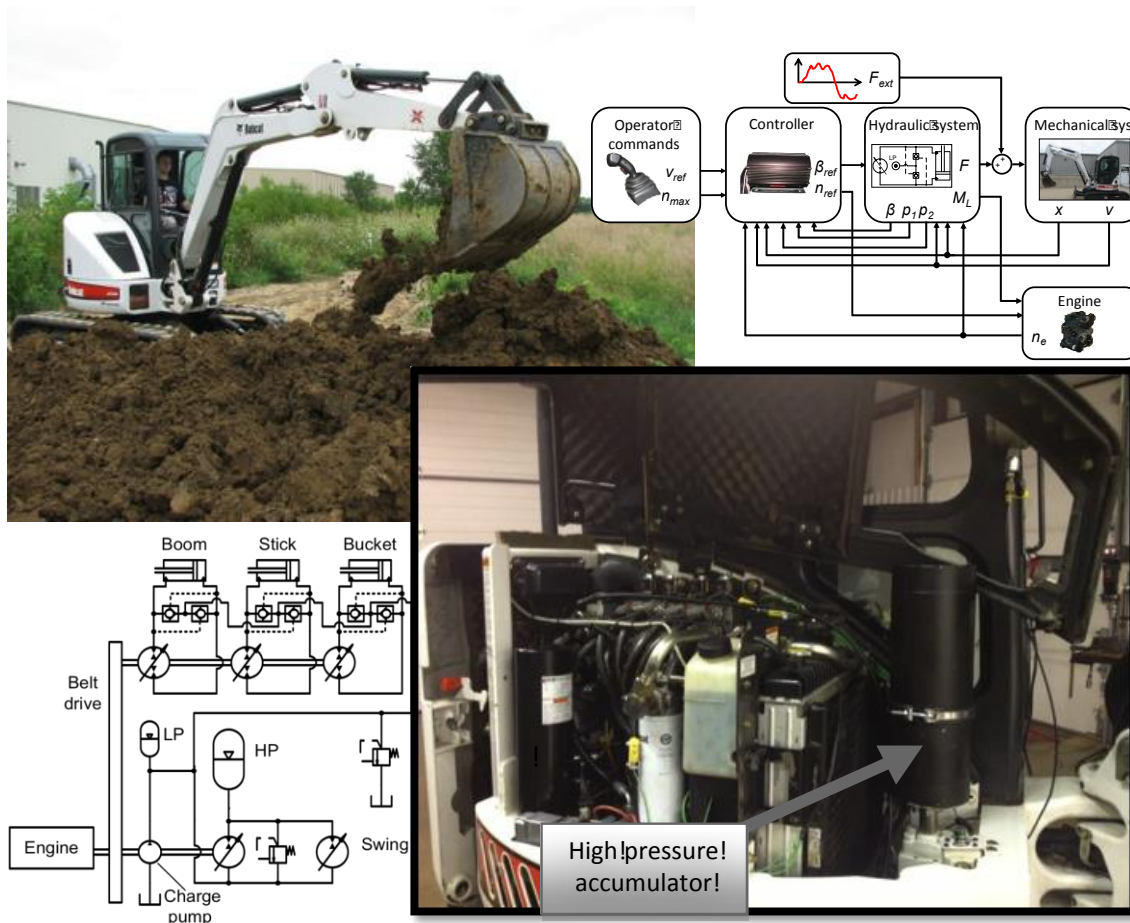

Pump Research Discloses the Secret of the Fluid Film

Pump and motors form the heart of each fluid power system. Thin fluid films separate highly loaded movable pump and motor surfaces from each other and prevent wear and fatal machine failures. Despite many decades of worldwide intensive research experts and pump designers still lack a complete understanding of the complex physical behavior of these thin critical fluid films.

CCEFP researchers have combined experimental research with advanced multi-domain modeling to discover the secrets of the fluid film in those important pump and motor interfaces. A major breakthrough was the discovery of the fundamental importance of elasto-hydrodynamic and thermal effects on film generation and film stability. Recent research results have proven that these phenomena are responsible for substantial modification of the fluid film thickness and need to be considered in addition to micro and macro motion effects to correctly predict fluid film behavior. Researchers discovered that thermal expansion due to energy dissipation in the fluid film could introduce a wavy surface shape that helps to improve the load carrying ability of the fluid film. The inclusion of these additional effects however, increases enormously the complexity of the simulation model and has required tailoring numerical techniques and the modeling approach to the specific needs of each interface. The researchers created the world's first fully-coupled fluid-structure interaction and multi-body dynamics simulation model that also considers thermal deformation of main interfaces and their influence on fluid film behavior. The model will be used to investigate the potential of novel material combinations and specially shaped surfaces to increase load carrying ability of the film while simultaneously reducing energy dissipation.

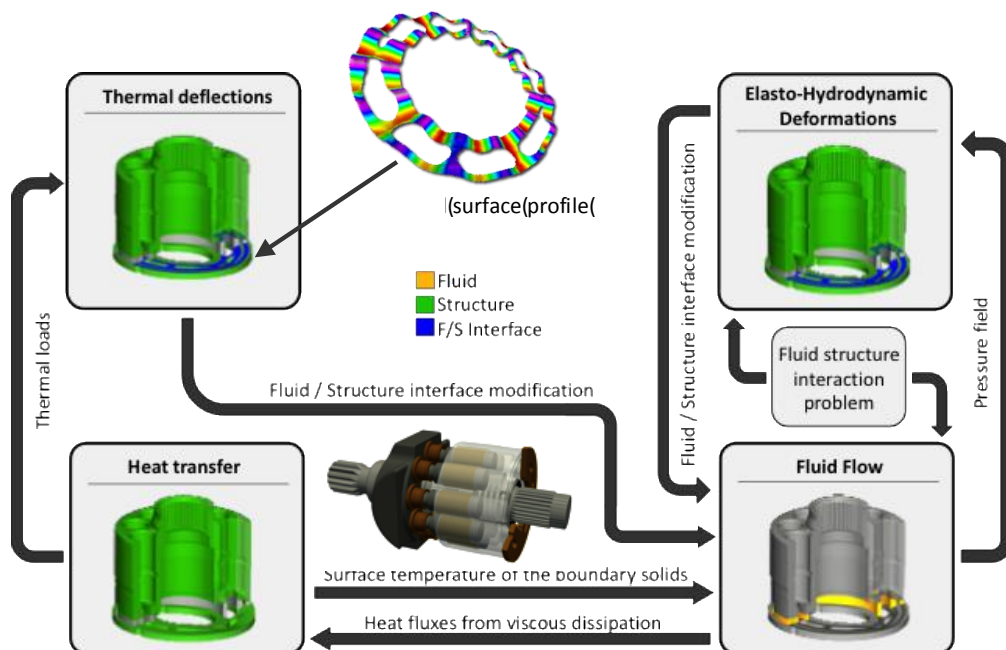

10 Awards, Honors, and Recognitions

2013 SAE Excellence in Oral Presentation Award.

Daher, N. and Ivantysynova, M. 2013. Pump Controlled Steer-by-Wire System. SAE 2013 Commercial Vehicle Engineering Congress, , Oct. 1-3 2013, Rosemont, IL, USA. SAE Technical Paper 2013-01-2349.



Center for Compact and Efficient Fluid Power (CCEFP) annual meeting Best Poster Awards

Ashley Wondergem and Rohit Hippalgaonkar received Honorable Mentions for their posters presented during the Center for Compact and Efficient Fluid Power (CCEFP) annual meeting that was held in Sarasota, Florida on Oct. 9-11, 2013

SAE Fellow grade for Prof. Monika Ivantysynova has been elected to SAE Fellow grade of membership, which is SAE's premier membership grade, intended to "honor and recognize important engineering, scientific, and leadership achievements to enhance the status of SAE's contributions to the profession and to society."

The SAE Fellows Committee selected Prof. Ivantysynova for her outstanding achievements in fluid power research, developing energy efficient systems for mobile vehicle applications. Prof. Ivantysynova will be honored during the SAE 2014 World Congress and Exhibition in Detroit, Michigan, U.S.A. the week of April 6, 2014.

2013 SURF “Graduate Student Mentor of the Summer” award for Andrew Schenk

Maha SURF student, Jordyn Miller, nominated Andrew for this honor by sharing her experiences and rating Andrew based on “technical and instructional competence, supervision/guidance, passion/enthusiasm for research, and motivation.”

Maha's DC Excavator Nominated by NSF for the 2013 Popular Mechanics Breakthrough Award!

This recognition is for “innovators or teams of innovators who are making important advances in the fields of engineering, technology, medicine, and other applied sciences with a potential for large social impact.” The DC mini excavator with its new hydraulic hybrid architecture for the swing drive represents the world’s first prototype of its kind.

Ingersoll-Rand Fellowship for Naseem Daher

The fellowship is awarded to PhD students with outstanding academic record, who are nominated by their major professor based on research progress, performance, publications and presentation.

11 Educational Activities

Courses Taught at Purdue

Dr. Ivantysynova has taught, developed or been advisor to several courses in her time thus far at Purdue:

- ABE 691 / ME 697 – Hydraulic Power Trains and Hybrid Systems (*Spring 2008, 2009, 2010, and 2012*)
- ME 597/ABE 591 – Design and Modeling of Fluid Power Systems (*Fall 2005, 2006, 2007, 2008, 2009, 2010, 2011, and 2012*)
- ME 463 – Senior Design Project (*Spring 2006, 2007, 2008, 2009, and 2011*)
- ABE 697 – Seminar (*Fall 2009*)

ME 597 /ABE 591 – Design and Modeling of Fluid Power Systems

Fall Semester 2013

2013 marked the ninth consecutive year of ME 597/ABE 591 being offered.

Course Description:

ME 597/ABE 591 Design and Modeling of Fluid Power Systems

1 Semester, 3 Lecture/week, 3 Credits

Prerequisite: ABE 435 or ME 309, ME 375 or consent of instructor.

This course provides an introduction into modeling and design of fluid power components and systems. Modeling techniques based on physical laws and measured performance characteristics will be applied to design and analyze component and system performance. Fundamentals: design principles of displacement machines, flow and pressure control, motion control using resistance control, motion control using displacement controlled actuators, variable speed transmissions, modeling of flow in lubricating gaps, transmission line models, secondary controlled systems, load sensing systems.

Textbook:

Course Notes

References:

J. Ivantysyn and M. Ivantysynova: Hydrostatic Pumps and Motors Principles, Design, Performance, Modelling, Analysis, Control and Testing. Akademia Books International, New Dehli, 2001.

Fitch, E.C. and I.T. Hong: Hydraulic Component Design and Selection. BarDyne, Inc. 1998.

H. E. Merritt. Hydraulic Control Systems. John Wiley & Sons, Inc.

Coordinator:

M. Ivantysynova, Maha Professor of Fluid Power Systems, ME and ABE

Goals:

To give seniors and graduates students in engineering the ability to design and analyze fluid power systems applying computational methods. The course is designed to teach students how to apply engineering fundamentals to develop mathematical models of fluid power components and systems, so that advanced systems can be developed.

Prerequisites by Topic:

Fluid Mechanics

Modeling and analysis of physical systems

Differential equations and calculus

Topics:

1. Introduction and overview of components, circuit and system design methods
2. Fluid properties, modeling of transmission lines, impedance model of lines
3. Displacement machines design principles
4. Steady state characteristics, measurement methods and modeling
5. Gap flow models
6. Flow and pressure pulsation
7. Resistance control, modeling of steady state and dynamic performance
8. Pressure and flow control valves
9. Servo and proportional valves, nonlinear and linear system models
10. Modeling of valve controlled systems, linear and rotary actuators
11. Modeling of displacement controlled actuators, pump control systems
12. Secondary controlled actuator, modeling and application
13. Special system design aspects, load sensing systems

Computer Usage:

Required in solution of homework problems and final design project. Matlab experience would be helpful but not necessary.

Laboratory Project:

Hardware-in-the-loop test rig of a vehicle drive line

Aim:

To learn to plan, design and operate an experimental test set up for performance testing of a fluid power system. To become familiar with X-PC target software, measurement equipment and data acquisition system used on a hardware in-the-loop test rig of a vehicle drive line. The project should also prove the student's ability to perform a measurement, evaluate test data and write a measurement report in an appropriate form.

Method:

Students will have to form teams of three students. One lecture will be used for introduction into the problem and the existing test rig. Students will then have to learn to operate the test rig and to perform measurement. Each team has to write a measurement report.

Formulation of Problem:

Students are requested to perform the following work:

1. Study the test rig structure including the X-PC target system and describe it in the report accordingly.
2. Specify a drive cycle of the vehicle you like to test using the hardware-in-the loop test environment.
3. Perform the measurement of the drive cycle.
4. Evaluate the test results and complete a report.

Nature of the Design Content:

The design component of this course will consist of students designing a fluid power system to meet a particular need and required performance. The students will solve several sub problems of an entire system design as part of the regular course homework.

Engineering Project to be Completed During the Course

Aim:

To demonstrate in form of an engineering project the ability to design fluid power systems, to understand the function of components and how to model their steady state and dynamic behavior to predict the system performance. The project should also prove the student's ability to write an engineering report in an appropriate form.

Method:

Students will solve several sub problems of the entire system design work as part of the regular course homework.

Formulation of Problem:

Students are requested to perform the following work:

1. Choose and define your own system design project, i.e. define a hydraulic actuator, drive system or transmission as a part of a machine or vehicle. Describe briefly the machine or vehicle function.
2. Specify the system requirements (work task, operating parameter range, safety issue, energy consumption, type of primary energy source) and conclude the requirements in form of a system specification as the first chapter of your project report.
3. Remember to apply individual course topics to your system
4. During the semester it will be requested that you add a second actuation system to your initial one. This is to ensure that each project has at a minimum one rotary and one linear drive system.
5. It is also necessary that you investigate and compare at least one alternative solution for one of your chosen actuator/drive or transmission solution. The comparison must include energy consumption and a brief statement of other properties (system complexity, costs etc).
6. Define system structure, draw circuit diagram and a scheme showing the interfaces between your fluid power system and the entire machine/vehicle.
7. Select type and size of components
8. Create models to describe the loss behavior, energy consumption
9. Create models to predict system behavior including dynamics (system parameter as function of time)
10. Define measurement methods and test procedure for a selected component and your whole actuation system
11. Write the system development report

ABET category content as estimated by faculty member who prepared the course description:

Engineering Science: 1.5 credits or 50%

Engineering Design: 1.5 credits or 50 %

Grading: 60% engineering project, 30 % written final exam, 10 % measurement report



Design and Modeling of Fluid Power Systems ME 597 / ABE 591

Fall Semester 2011

This course provides an introduction into modeling and design of fluid power components and systems. Modeling techniques based on physical laws and measured performance characteristics will be applied to design and analyze component and system performance. Fundamentals: design principles of displacement machines, flow and pressure control, motion control using resistance control, motion control using displacement controlled actuators, variable speed transmissions, modeling of flow in lubricating gaps, transmission line models, secondary controlled systems, load sensing systems.







▪ **Valve controlled systems**

To learn how to model fluid power components and systems based on physical laws and when to use these models.

- Modeling and design of linear actuators
- Dynamic performance
- Design example

▪ **Displacement Machines**

- Design principles
- Steady state characteristics, measurement and modeling
- Gap flow models
- Flow and pressure pulsation
- Instantaneous cylinder pressure





▪ **Displacement controlled systems**

To learn how to design advanced energy saving hydraulic actuators and transmissions and to predict their performance.

- Pump control system design
- Design of hydrostatic transmissions
- Secondary controlled actuators
- Pump controlled linear actuator

▪ **System design - special topics**

- Power supply systems
- Load sensing
- Energy aspects

▪ **Resistance Control**

To learn to design fluid power systems and to understand the function of components and how to model their steady state and dynamic behavior. To determine steady state and dynamic characteristics of fluid power components and systems based on measurements

- Pressure and flow control
- Servo- and proportional valves
- Nonlinear and linear system models



by Monika Ivantysynova, MAHA Professor Fluid Power Systems

- **Tuesday 8:00 - 11:00 @ MAHA LAB, 1600 Kepner Drive, Lafayette**
- **Thursday 1:00 – 2:45 (lab 2 times only)**
- **3 credits**

12 Maha Social Events

Life in the Maha lab is not always about work. Occasionally we are able to get together and enjoy each other's company. Below are some highlights of the past year.

Annual Dinner Party at Monika's House





Celebrating Marco's Successful PhD Defense



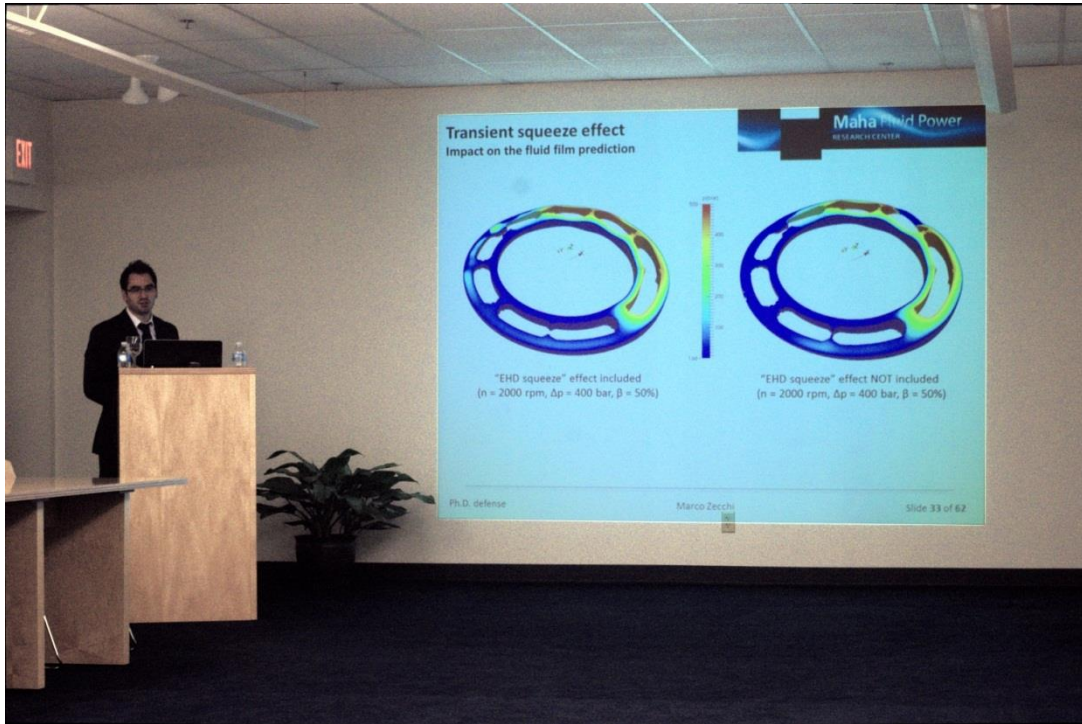

Celebrating Davide's Successful PhD Defense





Summer Party at Susan's House





Mizell Baby Shower





Morning Coffee at Maha



Christmas / Monika's birthday dinner





13 International Journal of Fluid Power

Dear Associate Editors and Members of Editorial Board,

The International Journal of Fluid Power has completed its fourteenth year of publication. The third and final issue of the 14th volume was published this past November. This was the 42nd issue of the Journal, which was published by TuTech.

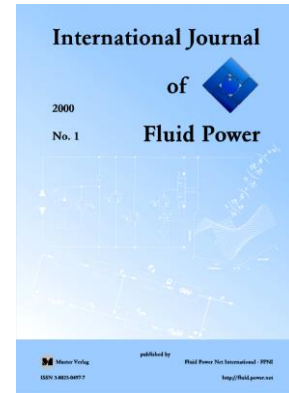

I have an exciting announcement to make. Starting January 1, 2014 the *International Journal of Fluid Power* will be published by Taylor & Francis. This change of the publisher will bring several new features for our authors, reviewers and readers as well as the editorial team. The scope, content and layout of the Journal will remain unchanged, however we might work with Taylor & Francis on a new cover layout later next year. The Journal will have a new website, where past and new issues will be available for downloading. The link to the site is <http://www.tandfonline.com/loi/tjfp20> .

One of the new features is that accepted research papers will be published online ahead of volume and issue allocation within the 'Latest Articles' section on the website. All papers will be copyedited, typeset, assigned a digital object identifier and will be fully citable and downloadable. Authors will receive 50 free electronic offprints of their paper and have perpetual access to their papers within a 'My Authored Works' section of the website. This applies to all authors of a paper and not just the corresponding author. Taylor & Francis will continue to publish printed versions of each issue. Another very important feature is the introduction of an electronic submission site. Taylor & Francis will begin the set up process for the electronic paper submission website, in late March 2014. The site can be customized to the editor's wishes and full training and guidance will be provided to the editorial team.

After sharing these thrilling news with you, I would like to express my gratitude to all members of the editorial board for their continuous support of the Journal. My special thanks goes to all the associate editors who have done an excellent job in managing an increasing number of paper reviews. Without the tremendous support and voluntary work of all associate editors the journal would not be possible.

I would like to thank all reviewers for their great assistance and hard work. Having such a wonderful and knowledgeable group of reviewers has helped to further ensure the work published in the Journal is only of the highest quality. The list of reviewers will be published again in the first issue of 2014.

I am really fortunate to have Susan Gauger as the Journal's technical editor. She has done an incredible great work in organizing the review process, proof reading and production process of the Journal. Please join me in thanking her for her outstanding service and personal care about authors, associate editors, reviewers and customers.

Finally, I want to give recognition to all members of the editorial board for your great assistance and advice.

I would like to add some statistical information regarding the Journal's progress this past year. Since the establishment of the Journal in 2000 we have presented 34 different fluid power software tools and introduced 35 fluid power research center spanning 4 different continents. There have been authors from 34 different countries that have submitted papers to the International Journal of Fluid Power during the last fourteen years. Twenty-six papers were submitted to the journal in 2013. All papers that were received by the Journal were sent to at least two experts and in many cases a third reviewer was involved to ensure the review process is fair and the Journal's final publication is of the highest quality only. The rate of successfully approved papers in the past year was approximately 46%.

We requested the Journal's re-evaluation by the Scientific Citation index this last year. The re-evaluation began in April 2013 and is still in process. I hope that we will be successful this time and I am certain that the change of publisher with all the new features for indexing and citation will help the Journal to achieve this breakthrough.

My appreciation goes to all of you for your continuous support of the Journal. I wish you and your families a wonderful Holiday Season, a happy New Year, and all the best for 2014.

Best regards,



Monika Ivantysynova
Editor-in-Chief

December 18, 2013

14 Maha Team in 2013

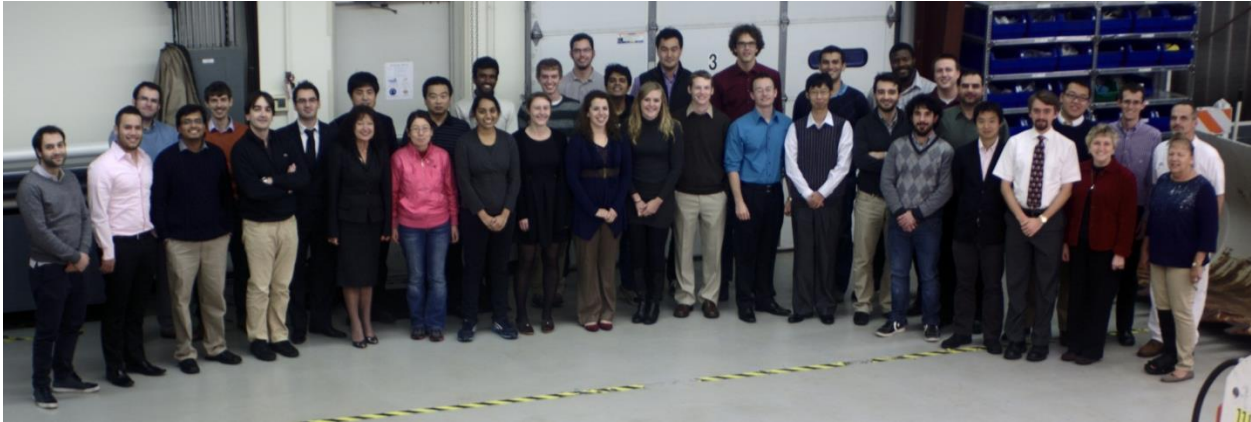

Maha Faculty



Dr. Monika Ivantysynova

Maha Professor of Fluid Power Systems

Joint Appointment in ABE/ME

Supervisor of the Maha Fluid Power Research and Education Center

mivantys@purdue.edu

Phone: (765) 447-1609

Origin: Germany

August 2004-present

Maha Graduate Students



Tyler Bleazard
Master's Student
Phone: (765) 449-7980
BS: Brigham Young
University
Origin: Ottawa, IL
July 2013-present



Enrique Busquets
PhD Student
BS: U. of Texas at El Paso
MS: Purdue University
Phone: (765) 449-7980
Origin: Mexico
July 2011-present



Rene Chacon Portillo
Master's Student
Phone: (765) 449-7514
BS: University of Texas at
El Paso
Origin: Mexico
July 2012-present



Naseem Daher
PhD Student
BS, MS: Lawrence
Technological University
Phone: (765) 418-6665
Origin: Lebanon
Aug 2011-present



Meike Ernst
Master's Student
Phone: (765) 448-1456
BS: Case Western Reserve
University, Cleveland,
Ohio
Origin: Stuttgart,
Germany
July 2013-present



Rohit Hippalgaonkar
PhD Student
B.Tech. : IIT Bombay
M.Eng.: Cornell Univ
Phone: (765) 449-7980
Origin: India
June 2010-present



Paul Kalbfleisch
 PhD Student
 BS: Purdue University
 Phone: (765) 448-1456
 Origin: Kentucky, USA
 Oct 2011-present



Taeho Kim
 PhD Student
 Phone: (765) 448-1456
 BS: Ajou University,
 South Korea
 MS: KAIST, South Korea
 MS: University of Florida
 Origin: S. Korea
 Aug 2012-present



Chenhao Ma
 Master's Student
 Phone: (765) 449-7980
 Origin: China
 May 2013-present



Dan Mizell
 PhD Student
 BS: Michigan Phone:
 (765) 449-7514
 Technological University
 Origin: Michigan, USA
 July 2011-present



Amine Nhila
 PhD Student
 Phone: (765) 449-7980
 BS: UC Berkeley
 MS: U of Illinois at
 Urbana Champaign
 Origin: Casablanca,
 Morocco
 August 2013-present



Damiano Padovani
 PhD Student
 Phone: (765) 449-7980
 BS, MS: Polytechnic
 University of Turin
 Origin: Italy
 August 2012-present



Andrew Schenk
 PhD Student
 BS: Kettering University
 Phone: (765) 449-7514
 Origin: Michigan, USA
 July 2009-present



Lizhi Shang
 PhD Student
 Phone: (765) 448-1456
 BS: Huazhong University
 of Science and
 Technology
 MS: New Jersey Institute
 of Technology
 Origin: China
 January 2013 - Present



Natalie Spencer
Master's Student
Phone: (765) 448-1456
BS: Embry-Riddle
Aeronautical University
Origin: Arlington, WA,
USA
August 2012-present



Michael Sprengel
PhD Student
BS: Missouri S&T
Phone: (765) 418-6665
Origin: Missouri, USA
August 2010-present



Phil St. Hilaire
Master's Student
Phone: (765) 449-7980
BS: Midwestern State
University, Wichita Falls,
Texas
Origin: Island Of
Dominica, Caribbean
July 2013-present



Kyle Williams
PhD Student
Phone: (765) 449-7980
MS: Purdue University
Origin: USA
July 2013-present



Ashley Wondergem
PhD Student
Phone: (765) 448-1456
BS: Saginaw Valley State
University
Origin: Michigan, USA
August 2012-present



Marco Zecchi
PhD Student
BS, MS: Università Degli
Studi di Parma
Phone: (765) 449-7514
Origin: Italy
April 2010 – December
2013

Visiting Researchers



Bjoern Bahl
Visiting Researcher
Phone: (765) 418-1857
B.Sc.: RWTH Aachen
University
Origin: Goettingen,
Germany
September 2013-
December 2013



Dr. Hong Gao
Visiting Scholar
Phone: (765) 448-1456
PhD: Zhejiang University
Origin: China
June 2013-present



Yizhu Gu
Visiting Researcher
BS: Zhejiang University
Origin: China
July 2013-October 2013



Amin Mehdizadeh
Visiting Researcher
BS,MS: Shiraz University
MS: The Royal Institute
of Technology, Sweden
Origin: Iran
Dec. 2011-Aug. 2013

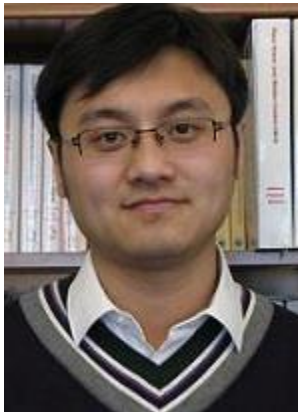

Wei Shen
Visiting Researcher
BS: Northeast Forestry
University
MS: Yan Shan University
PhD: Harbin Institute of
Technology
Origin: China
Feb 2012-Mar 2013



Hideaki Usami
BS, MS: Meiji University
Origin: Japan
Aug 2012-Present

Maha Staff



Anthony Franklin

Lab Manager
Phone: (765) 448-1587
Origin: Kokomo, IN
November 2008-present



Susan Gauger

Maha Secretary/ Assistant
Phone: (765) 448-1587
Origin: Lafayette, IN, USA
June 2011 - present



Connie McMIndes

Inventory Control Clerk
Phone: (765) 448-1587
Origin: Lafayette, IN
October 2012-present

Summer Undergraduate Students



**Jose Edgar Gomez
Gomez**
Undergraduate
Researcher
Origin: Queretaro,
Mexico
May 2013-October 2013



Jordyn Miller
SURF 2013 Student
Origin: USA
May 2013-Aug 2013

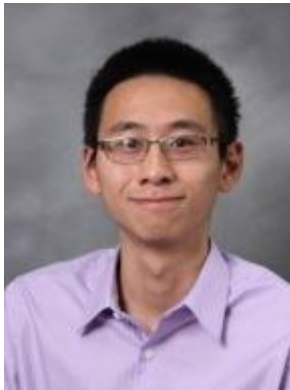

Yangqiao Zheng
SURF 2013 Student
Origin: China
May 2013-Aug 2013

15 Donors, Sponsors, Partners, & Guests

Generous donors, Mr. Ken Warren and his kind wife Susan, support Maha research with \$12,000 every year!

In 2013, Mr. Ken Warren and his wife Mrs. Susan Warren decided to increase their support of Maha research activities with \$12,000 every year. The Maha team delightfully welcomed Ken and Susan to the lab on Friday September 6, 2013. During their visit, they attended the seminar presentation here at Maha and then got to tour the lab facilities and learn more about the available test beds and prototypes. Presenting in this lab tour included Enrique, Natalie, Andrew, Rene, Marco, Dan, Ashley, Mike, Naseem, Kyle and Tyler, Paul, Taeho and Phil, and Rohit and Damiano. After the tour, they were then able to join the Maha team for a relaxing night at Monika's annual dinner party.

Ken has been in fluid power industry for decades and is currently working for Parker Aerospace. We are very proud and pleased to receive this generous personal gift from Ken and Susan and thank them for their support of our fluid power research at Maha. Below is a photo of Ken and Susan.



Industrial Sponsors & Partners

We are proud of and grateful for our newest additions to our list of partners/sponsors. We would like to thank all our partners for their fruitful co-operation and support of our research:

Actia, Toulouse, France	Honeywell Aerospace, South Bend, USA
Airbus Deutschland GmbH, Hamburg, Germany	HYDAC International GmbH, Sulzbach/Saar, Germany
AM General, South Bend, USA	INNAS, Breda, Netherlands
Bobcat, West Fargo, USA	Jungheinrich AG, Norderstedt, Germany
Bosch-Rexroth AG, Elchingen, Germany	Komatsu Ltd., Tokyo, Japan
Bosch-Rexroth Corporation, Sturtevant, USA	Liebherr, USA
B+V (Blohm+Voss) Industrietechnik, Hamburg, Germany	Linde AG, Aschaffenburg, Germany
Borg Warner, Inc., Auburn Hills, Minnesota, USA	Linde Hydraulics Corp, Canfield, USA
Case New Holland, Burr Ridge, Chicago, USA	Mecalac, Annecy-le-Vieux, France
Caterpillar Inc., Peoria, USA	Moog GmbH, Böblingen, Germany
Centro Ricerche Fiat, Orbassano, Italy	Moog Inc., East Aurora, USA
Claas Industrietechnik GmbH, Paderborn, Germany	National Fluid Power Association (NFPA)
Cummins Inc., Columbus, USA	Adam Opel AG, Rüsselsheim, Germany
Doosan Infracore, Seoul, South Korea	Oilgear Towler GmbH, Hattersheim, Germany
Deltrol Fluid Power, Milwaukee, USA	Orenstein & Koppel AG O&K, Berlin, Germany
Evonik Industries, Germany	Parker Hannifin GmbH, Kaarst, Germany
John Deere Product Engineering Center, Waterloo, USA	Parker Hannifin Corp., Cleveland, USA
K. & H. Eppensteiner GmbH & Co. KG, Ketsch, Germany	Quality Control Corporation, Chicago, USA
Eaton Corporation, Eden Prairie, USA	ROSS Controls, Troy, USA
Fairfield Manufacturing, Lafayette, USA	Sauer-Danfoss, Neumünster, Germany
Gates Corporation, Denver, USA	Sauer-Danfoss, Aimes, Iowa, USA
Harsco Rail, South Carolina, USA	Sun Hydraulics, Sarasota, USA
Häggglunds Drives Inc., Columbus, USA	Triumph Group, Inc., Pennsylvania, USA
Hense Systems, Bochum, Germany	TRW Automotive, Lafayette, USA
Honda R&D Americas Inc., Raymond, USA	WIKA Instruments Corporation, Lawrenceville, USA
Hyundai Heavy Industries Co., Korea	ZF Luftfahrttechnik, Kassel, Germany

Visitors & Guests

Paul Engelberth - AGCO

Ravi Godbole - AGCO

Antti Marttinen - AGCO

Muhammad Chandasir Tier - AGCO

Uwe Neumann – Bosch Rexroth

Yashodeep Lonari – Hitachi

Morio Oshina – Hitachi

Shohei Ryu – Hitachi

Kazutaka Okamoto – Hitachi

Nikhil Seera – Hitachi

Yasutaka Tsuruga – Hitachi

Kenji Hiraku – Hitachi

Jae-Cheon Lee – Keimyung University (South Korea)

Ray Collett - Parker

Will Kuyvenhoven - Parker

Kyle Merrill - Parker

Howard Zhang - Parker

Daniel Dyminski - Parker

Jonathan Zhu – Parker

Lewis Kaspar – Parker

Kazushi Ishida – Sumitomo Heavy Industries Ltd.

Hiroshi Ishiyama – Sumitomo Heavy Industries Ltd.

Takashi Iijima – Sumitomo Heavy Industries Ltd.

Koichiro Tsukane - Sumitomo Heavy Industries Ltd.

Ken and Susan Warren – Donors

Harish Narotham – Group Hydraulic Systems

Martyn Molsom - Group Hydraulic Systems

James Barlett – Hagie Manufacturing Company

Heikki Handroos – Finland Lappeenranta University

Mark Slover - Hengli

Seung Hyun Choi - Hyundai Heavy Industries Co., Ltd.

ByungJoo Kim - Hyundai Heavy Industries Co., Ltd.

Harish Narotham – JCB

Martyn Molson – JCB

Naudu Ramani – Fluid Tech

R. Ramani – Fluid Tech

Robert Sikorski – SES Inc.

Dane Davis – SES Inc.

Alan Tehan – SES Inc.

Victor Vargas – Harsco Rail

Brett Brooks – Harsco Rail

Nikhil Seera – Hitachi Construction Machinery

Ryu Shohei – Hitachi Construction Machinery

K. Okamoto – Hitachi Construction Machinery

Kenji Hiraku – Hitachi Construction Machinery

Yasutaku Tsuruga – Hitachi Construction Machinery

Morio Oshina – Hitachi Construction Machinery

Yash Lonari – Hitachi Construction Machinery

Ron Kendzior – Jaquet

Chad Renbarger – Jaquet

Rick Linoner – JNA

Bill Gray - Nevpath

Larry Villasmil Urdaneta – Rochester Institute of Technology

Marcus Geimer - University of Karlsruhe

Acuna - Universidad Tecnológica de Querétaro

Moog

Parker Aerospace

Stored Energy Solutions

ABET Faculty Workshop

Academic Council Retreat School of Ag

Big Ten Expo

Ivy Tech

NSF Site Visit