

Maha Fluid Power

RESEARCH CENTER

PURDUE
UNIVERSITY

2008 Annual Report

Monika Ivantysynova

Maha Professor of Fluid Power Systems

Lafayette, January 2009

Preface

2008 marked the beginning of the third year of our research within the National Science Foundation sponsored Engineering Research Center (ERC) for Compact and Efficient Fluid Power (CCEFP). The CCEFP is a \$21 million fluid power research initiative comprised of 7 collaborating universities. The Center is strongly supported by 60 industrial partners including the National Fluid Power Association. At the Maha Fluid Power Research Center, our research within the CCEFP is focused on new technologies to reduce energy consumption in fluid power systems by 30% or more. The team is concentrating on the development of new system solutions including controls for off-road machinery and power trains. We are also discovering ways to improve the efficiency of pumps and motors which form the heart of any fluid power system. This year we have begun the process of filing a patent for a recent discovery related to improving pump and motor efficiency. In addition to our involvement in the ERC we continued our successful cooperation with industrial partners.

This year I, along with one of my PhD students, travelled to Bath, England for the 2008 Bath ASME Symposium on Fluid Power and Motion Control. From there we continued our journey east to Toyama, Japan for the 7th JFPS International Symposium. I also had the opportunity to take a large portion of my team to the 5th Fluid Power Net International PhD Symposium held in Cracow, Poland. We had a wonderful time reconnecting with old friends and making new ones. In addition, I am happy to report that one of my students was honored with the Backé Best Paper award and two others received honorable mentions.

2008 also marked the successful defense and graduation of four of our master's students. One has currently begun working for Caterpillar and another has elected to stay on with our team for a PhD.

2008 also saw a major transition for us at the Maha lab as we moved from our original location at the INOK building to a very nice, larger facility located in the southeast corner of Lafayette. We currently share the space with Professor Doug Adams and the Purdue Center for Systems Integrity (PCSI). Though causing some minor delays in our research, overall I am pleased to say we had a successful and swift transition to our new location and we are all very happy with the new space.

I would like to thank all team members for their excellent work in 2008. It is a great pleasure to present the following survey of our activities and main achievements during this past year.

I am confident that we will continue our fruitful research. I wish all the members of our team much success during 2009.



Monika Ivantysynova

Maha Professor of Fluid Power Systems



CONTENTS

1	Research Activities	1
2	Research Results & Software Tools	7
3	The New Maha Fluid Power Research Center	15
4	Research Grants	23
5	Industrial Partners & Sponsors	24
6	Publications	25
7	Master's Theses Advised	28
8	International Co-operation	29
9	International and National Conferences Attended	30
10	Awards and Honors	34
11	Maha in the News	35
12	Educational Activities	43
13	Maha Social Events	50
14	International Journal of Fluid Power	53
15	Maha Team in 2008	55
16	Visitors & Guests	64

1 Research Activities

The Center for Compact and Efficient Fluid Power

Much of the research activity in the Maha Fluid Power Research Center is part of a large research effort called the Center for Compact and Efficient Fluid Power (CCEFP). The CCEFP is an Engineering Research Center (ERC) funded by the National Science Foundation inaugurated in 2006. The center is dedicated to advancing research in fluid power science, technology and education. Purdue is one of seven universities represented in the CCEFP. Other participating universities are Georgia Institute of Technology, University of Illinois at Urbana-Champaign, University of Minnesota, Milwaukee School of Engineering, North Carolina A&T State University and Vanderbilt University. Dr. Ivantysynova sits on the center's executive committee and is the leader of Thrust Area 1: Efficiency. The other two thrust areas are Compactness and Effectiveness. Together the three thrust areas support research aimed at overcoming the current technological barriers facing fluid power with the ultimate goal of making fluid power more efficient, compact and quieter. Currently there are five Purdue faculty members as well as their graduate student teams participating in the CCEFP: Monika Ivantysynova, Steven Werely, Steven Frankel, John Lumkes and Ashlie Martini, a recent graduate of Northwestern University who joined Purdue in August 2007. She became the first new ERC faculty hire at Purdue and joins the team with expertise in computational tribology. Along with her PhD student, Jose Garcia, she has begun a new project within the CCEFP, project 1B.2: Surface Effects on Start-up Friction and their Application to Compact Gerotor Motor Design. 2008 also saw the graduation of several ERC students. Najoua Jouini, Andrew Fredrickson, Josh Zimmerman and Jonathan Baker all graduated with their Master's degrees this past year. Josh has decided to stay on at Maha for the PhD and Andrew has since begun working for Caterpillar.

2008 Annual Meeting

The second annual CCEFP conference was held May 26 – 28, 2008 at the Milwaukee School of Engineering in Milwaukee, WI. Purdue was well represented in the proceedings, as the following list of posters and presentations attests.

Presentations

- 1A.2: Optimal Power Management with Displacement-Controlled Actuators, *Christopher Williamson (PhD Student)*
- 1B: A Novel Fluid-Structure Interaction Model for Pumps and Motors, *Matteo Pelosi (PhD Student)*
- 3B.2: Active Vibration Control of Variable Displacement Axial Piston Pumps to Reduce Structureborne Noise, *Jeffrey Peters (MS Student)*
- 3C: Computational and Experimental Studies of Cavitating Hydraulic Flows, *Jeffrey Dougan (MS Student)*
- Test Bed 1: Excavator, *Josh Zimmerman (PhD Student)*

Posters

- 1A.2: Optimal Power Management with Displacement-Controlled Actuators, *Christopher Williamson (PhD Student)*
- 1B: Advanced Surface Design Based on a Fully Coupled Fluid-Structure-Thermal and Multi-Body Dynamics Simulation for a New Generation of Pumps and Motors, *Jonathan Baker (MS Student)*
- Trust 1 – Proposed Project 1B.2: Surface Optimization for Compact Gerotor Motor Design, *Jose Garcia (PhD Student)*
- 3B.2: Active vibration control of variable displacement axial piston pumps to reduce structureborne noise, *Jeffrey Peters (MS Student)*
- 3C: Large Eddy Simulation Techniques for Cavitation, *Aditya Chunekar (PhD Student)*
- Test Bed 1: Excavator, *Josh Zimmerman (PhD Student)*

Industrial Support

Although academic research is the primary focus of the CCEFP, there is considerable support from industrial sponsors. After the 2007 annual meeting in Atlanta, a cadre of industrial representatives was selected to work directly with CCEFP students and faculty to support their research and promote the future transfer of ideas from academia to commercial production. The Purdue team has continued to stay in touch with these “industry champions” through periodic webcasts hosted by the Maha Fluid Power Research Center. Meetings were held on March 3, September 23, and December 9. CCEFP Industrial sponsors and their representatives included:

- Caterpillar: Chris Beaudin, Nadim Chalhoub, Kevin Folland
- Eaton: Clark Fortune, Richard Lyman, Srinivas Patri, Dennis Szulczewski
- Enfield Technologies: Dan Cook
- Gates: Dan Hergert
- HUSCO Intl: Dwight Stephenson
- MTS: Byron Saari
- Sauer Danfoss: Jeff Hansell

Education and Outreach



Sihle at her test-rig

they work with graduate students doing original research. In 2008, the Maha Fluid Power Research Center hosted six REU students:

Educational outreach is another mission of the CCEFP, with programs to promote the teaching of science and technology concepts related to fluid power at the secondary and graduate levels and to encourage participation from underrepresented minorities. The Research Experience for Undergraduates (REU) program places undergraduate engineering students in ERC laboratories for 10 weeks in the summer, where



Ivan at the JIRA

- Nicholas Browdues, Purdue University
- Michael Cross, University of Tennessee at Knoxville
- William Hinson, Purdue University
- Laura Rodriguez, Instituto Tecnologico de Ciudad Juarez
- Ivan Swandono, Purdue University
- Sihle Wilson, Florida A&M University



William working towards a prototype design of the semi-anechoic chamber

Nicholas and Laura worked on developing a new power train test rig under the supervision of Rajneesh Kumar and Shekar Degaonkar. The test rig will be used to test pumps and motors under extreme conditions like in applications for hybrids. Michael worked with Chris Williamson to investigate the energy savings associated with a fluid power system controlled by Independent Metering Valve (IMV) technology. William and Sihle assisted Richard Klop and Jeff Peters with the design and fabrication of the Maha Fluid Power Research Center's new semi-anechoic chamber to be used for research related to noise reduction of pumps, motors and hydraulic transmissions. Ivan worked primarily with the JIRA test rig under the supervision of Edward Hughes.



Mac at the controls of the Bobcat Skid-steer loader

Publicity

The inauguration of an engineering research center devoted to fluid power has generated considerable attention in related academic and industrial circles. The research surrounding displacement control technology applied to the CCEFP Test Bed 1—a Bobcat Mini Excavator—was featured in the October edition of the Tribology and Lubrication Technology journal. Also, the research of Chris Williamson in CCEFP project 1A.2 was featured in the September/October edition of the Fluid Power Journal. Additionally, the work related to pump controlled systems and the recent discoveries in Project 1B.1 were highlighted in Purdue University News and Science-Daily.com.

Research Areas at Maha

Our research activities are focused in two main areas:

- 1) Advanced energy saving hydraulic actuators and drive systems
- 2) Investigation of the physical processes in displacement pumps and motors with a particular interest in modeling the flow phenomena in narrow lubricating gaps.

Research related to the lubricating gaps is primarily supported by the NSF through participation in the CCEFP. Additionally affiliated with the CCEFP is some of our research related to energy saving hydraulic actuators. A more detailed summary of each of our current research areas follows.

Advanced energy saving hydraulic actuators

The aim of this research is to develop new valveless hydraulic actuator concepts including necessary motion control strategies for different applications that avoid energy dissipation by resistance control. Recently a new valveless linear actuator has been developed and successfully tested on an off-road vehicle. For large mobile robots displacement controlled joint rotary actuator concepts have been developed and successfully demonstrated using our JIRA test rig. Currently, work is being done regarding active oscillation damping based on displacement control for off-road vehicles. A Bobcat skid-steer front loader serves as the test vehicle for this research.

Computer based pump & motor design

This research focuses on the performance optimization and noise reduction of pumps and motors. These research efforts have involved the design of special experimental test rigs to develop a fundamental understanding of the complexity of physical effects taking place in displacement machines. One important result of this research on pumps and motors has been the development of the multi-domain simulation program CASPAR. CASPAR (Calculation of Swash Plate Type Axial Piston Pump/Motor) represents the first program worldwide that predicts flow ripple, instantaneous cylinder pressure, oscillating swash plate forces, gap heights, friction forces and volumetric losses of swash plate type piston pumps and motors.

CASPAR is currently undergoing a major update. The aim of the project is to develop a detailed, fully coupled fluid-structure-multi-body model for benchmarking the complex physics of the lubricating gaps in axial piston machines. The interaction between fluid and structure in these type of gaps is very important since, unlike other lubricating gaps, they simultaneously fulfill a sealing and bearing function under oscillating load conditions. The current kernel of CASPAR includes a fluid-structure interaction model and non-isothermal gap flow model for the piston/cylinder and cylinder block/valve plate lubricating gaps. These modules currently exist outside of the iteration loop.

The objective of the current work with CASPAR is to extend to the gaps the Thermal-Elasto-Hydrodynamic (TEHD) lubrication theory which couples the Reynolds Equation, universally used to model film thickness behavior, with the heat transfer to the solid parts (T) and the surface elastic deformation of the solid parts (EHD). In particular, on one side, being able to predict the heat transferred from the lubricating gaps to the solid parts will allow an accurate determination of the boundary temperatures, for a better prediction of the fluid viscosity. The fluid viscosity in

fact is strongly influenced by the temperature distribution and is very important for the gap behavior. On the other side, the surface elastic deformation determined by the dynamic pressure fields generated inside the gap strongly affects the film thickness and therefore the oil load carrying capabilities. The work is currently focused on the development of such a model for the piston/cylinder interface, since this interface is one of the most critical interfaces and special test-rigs (the EHD and OLEMS test-rig) in the lab will allow us to confirm the numerical results. In the future, the model will be extended in a similar fashion to the slipper/swashplate interface and to the cylinder block/valveplate interface.

Using the current kernel of CASPAR, research activities concentrate on developing methods for surface optimization that increase power density and decrease losses in the lubricating gaps. Recently, a patent has been filed for a novel micro-structured surface applied to the cylinder block. Further research focuses on modeling fluid and structure borne noise sources for the purpose of developing model based optimization methods for the reduction of noise emission from pumps and motors. Work is also being done towards developing a model for the prediction of noise in hydrostatic transmissions.

Drive line control of off-road vehicles

Research in this area focuses on investigating the feasibility and performance of alternative drive line technologies for off-road vehicles. The aim is to develop system concepts for minimizing exhaust emissions and fuel consumption without limiting the vehicle's driving power. A special software tool called PSDD (Power Split Drive Design) has been developed to support virtual prototyping of power split drives and complex multi-motor hydrostatic transmissions. The research activities are supported by performance measurements using pump and motor test rigs and a hardware-in-the-loop drive-line test rig. Some past studies include:

- Virtual prototyping of power split drives and hydraulic hybrid power trains
- Advanced system and control strategies for multi-motor hydrostatic transmissions
- Development of generic methods for prognostics of mechatronic systems of off-road vehicles

Maha Research Projects in 2008

In 2008 work has been done on the following research projects:

- Active vibration damping for off-road vehicles using displacement controlled linear actuators
- Optimal power management strategies using displacement controlled actuators
- Development of an elasto-hydrodynamic (EHD) model of the slipper/swash plate for advanced gap flow simulation
- Development of an efficient finite element solver to support the EHD simulation model
- Investigation of the effect of surface shaping on losses in the lubricating gaps of axial piston pumps and motors using CASPAR
- Noise reduction of axial piston machines based on multi-parameter optimization

- Development of a line model for later incorporation into research focusing on noise reduction strategies for hydrostatic transmissions
- Virtual prototyping of power split drives and hydraulic hybrids
- Vehicle drive-line control towards optimized primary power consumption

The described research activities are accompanied by extensive experimental work. During the last ten years a comprehensive fluid power research laboratory has been built complete with pump and motor test rigs, actuator test rigs, drive-line control and transmission test rigs including test machines as well as several specialized test rigs for investigation of tribological systems of displacement machines. A new 180 kW power train test rig has been added to the Maha Fluid Power Research Center. The test rig will be used for testing hydraulic hybrid power trains systems including power train controls.

2 Research Results & Software Tools

Research Reports in 2008

Ivantysynova, M. and Baker, J. 2008. *Modeling a 1 μ m Deep Pocket of width 1mm on either side of the Kidney Ports (DM.2)*. Maha Fluid Power Research Center. Research Report MAHA01-2008-in.

Ivantysynova, M., Zimmerman, J. 2008. *Polymod Tutorial*. Maha Fluid Power Research Center. Research Report MAHA02-2008-in.

Ivantysynova, M. and Baker, J. 2008. *Modeling a 2 μ m Deep Pocket of width 1mm on either side of the Kidney Ports (DM.3)*. Maha Fluid Power Research Center. Research Report MAHA03-2008-in.

Ivantysynova, M. and Baker, J. 2008. *Modeling a 0.5 μ m Deep Pocket of width 1mm on either side of the Kidney Ports (DM.4)*. Maha Fluid Power Research Center. Research Report MAHA04-2008-in.

Ivantysynova, M. and Fredrickson, A. 2008. *A MATLAB Script to Smooth out Pressure Fields*. Maha Fluid Power Research Center. Research Report MAHA05-2008-in.

Ivantysynova, M. and Baker, J. 2008. *Simulation Progress Memo (DM.6)*. Maha Fluid Power Research Center. Research Report MAHA06-2008-in.

Ivantysynova, M. and Baker, J. 2008. *Power Losses for Original, DM.1 and DM.4*. Maha Fluid Power Research Center. Research Report MAHA07-2008-in.

Ivantysynova, M. and Baker, J. 2008. *Calculation of the Maximum and Minimum Gap Height for the Cylinder Block*. Maha Fluid Power Research Center. Research Report MAHA08-2008-in.

Ivantysynova, M. and Baker, J. 2008. *Power Losses for Original, DM.1, DM.4 and DM.6*. Maha Fluid Power Research Center. Research Report MAHA09-2008-in.

Ivantysynova, M. and Baker, J. 2008. *Modeling a 0.5 μ m Deep Pocket on either side of the Kidney Ports (DM.5)*. Maha Fluid Power Research Center. Research Report MAHA10-2008-in.

Ivantysynova, M. and Baker, J. *Progress Memo: DM.7, DM.8, DM.9 (average power losses and max/min gap heights)*. Maha Fluid Power Research Center. Research Report MAHA11-2008-in.

- Ivantysynova, M. and Baker, J.** *A Comparison Between CASPAR Simulation and Measurement Data for the IHAPP Test Rig Pump.* Maha Fluid Power Research Center. Research Report MAHA12-2008-in.
- Ivantysynova, M. and Baker, J.** 2008. *Description of DM.7, DM.8, and DM.9 Simulation Study.* Maha Fluid Power Research Center. Research Report MAHA13-2008-in.
- Ivantysynova, M. and Baker, J.** 2008. *Modeling a 1 μ m Deep Pocket on either Side of the Kidney Ports with a Modified Sealing Land Area (DM.6).* Maha Fluid Power Research Center. Research Report MAHA14-2008-in.
- Ivantysynova, M. and Baker, J.** 2008. *Modifications Made to CASPAR Source Code for Calculating the Wave Structured Surface.* Maha Fluid Power Research Center. Research Report MAHA15-2008-in.
- Ivantysynova, M. and Kumar, R.** 2008. *Measurement Results for Bent-Axis Unit.* Maha Fluid Power Research Center. Research Report MAHA16-2008-in.
- Ivantysynova, M. and Baker, J.** 2008. *Modeling a Wave Structured Surface of 2 Micron Amplitude with 10 Oscillations (DM.7).* Maha Fluid Power Research Center. Research Report MAHA17-2008-in.
- Ivantysynova, M. and Baker, J.** 2008. *Torque and Volumetric Loss Plots.* Maha Fluid Power Research Center. Research Report MAHA18-2008-in.
- Ivantysynova, M. and Baker, J.** 2008. *Contribution of Gaps to Total Power Loss/Efficiency.* Maha Fluid Power Research Center. Research Report MAHA19-2008-in.
- Ivantysynova, M. and Baker, J.** 2008. *Comparing shifting velocities calculated from CASPAR to shifting velocities calculated from gap height/position data.* Maha Fluid Power Research Center. Research Report MAHA22-2008-in.
- Ivantysynova, M. and Baker, J.** 2008. *Modifications Made to CASPAR Source Code for Calculating the Wave Structured Surface for the Slipper.* Maha Fluid Power Research Center. Research Report MAHA24-2008-in.
- Ivantysynova, M. and Baker, J.** 2008. *Simulation Results from a Wave Structured Surface applied to the Slipper (DM.16).* Maha Fluid Power Research Center. Research Report MAHA25-2008-in.
- Peters, J.** 2008. *Active Control of Swash Plate Vibration of Hydraulic Pumps.* Maha Fluid Power Research Center. Research Report MAHA26-2008-in.
- Ivantysynova, M. and Baker, J.** 2008. *DM.8 and DM.9 vs. Standard: Simulation Results.* Maha Fluid Power Research Center. Research Report MAHA27-2008-in.

- Ivantysynova, M. and Baker, J.** 2008. *Wave Structured Surface Simulation Results: DM.12 vs. DM.9 and Standard.* Maha Fluid Power Research Center. Research Report MAHA28-2008-in.
- Ivantysynova, M. and Baker, J.** 2008. *Wave Structured Surface Simulation Results: The Effect of Amplitude (Standard, DM.9, DM.13, and DM.14).* Maha Fluid Power Research Center. Research Report MAHA29-2008-in.
- Ivantysynova, M. and Baker, J.** 2008. *Wave Structured Surface Simulation Results: The Effect of Frequency (Standard, DM.9, DM.11, and DM.15).* Maha Fluid Power Research Center. Research Report MAHA30-2008-in.
- Ivantysynova, M. and Garrett, R.** 2008. *Tribo-Rig Friction Force Project Repeat and Replication study of MAHA Tribo-Rig Done 9-20-08.* Maha Fluid Power Research Center. Research Report MAHA31-2008-in.
- Ivantysynova, M. and Baker, J.** 2008. *A Qualitative Comparison Between CASPAR October 2007 release and CASPAR September 2008 release.* Maha Fluid Power Research Center. Research Report MAHA32-2008-in.
- Ivantysynova, M. and Klop, R.** 2008. *Insufficient Suction Flow Measurements.* Maha Fluid Power Research Center. Research Report MAHA36-2008-in.
- Ivantysynova, M. and Baker, J.** 2008. *Illustrations of the Waved Structured Surface.* Maha Fluid Power Research Center. Research Report MAHA38-2008-ex.

Software Tools

The following special simulation software tools have been developed and are available for commercial use.

CASPAR

The simulation model, *CASPAR* (Calculation of Swash Plate Type Axial Piston Pump/Motor), is a model for predicting the performance and losses of swash plate type axial piston pumps and motors considering specific machine geometry and operating conditions. The program is based on a non-isothermal gap flow model considering the change of gap heights due to micro-motion of parts and due to surface deformation for the connected gaps of a swash plate axial piston machines. The program calculates the flow ripple at both ports, the instantaneous cylinder pressure, the internal and external volumetric losses, viscous friction forces, gap heights, oscillating forces and moments exerted on the swash plate. The model has been developed to meet the need of the next generation of pump and motor researchers and designers and represents a powerful design tool for this kind of displacement machine.

CASPAR describes the flow of a compressible and viscous fluid from the ports through the valve plate to the displacement chamber. It further considers non-isothermal gap flow through each of the three lubricating gaps that seal the displacement chamber. The change of pressure in the displacement chamber resulting from the basic working process of the displacement machine causes fluctuating forces and moments leading to oscillating micro-motion of moveable parts of the rotating group which are considered by the model. For the gap flow calculation, *CASPAR* considers a balance between external and fluid forces, i.e. full film lubrication. No mixed friction model is present. Additionally, the model neglects any surface roughness of the solid parts, assuming ideally smooth sliding surfaces. Models implemented and solved in *CASPAR* consider the time dependent change of gap heights due to oscillating forces, the interaction between machine parts, the dependency on design and operating parameters and the energy dissipation within the gaps.

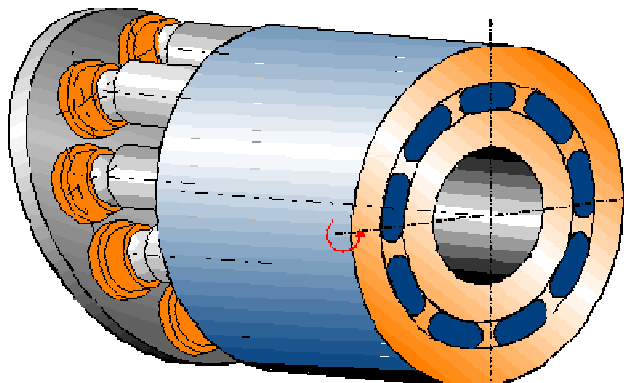

CASPAR also considers the influence that surface deformation of parts forming the gaps has on machine performance and behavior. The mathematical description of the fluid flow from the ports to the displacement chamber and through the sealing and bearing gaps leads to a system of partial and ordinary differential equations. A new numerical method based on iterative coupling of separate solvers for fluid/solid domains has been developed to solve this transient nonlinear system consisting of the Reynolds equation and the energy equation for the fluid domain, the equation of elasticity for the solid domain and the determination of gap heights by solving the motion equation of the multi-body system of the rotating group. The initial boundary conditions such as instantaneous cylinder pressure are obtained by solving the fluid flow from the displacement chamber to the ports.

The model is continuously under development with the aim of achieving a fully coupled, multi-domain model that accurately predicts the gap height. Since 2005, the ability to predict the performance of a spherical port plate and a more comprehensive fluid property model has been added. Further updates of the software have included a more accurate description of a pump with a variable piston gap length. This past year, an EHD model for this slipper has been developed as well as a model for considering non-isothermal flow in the cylinder block/valve plate interface. *CASPAR* is currently undergoing a major update. The updated program promises to be more efficient and will incorporate the EHD and non-isothermal gap flow models for the three considered lubricating gaps within the internal calculation loop. *CASPAR* is a stand-alone tool developed using the C++ programming language.

POLYMOD

The prediction of losses of fluid power systems by numerical simulation and the design of energy saving actuators and drive systems require a very high accuracy in steady state models of components, especially displacement machines. In the past a number of different mathematical models for the description of the loss behavior of displacement machines were developed by many authors. Nearly all available models are based on measurements, but different methods are applied to obtain an analytical description. The limitation of achievable accuracy of most of these models is given by the use of relatively simple analytical expressions, whereas a good fit with measured curves is usually obtained only in a limited area of operating parameters. The program *POLYMOD* uses a pure mathematical modeling approach by interpolating measured steady state characteristics of displacement machines. The use of polynomial fitting of measurement points creates higher model accuracy, especially in the range of boundary operating parameters. *POLYMOD* generates an analytical description of volumetric and torque losses of displacement machines for pumping and motoring mode in all four quadrants of operation based on measured steady state characteristics. The dependency of all important operating parameters such as pressure difference, speed, displacement volume and temperature can be easily considered. *POLYMOD* can be applied to any displacement machine. The software tool is Matlab-based.

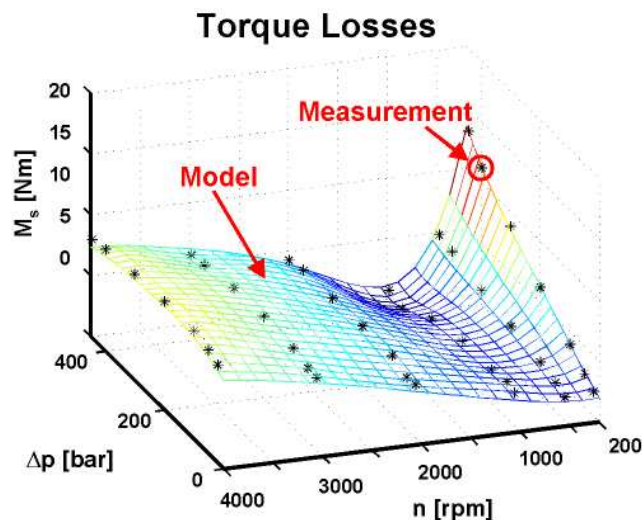

PSDD - Power Split Drive Simulation

One of the main reasons for the use of power split drives in many applications is the possibility to have a continuously variable transmission with simultaneously high efficiency in a wide range of operating parameters. This requires the consideration of real loss behavior of all parts of the transmission. Due to the strong dependence of losses of displacement machines on operating parameters the integration of precise loss models is necessary. The *PSDD* software tool allows for the calculation of system parameters including power losses in the whole range of operation for any kind of power split drive structure. This provides the design engineer with very good support during the design process and helps him to find an optimal structure of the power split drive. The tool has libraries for hydrostatic components, gears, clutches, planetary gear sets, engine and accumulator models. These libraries can be extended and completed by the user easily. An open database of the most common structures of power split drives is implemented in the CAE tool. The *PSDD* software tool is built in a modular way on the Matlab and Simulink platforms.

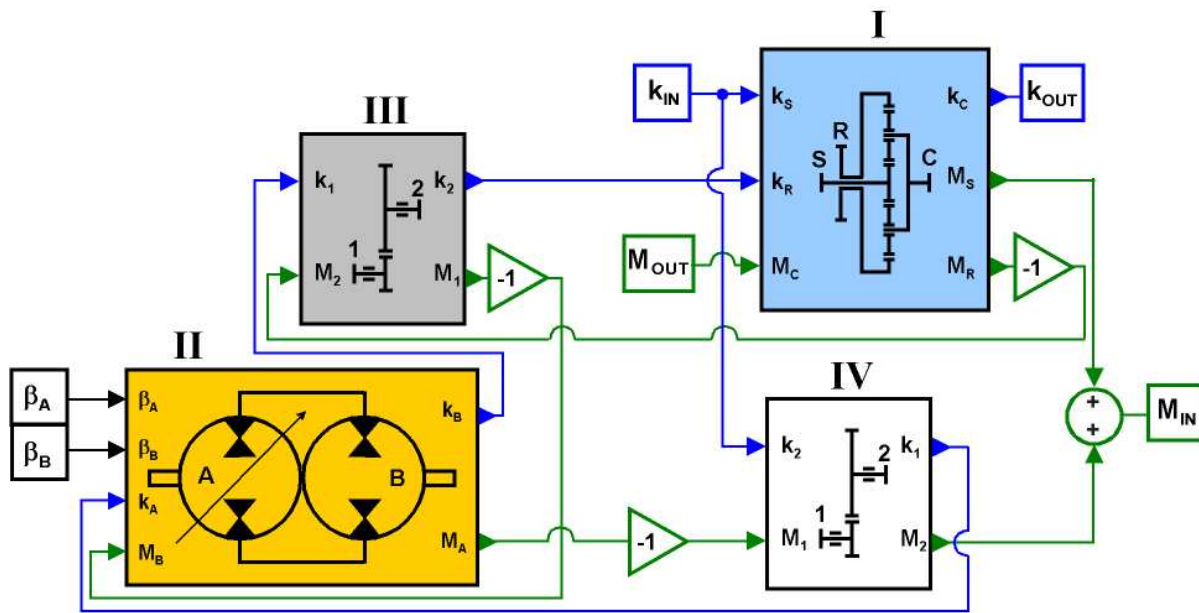

I: Planetary Gear Simulink model

II: Hydrostatic Transmission Simulink model

III: Gear Simulink model

IV: Gear Simulink model

AVAS

The change of pressure in the displacement chamber of a displacement machine is greatly influenced by the small cross-section of the fluid flow which is formed by the valve plate and the rotating cylinder block. For simulation calculations, it is important to know the exact size of the flow passage opening to the high and low-pressure side, depending on the angle of rotation. Because of the complex geometric sectioning, an analytical description of the cross-section is not possible. In the past the cross-section was measured and interpolated manually to obtain the area profile. Using a 3D-model of the valve plate AVAS is able to compute the smallest cross-section of the fluid for a complete revolution of the cylinder block automatically. In the single-step mode every calculated passage area can be visualized. AVAS uses *Unigraphics* based routines to determine the smallest cross-section into the estimated flow direction. The program is written in C++ and uses the UG/Open++ interface to start as an internal application in *Unigraphics*. The 3D-model of the valve plate can be imported from any other CAD-System by the STEP interface.

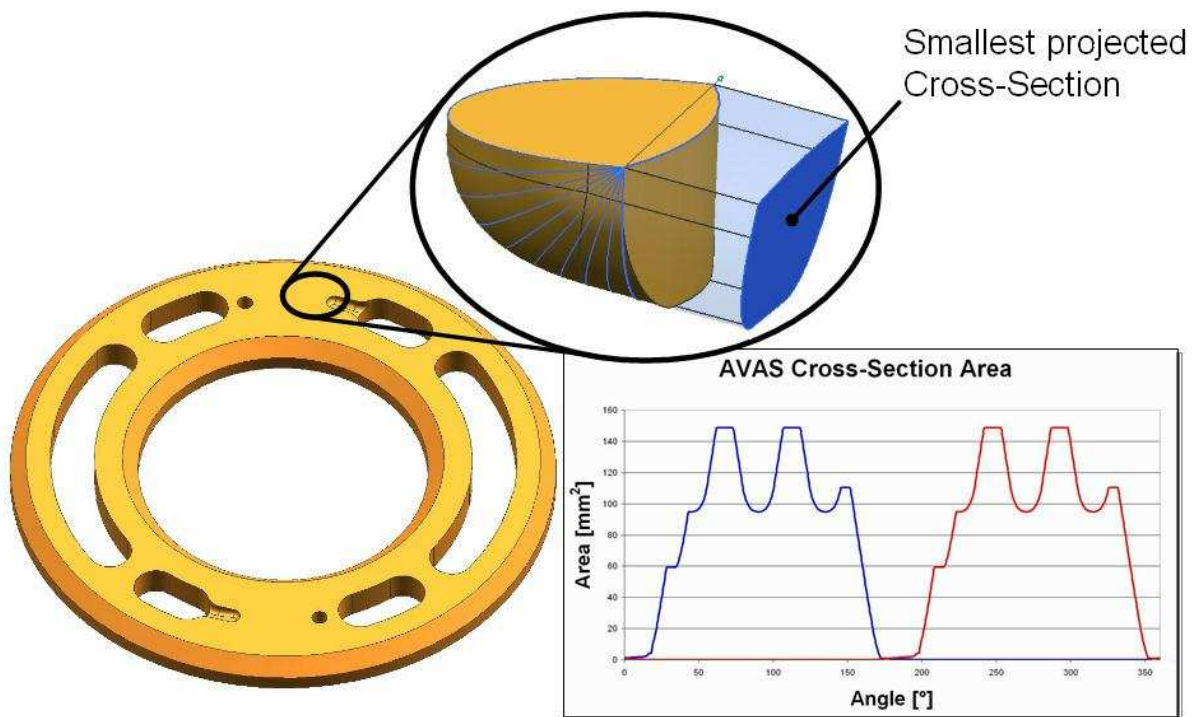

SUEZ

SUEZ automatically creates a design of valve plate openings by reading a corresponding opening area file. *SUEZ* is based on the 3D CAD System *Unigraphics*. The pilot control notches of the valve plate are assumed to be manufactured by ball end milling. The cross section area, the length and the angle of the notches can be manipulated to obtain the desired instantaneous cylinder pressure for given operating parameters. The combination of the simulation tools *CASPAR*, *AVAS* and *SUEZ* allows for an optimization of swash plate axial piston machines in a very cost effective way. This method can also be used for other displacement machines.

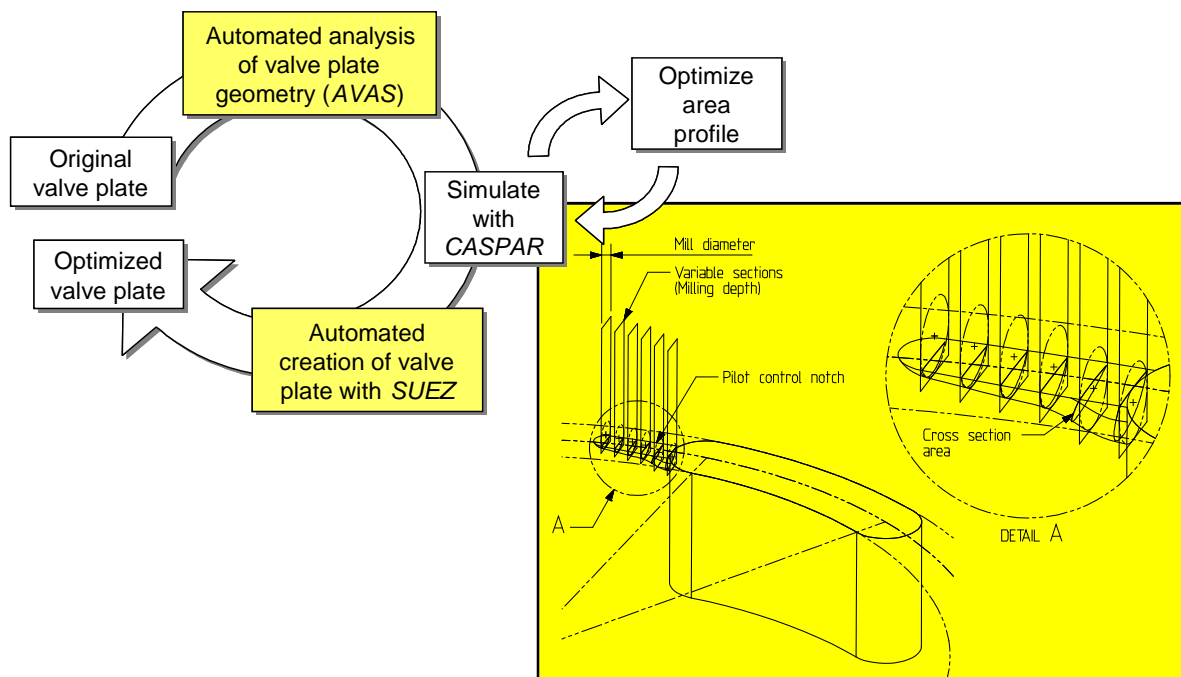

3 The New Maha Fluid Power Research Center



The new face of Maha Fluid Power research: 1500 Kepner Dr.

The Maha Fluid Power Research Center at Purdue University offers a unique and well equipped laboratory for steady state and dynamic measurements on pumps, motors, hydrostatic transmissions, hydraulic hybrid power trains and linear and rotary actuators. At the turn of this past year,



New Maha Lab conference room

it had become apparent that the Maha Fluid Power Research Center was beginning to outgrow its original location at the INOK building. This past June the Maha Fluid Power Research Center moved from its original location to a new, larger facility on the southeast side of Lafayette. The new lab boasts significantly more lab and office space, and has the added bonus of windows, for which all Mahites are very grateful. The total space is up from 12,000 sqft to 19,000 sqft. The lab space itself has been increased from 8,500 sqft at INOK to 12,000 sqft at our new location. With all the new space, especially in the lab,

two new test rigs, on top of the existing seven, have been added. One of the new rigs will support power train research and another—a semi-anchoic chamber—will support the research in noise reduction of pumps, motors and transmissions. Several more features the new space affords are a large conference room for industry and regular internal lab meetings, a break room and dressing and shower facilities. The increased office space has also made it possible for the Maha team to work together in a single room, facilitating a more congenial work atmosphere and further collaboration amongst the group members.



The break room

Different special test rigs are available for experimental investigations of hydrostatic pumps and motors, such as tribological systems, efficiency tests, control systems and lubricating gap temperature and pressure field measurement. A 320 kW central hydraulic power supply unit with

a 2000 liter tank, a water cooler and heating elements with five individually controlled pressure compensated pumps, 350 bar and 450 lpm output flow and a 60 l/min low pressure pump has been installed in 2005. A second medium pressure 64 kW hydraulic power supply, with a maximum flow rate of 250 l/min and pressure differential of 100 bar, has also been added. This supply is equipped with a 500 liter tank. The central pressure net is mainly used to supply hydraulic load units for the individual test rigs, where the load units are based on secondary control. The total installed electric power amounts to 1200 kW. The lab includes 9 test beds and several mobile test machines allowing for the testing of new actuators and drive technologies as well as prognostic methods during practical field tests.

The Maha Fluid Power Research Center was established at Purdue University in the Fall of 2004.

Moving to the Kepner Building

Below are a few before-and-after shots of our new lab space. We were all initially very impressed with and have since very much appreciated and are proud of our new building.



Future home of Maha researchers



The lab space



The Maha research office



The lab space all moved in

Test Rig Overview

The lab currently houses nine test rigs designed to support our research.



EHD test rig

The EHD test rig is designed to measure the dynamic pressure field in the gap between piston and cylinder and the surface temperature distribution in the cylinder of a swash plate axial piston pump. A special test pump with a single piston cylinder assembly has been designed for this test rig.

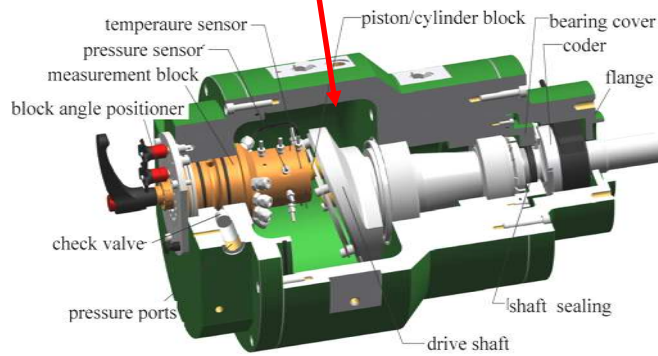

EHD Pump

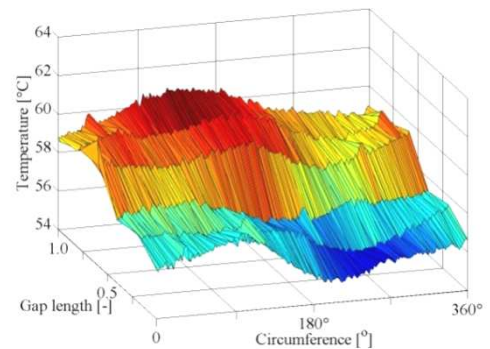

Measured Temperature Field in the Piston/Cylinder Gap



OLEMS test rig

This rig is designed to investigate the temperature behavior in swash plate axial piston pumps. Sixty thermocouples are mounted around a single cylinder to measure the temperature field during operation of the pump. Telemetry is used for data transfer from the rotating cylinder block to the data acquisition board. The measured results are used for the development of a more precise method to calculate the non-isothermal gap flow between piston and cylinder in swash plate type axial piston machines.

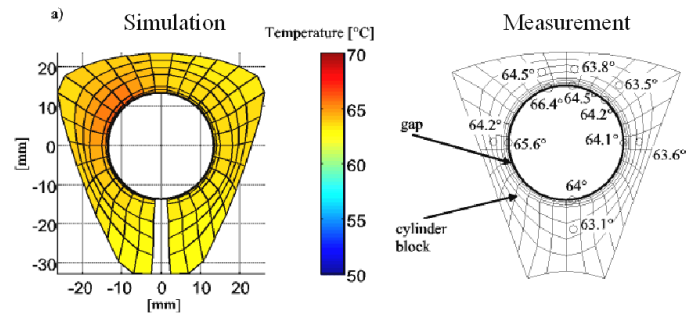
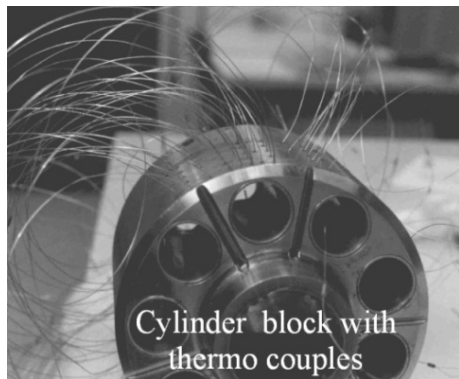

Temperature distribution in the assembly near the slipper side



Tribo test rig

The heart of the test rig, the Tribopump, is designed to measure the dynamic axial and the circumferential friction force between the piston and cylinder. The data can be processed during high speed using a telemetry system. The Tribopump can be operated in either pumping or motoring mode from 1 rpm up to 1800 rpm. The measurements can be taken during steady state conditions at different oil viscosities.

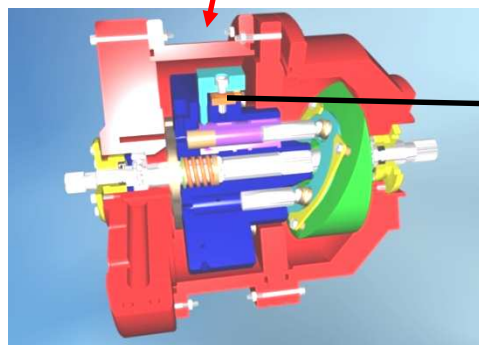

Tribo pump - Hydrostatic bearing (red)

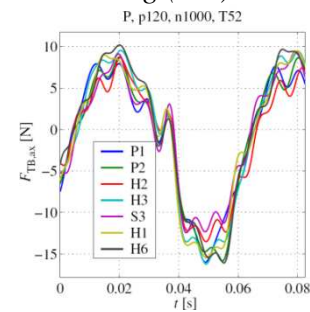
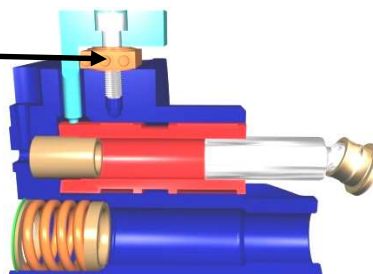



Cavitation/PIV test rig

This test rig was designed to visualize and conduct Particle Image Velocimetry (PIV) analysis of cavitation in hydraulic oil. This test rig was designed in support of CCEFP project 3C and will support the computational studies in modeling cavitation in hydraulic components.



Transmission test rig

The test rig is designed to determine the efficiency of a hydrostatic car transmission at different loads and gear ratios. The transmission is driven by a diesel engine and a secondary controlled unit simulates the driving resistance of the vehicle.



Test rigs for steady state measurements

Two electric motor driven test rigs have been designed to measure steady state and dynamic characteristics for different pump and motor types including 1 rpm tests. The test rigs are equipped with temperature and pressure sensors as well as speed, flow and torque meters.

Performance Characteristics

Max. installed electric power: 2 x 120 kW

Max. speed: $n_1 = 7000 \text{ rpm}/n_2 = 3000 \text{ rpm}$

Max. pressure: 450 bar

Max. torque: $M_1 = 300 \text{ Nm}/ M_2 = 500 \text{ Nm}$



JIRA test rig

The joint rotary actuator test rig (JIRA) has been built for experimental investigations of displacement controlled rotary actuators for use as end effector drives in mobile robots and large manipulators. The developed system and control concepts can also be used for applications such as stabilizers in cars or ships.

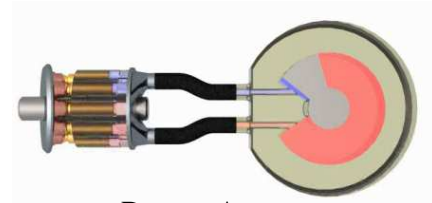

Performance

Max. Torque: 30000 Nm

Max. Pressure: 350 bar

Max. Power: 30 kW

Two new test rigs have been added to facilities at the Maha Fluid Power Research Center. One is designed for the purpose of testing new power trains developed here in the lab. Another is a semi-anechoic chamber to support the research related to noise reduction in pumps, motors and transmissions.



Semi-Anechoic Chamber – under construction

This test rig is designed for noise measurements on pumps, motors and hydrostatic transmissions. The noise measurements are used to support the research in noise reduction conducted at the Maha lab. Though the walls for the chamber are still in the process of being constructed, this test rig has been used to take preliminary noise measurements.



Power Train test rig

This test rig has been designed for the purpose of testing power trains and power train control concepts developed here at the Maha lab.

Test Beds

In addition to the standard test rigs, the Maha Fluid Power Research Center also houses several vehicles that either have been used or are being used currently as a platform for demonstrating and/or investigating new fluid power systems concepts.



Front Wheel Loaders

Displacement control, the concept of controlling hydraulic actuators with variable displacement pumps instead of throttling valves, was first tested and demonstrated using this front wheel loader. Due to the elimination of throttling valves, displacement control technology is also sometimes referred to as “valveless” technology.



This smaller front wheel loader serves as a platform for diagnostics and prognostics on hydraulic systems.



Bobcat Skid-Steer Loader

Pump-controlled technology has also been demonstrated on compact machinery. A Bobcat skid-steer loader has been modified so that the boom and bucket functions are controlled by variable displacement hydraulic pumps. Current research focuses on improving operator comfort and productivity via active vibration damping

Bobcat Mini Excavator

The excavator is being used for the purpose of testing displacement controlled technology and engine power management concepts developed here at the Maha lab. The excavator serves as the CCEFP test bed 1.



4 Research Grants

Research grants obtained in 2008: \$ 892,296 and \$ 1,079,182 pending

Engineering Research Center for Compact and Efficient Fluid Power.

NSF + industry 3rd year funding: \$ 892,296

Robust Active Ride Control System for Bobcat Skid-Steer Loader.

Parker Hannifin Corp: \$ 153,379 - pending

Power Split Transmission for special Truck Application .

Parker Hannifin Corp. \$ 88,476 - pending

Performance Prediction and Control for Efficient and Quiet Series Hydraulic Hybrid Vehicles.

EPA \$ 837,327 - pending

5 Industrial Partners & Sponsors

We are proud of and grateful for our newest additions to our list of partners/sponsors. We would like to thank all our partners for their fruitful co-operation and support of our research:

Actia, Toulouse, France
Airbus Deutschland GmbH, Hamburg, Germany
AM General, South Bend, USA
Bobcat, West Fargo, USA
Bosch-Rexroth AG, Elchingen, Germany
Bosch-Rexroth Corporation, Sturtevant, USA
B+V (Blohm+Voss) Industrietechnik, Hamburg, Germany
Borg Warner, Inc., Auburn Hills, Minnesota, USA
Case New Holland, Burr Ridge, Chicago, USA
Caterpillar Inc., Peoria, USA
Centro Ricerche Fiat, Orbassano, Italy
Claas Industrietechnik GmbH, Paderborn, Germany
Cummins Inc., Columbus, USA
Deltrol Fluid Power, Milwaukee, USA
John Deere Product Engineering Center, Waterloo, USA
K. & H. Eppensteiner GmbH & Co. KG, Ketsch, Germany
Eaton Corporation, Eden Prairie, USA
Fairfield, Lafayette, USA
Gates Corporation, Denver, USA
Hägglunds Drives Inc., Columbus, USA

Hense Systems, Bochum, Germany
Honda R&D Americas Inc., Raymond, USA
HYDAC International GmbH, Sulzbach/Saar, Germany
INNAS, Breda, Netherlands
Jungheinrich AG, Norderstedt, Germany
Linde AG, Aschaffenburg, Germany
Linde Hydraulics Corp, Canfield, USA
Mecalac, Annecy-le-Vieux, France
Moog GmbH, Böblingen, Germany
Moog Inc., East Aurora, USA
National Fluid Power Association (NFPA)
Adam Opel AG, Rüsselsheim, Germany
Oilgear Towler GmbH, Hattersheim, Germany
Orenstein & Koppel AG O&K, Berlin, Germany
Parker Hannifin GmbH, Kaarst, Germany
Parker Hannifin Corp., Cleveland, USA
Quality Control Corporation, Chicago, USA
ROSS Controls, Troy, USA
Sauer-Danfoss, Neumünster, Germany
Sauer-Danfoss, Aimes, Iowa, USA
Sun Hydraulics, Sarasota, USA
TRW Automotive, Lafayette, USA
WIKA Instruments Corporation, Lawrenceville, USA
ZF Luftfahrttechnik, Kassel, Germany

6 Publications

Refereed Conference Proceedings

- Baker, J. and Ivantysynova, M.** 2008. Investigation of Power Losses in the Lubricating Gap Between Cylinder Block and Valve Plate of Axial Piston Machines. *Proc. 5th Fluid Power Net International PhD Symposium*. Cracow, Poland, pp. 302 – 19. **Backé Best Paper Award**
- Fredrickson, A. and Ivantysynova, M.** 2008. A Study of Gap Flow Conditions Between the Piston and Cylinder of an Axial Piston Pump. *Proc. 5th Fluid Power Net International PhD Symposium*. Cracow, Poland, pp. 273 – 84.
- Jouini, N. and Ivantysynova, M.** 2008. Valve Plate Surface Temperature Prediction in Axial Piston Machines. *Proc. 5th Fluid Power Net International PhD Symposium*. Cracow, Poland, pp. 95 – 110.
- Ivantysynova, M.** 2008. Innovations in Pump Design – What are future directions?. *Proceedings of the 7th JFPS International Symposium on Fluid Power*, Toyama 2008, pp. 59 – 64. Invited Lecture organized session agriculture and mining machinery.
- Klop, R. and Ivantysynova, M.** 2008. Investigation of Noise Source Reduction Strategies in Hydrostatic Transmissions. *Proc. 5th Fluid Power Net International PhD Symposium*. Cracow, Poland, pp. 63 – 76.
- Klop, R. and Ivantysynova, M.** 2008. Influence of Line Length Concerning Noise Source Generation in Hydrostatic Transmission. *2008 SAE International Commercial Vehicle Engineering Congress & Exhibition*, Rosemont, IL, USA. SAE Technical Paper 2008-01-2722.
- Kumar, R. and Ivantysynova, M.** 2008. Towards an Optimal Energy Management Strategy for Hydraulic Hybrid Powertrains Based on Output – Coupled Power Split Principle. *Proc. 5th Fluid Power Net International PhD Symposium*. Cracow, Poland, pp. 41 – 51.
- Pelosi, M. and Ivantysynova, M.** 2008. A New Fluid – Structure Interaction Model for the Slipper – Swash Plate Interface. *Proc. 5th Fluid Power Net International PhD Symposium*. Cracow, Poland, pp. 219 – 36
- Seeniraj, G. and Ivantysynova, M.** 2008. Noise Reduction in Axial Piston Machines Based on Multi – Objective Optimization. *Proc. 5th Fluid Power Net International PhD Symposium*. Cracow, Poland, pp. 111 – 23.
- Seeniraj, G. and Ivantysynova, M.** 2008. Multi-objective Optimization for Noise Reduction in Axial Piston Machines. *2008 SAE International Commercial Vehicle Engineering Congress & Exhibition*, Rosemont, IL, USA. SAE Technical Paper 2008-01-2723.

Williams, K. and Ivantysynova, M. 2008. Towards an Optimal Energy Management Strategy for Hybrid Hydraulic Powertrains Based on Dual Stage Power Split Principle. *Proc. 5th Fluid Power Net International PhD Symposium*. Cracow, Poland, pp. 27 – 40.

Williamson, C. and Ivantysynova, M. 2008. Pump Mode Prediction for Four-quadrant Velocity Control of Valveless Hydraulic Actuators. *Proceedings of the 7th JFPS International Symposium on Fluid Power*, Toyama 2008, Vol. 2, pp.323-328.

Williamson, C., Zimmerman, J. and Ivantysynova, M. 2008. Efficiency Study of an Excavator Hydraulic System Based on Displacement-Controlled Actuators. *Bath/ASME Symposium on Fluid Power and Motion Control (FPMC 2008)*, pp. 291-307.

Zimmerman, J. and Ivantysynova, M. 2008. The Effect of System Pressure Level on the Energy Consumption of Displacement Controlled Actuator Systems. *Proc. 5th Fluid Power Net International PhD Symposium*. Cracow, Poland, pp. 77 – 92.

Other Publications

Williams, K., Kumar, R. and Ivantysynova, M. 2008. Robust Control for a Dual Stage Power Split Transmission with Energy Recovery. *Proceedings of the 6th International Fluid Power Conference (6.IFK)*, Dresden, Vol. 1, pp.127-144.

Invited Lectures

IT enabling advancement in Mechanical Engineering. KITARA Seminar, Academia of Finland, September 9, 2008.

Fuel savings through advanced fluid power systems. ICAR Seminar, Clemson University, October 29, 2008.

Advanced surface design based on a fully coupled fluid-structure-thermal and multi-body dynamics simulation model for a new generation of pumps and motors. School of Chemical Engineering Dow Graduate Seminar Series, Purdue University, November 11, 2008.

Posters Presented

2008 ERC Annual Spring Conference, May 26 – 28, 2008. Milwaukee.

Optimal Power Management with Displacement-Controlled Actuators (project 1A.2)
Christopher Williamson

Advanced Surface Design Based on a Fully Coupled Fluid-Structure-Thermal and Multi-Body Dynamics Simulation for a New Generation of Pumps and Motors (project 1B)
Jonathan Baker

Surface Optimization for Compact Gerotor Motor Design (proposed project 1B.2)

Jose Garcia

Active vibration control of variable displacement axial piston pumps to reduce structureborne noise (project 3B.2)

Jeffrey Peters

Large Eddy Simulation Techniques for Cavitation (project 3C)

Aditya Chunekar

Excavator (Test Bed 1)

Josh Zimmerman

5th Fluid Power Net Intl PhD Symposium, July 1 – 5. Cracow, Poland.

Mini-Excavator Performance Prediction and Verification through Experiment

Edward Hughes

Modeling of Bent Axis Axial Piston Machines – New Approach

Daniel Dyminski

7th JFPS International Symposium on Fluid Power, September 15 – 18. Toyama, Japan.

Pump Mode Prediction for Four-Quadrant Velocity Control of Valveless Hydraulic Actuators

Christopher Williamson and Monika Ivantysynova

Patents Filed

Patent application 65083 P1.US - Axial Sliding Bearing with Structural Sliding Surface

Patent application 65225 P1.US - Displacement-Controlled Hydraulic System for Multi-Functional Machines” US provisional Application Serial # 61/111,752

Patent application 65226 P1.US – System and method for blade level control of earthmoving machines. US provisional Application Serial # 61/111,745

Patent application 65227 P1.US - System and method for enabling floating of earthmoving implements. US provisional Application Serial # 61/111,746

Patent application 65230 P1.US – Control System and method for pump-controlled cylinder cushioning. US provisional Application Serial # 61/111,748

Patent application 65224 P1.US - Displacement-Controlled Actuator System for Multi-Functional Machines”

7 Master's Theses Advised

Jouini, N. 2008. *SURFACE TEMPERATURE PREDICTIONS IN AXIAL PISTON MACHINES.*

Fredrickson, A. 2008. *A STUDY OF THE PISTON AND CYLINDER INTERFACE OF AN AXIAL PISTON PUMP USING AN ADVANCED COMPUTER MODEL.*

Zimmerman, J. 2008. *DESIGN AND SIMULATION OF AN ENERGY SAVING DISPLACEMENT-CONTROLLED ACTUATION SYSTEM FOR A HYDRAULIC EXCAVATOR.*

Baker, J. 2008. *POWER LOSS IN THE LUBRICATING GAP BETWEEN CYLINDER BLOCK AND VALVE PLATE OF SWASH PLATE TYPE AXIAL PISTON MACHINES.* Research Report MAHA38-08-ex.

8 International Co-operation

Our successful international co-operations with fluid power research centers worldwide could be strengthened by using our membership in the international network “Fluid Power Net International” (FPNI), which is currently joined by members from 26 countries, refer to <http://fluid.power.net>

International students and researchers

In 2008, the following international students and researchers have worked in our team



Takayoshi



Najoua



Donatien

Takayoshi Ichianagi, National Defense Academy Tokyo, Japan (tichian@purdue.edu)

Najoua Jouini, Universität Stuttgart, Germany (njouini@purdue.edu)

Donatien Keho, France (kelassemaye@yahoo.fr)

Marcel Tkocz, Technical University Dresden, Germany (mail@tkocz.net)

Andrea Vacca, Università Degli Studi di Parma, Assistant Prof. of Industrial Engineering (andrea.vacca@unipr.it)

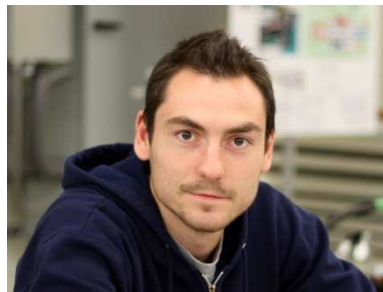

Marcel



Andrea

Visitors from Abroad

Professor Massimo Milani, University of Modena and Reggio. Emilia, Italy.

Federica Franzoni, University of Modena, Italy

Luca Montorsi, University of Modena, Italy

9 International and National Conferences Attended

6th International Fluid Power Conference. Dresden, Germany. April 1 – 2, 2008.

Attendees: Monika Ivantysynova
Kyle Williams (Presenter)

2nd CCEFP Annual Conference. Milwaukee, Wisconsin. May 26 – 28, 2008.

Attendees: Monika Ivantysynova (Thrust 1 Leader)
Chris Williamson (Project 1A.2 Presenter and Poster Presentation)
Matteo Pelosi (Project 1B Presenter)
Jonathan Baker (Project 1B Poster Presentation)
Jeff Peters (Project 3B.2 Presenter and Poster Presentation)
Josh Zimmerman (Test Bed 1 Poster Presentation)

5th Fluid Power Net International PhD Symposium. Cracow, Poland. July 1 – 5, 2008.

Attendees: Monika Ivantysynova
Jonathan Baker (Presenter)
Daniel Dyminski (Poster Presentation)
Andrew Fredrickson (Presenter)
Edward Hughes (Poster Presentation)
Najoua Jouini (Presenter)
Richard Klop (Presenter)
Rajneesh Kumar (Presenter)
Matteo Pelosi (Presenter)
Ganesh Seeniraj (Presenter)
Kyle Williams (Presenter)
Chris Williamson
Josh Zimmerman (Presenter)

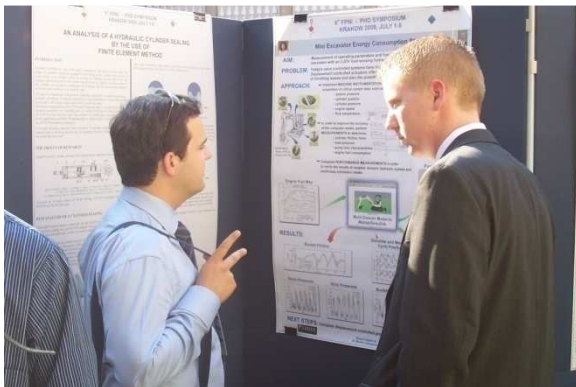

Edward (right) at the poster session



View of Cracow from Wawal Castle Cathedral bell tower



Copernicus studied here



The bike tour through Cracow



(clockwise from front left) Chris, Jonathan, Jonathan (UMN), Kyle, Jen, and Andrew enjoying some beverages in the town square



The Maha team with Dr. Wolfgang Backé outside Cracow University of Technology, Institute of Machine Design

*(back row left to right) Andrew, Edward, Daniel, Matteo, Kyle, Chris, Josh and Rajneesh
(front row left to right) Najoua, Rick, Ganesh, Jonathan, Dr. Wolfgang Backé, Monika*

Bath ASME Symposium on Fluid Power and Motion Control. Bath, England. September 10 – 12, 2008.

Attendees: Monika Ivantysynova
Chris Williamson (Presenter)

7th JFPS International Symposium on Fluid Power. Toyama, Japan. September 15 – 18, 2008.

Attendees: Monika Ivantysynova (Invited Lecture)
Chris Williamson (Poster Presentation)



Monika during her invited lecture presentation



Chris standing by his poster at JFPS



Monika and other attendees at JFPS

SAE. Rosemont, Illinois. October 8, 2008.

Attendees: Monika Ivantysynova
Rajneesh Kumar
Kyle Williams

ERC – NSF Annual Meeting of Executives. Washington, DC. December 3 – 5, 2008.

Attendees: Monika Ivantysynova

10 Awards and Honors

Backé Medal for Best Paper

Presented to Jonathan Baker by Dr. Wolfgang Backé at the 5th Fluid Power Net International PhD Symposium held in Cracow, Poland, for his paper *Investigation of Power Losses in the Lubricating Gap between the Cylinder Block and Valve Plate of Axial Piston Machines*.



Photos courtesy of 5th FPNI PhD Symposium

Two other Maha team members, Najoua Jouini and Richard Klop, were recognized with Honorable Mention for their papers *Valve Plate Surface Temperature Prediction in Axial Piston Machines* and *Investigation of Noise Source Reduction Strategies in Hydrostatic Transmissions* respectively.



Najoua



Rick

11 Maha in the News

Research at the Maha Fluid Power Research Center has generated quite a lot of public interest. A selection of these articles have been included after the following list of references.

- Boulden, Larry. "Energy-sipping Hydraulics", *Design World*, January 2008.

- Venere, E. Fuel-saving designs improve efficiency of hydraulic systems. *Purdue University News*, September 9, 2008,
<<http://news.uns.purdue.edu/x/2008b/080909IvantysynovaPumps.html>>

- Fuel-saving designs improve efficiency of hydraulic systems. *ScienceDaily*, September 22, 2008,< <http://www.sciencedaily.com/releases/2008/09/080909205549.htm> >.

- Williamson, Christopher, and Coblitz, Kristine (ed.). "CCEFP Research Focus, Project 1A.2: Optimal Power Management for Mobile Fluid Power Machines Using Displacement-Controlled Actuators", *Fluid Power Journal*, September/October 2008.

- Canter, Neil. "Improving efficiency of mobile hydraulic systems", *Tribology & Lubrication Technology*, October 2008.

- Presher, Allen. "Pump-Controlled Hydraulics", *Design News*, October 2008.

- EauClaire, Michelle. "Efficient, effective, compact", *OEM Off-Highway*, February 2009.

RELATED INFO



September 9, 2008

* [Monika Ivantysynova](#)

* [Maha Fluid Power Research Center](#)

Fuel-saving designs improve efficiency of hydraulic systems

WEST LAFAYETTE, Ind. - Researchers at Purdue University have shown how to reduce fuel consumption and dramatically improve the efficiency of hydraulic pumps and motors in heavy construction equipment.



The new designs incorporate two innovations: They eliminate valves now needed to direct the flow of hydraulic fluid in heavy equipment, and they also might incorporate textured "microstructured" surfaces inside pumps to improve performance.

Research has shown the "valveless" design alone could reduce fuel consumption by 40 percent. Further savings could be realized by combining the valveless design with the advanced microstructured surface concept, said Monika Ivantysynova, Maha Fluid Power Systems Professor in Purdue's School of Mechanical Engineering.

Hydraulic pump efficiency
[Download photo](#)
caption below

The microstructured surfaces have been shown to dramatically reduce power losses due to friction caused by hydraulic fluid, said Ivantysynova, director of Purdue's Maha Fluid Power Research Center.

Findings were detailed in several technical papers presented by her research group earlier this summer at the Fifth Fluid Power Net International Ph.D. Symposium in Krakow, Poland.

"Currently, the best pumps and motors may have a top efficiency of 92 percent, but this efficiency level is only in a certain range of operation," Ivantysynova said. "These hydraulic pumps don't always run at this maximum level. Sometimes you only need them to provide a small amount of pressure or flow, for example, to simply hold a tool in place. Then you aren't running the pump under its highest loads, and the efficiency goes way down."

Findings have shown the microstructured surfaces reduce losses due to friction by up to 57 percent when the pump is operating at low levels and about 10 percent when operating under heavy loads. One of the research papers about the microstructured surfaces was cited as a "best paper" during the conference and was written by graduate student Jonathan Baker and Ivantysynova.

Engineers in the center are working on ways to design pumps and motors that are more efficient in their entire range of operation.

Hydraulic systems use a central "variable displacement pump" that pressurizes fluid, and valves direct the flow of fluid to "actuators," which move tools such as shovels and buckets in excavation equipment. In the new valveless design, each actuator has its own pump, eliminating the need for valves.

An excavator has been equipped with the new valveless technology in the Purdue center.

These microstructured surfaces are located in narrow gaps at several locations inside a pump that are filled with hydraulic fluid. The fluid-filled gaps, which both seal the high-pressure chamber and also work as a bearing that allows parts to move freely, are a major source of power losses.

"We are working on those gaps by using computer simulations to understand all the physical effects and to reduce efficiency losses due to friction caused by the viscosity of hydraulic fluid," she said. "We know our simulations are very close to the real physics, and we are currently working to manufacture the surfaces and will do measurements."

Conventional wisdom states that the surfaces should be polished smooth, but Ivantysynova discovered that having a surface containing features one micron high improves efficiency. The gaps are located between the pump's piston and cylinder walls and between the cylinder block and a part called the valve plate, which connects to the cylinder along with the pump ports.

Ivantysynova made the microstructured surface discovery while studying the effects of improperly machined surfaces.

"We learned that it actually improved performance to have surfaces that were not completely smooth, which was unexpected," she said.

Purdue has filed a patent for the innovation, called an "advanced gap surface design."

The innovations might be applied to a new "hydraulic hybrid" concept for cars that would use a hydraulic motor to save energy in hybrid cars.

While hydraulic pumps work by compressing a fluid, which is then used to drive tools, hydraulic motors operate in the reverse manner: high-pressure fluid is pushed into a chamber, which is used to drive a shaft and provide torque.

The hydraulic hybrids would store energy while a car is braking by compressing hydraulic fluid in a tanklike "accumulator." Then the high-pressure fluid in the accumulator would be used to drive a hydraulic motor, providing torque to the wheels and saving fuel.

In conventional electric hybrids, energy is stored by charging a battery while the car is braking.

"With batteries, however, only a portion of the braking energy can be stored because it takes much longer to charge the battery than it does to charge the accumulator with high-pressure hydraulic fluid," she said.

Engineers in the center are building a test rig of the hydraulic hybrid design, and Purdue has filed a patent on the concept.

The Maha Fluid Power Research Center is part of the Engineering Research Center for Compact and Efficient Fluid Power, funded by the National Science Foundation, participating companies and universities.

Writer: Emil Venere, (765) 494-4709, venere@purdue.edu

Source: Monika Ivantysynova: 765 49-66578, mivantys@purdue.edu

Purdue News Service: (765) 494-2096; purduenews@purdue.edu

Note to Journalists: An electronic copy of this research paper is available from Emil Venere, (765) 494-4709, venere@purdue.edu. Ivantysynova is pronounced Eye-Van-Tiss-In-Ova.

PHOTO CAPTION:

Monika Ivantysynova (center), the Purdue Maha Professor of Fluid Power Systems, works in her lab with Edat Kaya (left), a lab engineer, and Donnell Cunningham, a student from the Summer Undergraduate Research Program. Ivantysynova, director of the university's MAHA Fluid Power Research Center, has shown how to dramatically improve the efficiency of hydraulic pumps and motors in heavy construction equipment and reduce the machinery's fuel consumption. (Purdue University photo/Vincent Walter)

A publication-quality photo is available at <http://news.uns.purdue.edu/images/+2008/ivantysynova-pump.jpg>

ABSTRACT

Investigation of Power Losses in the Lubricating Gap Between the Cylinder Block and Valve Plate of Axial Piston Machines

Jonathan Baker¹ and Monika Ivantysynova² - Department of Mechanical Engineering MAHA Fluid Power Research and Education Center

The lubricating gaps are the primary source of energy dissipation in piston machines. The paper presents results of a simulation study that investigates the effect that microsurface shape variations on the cylinder block gap surface have on power loss in the cylinder block valve plate interface. As the gap height of the lubricating film represents the most critical parameter relating to pump performance, special attention is given to the relation between gap height, operating parameters, surface design and power loss. A special in-house code has been used for this research study. The simulation model covers fluid structure interaction and micro motion of the cylinder block resulting from oscillating piston forces. Details of the model are explained. The model allows for analysis of the pressure and velocity fields generated in the lubricating film and calculates leakage, viscous friction and energy dissipation. Finally, simulation results obtained from a complete pump model considering all three gaps of a swash plate axial piston pump are compared with measurement data.

To the [News Service](#) home page



Research Focus

Project 1 A.2: "Optimal Power Management for Mobile Fluid Power Machines Using Displacement-Controlled Actuators"



An excavator in action

Project Summary: Large machines like excavators run on diesel fuel. Today's machines burn much more fuel than they need to, which costs a lot of money and hurts the environment. The project will create new hydraulic systems and computerized controls for construction machinery that work better and use less fuel.

What is the overall goal of this project?

We are all painfully aware of rising fuel prices. With diesel near \$5.00 a gallon, we need new solutions for improving the efficiency of mobile hydraulic machinery. Our project focuses on machines with multiple actuators that work simultaneously—excavators, telehandlers, timber harvesters, and so on. The main source of power loss on these machines is the flow control valves. Even load-sensing systems have high throttling losses when multiple cylinders and motors operate at different pressure levels. Our mini-excavator simulations are showing that more than 40% of the total engine energy is wasted in valve losses during a typical trench-digging cycle. The solution we propose is **displacement-controlled actuation**, using variable displacement pumps to control the cylinders directly. This eliminates the power losses inherent to valves and allows energy recovery as the pumps can run in motoring mode.

How did this particular project come about?

This is a topic that Prof. Monika Ivantysynova has been studying for nearly 10 years, first in Germany and now in Indiana at Purdue University. Our original research was with wheel loaders. Now with support of the CCEFP, we're developing a 5-ton excavator with all functions under displacement control.

What direct application will this project have in the fluid power industry?

This is definitely an applied project. We hope that the fluid power industry will take the circuits and controls that we develop and put them into production. Of course there are obstacles: the current cost and availability of necessary components, packaging constraints, competition from other alternative technologies, and the tremendous inertia of the status quo. When I present at conferences, the response from industry is often "That's a great idea, but pumps are just too expensive. It won't be commercially viable." Our answer is that bringing displacement-controlled actuation to market would generate enough volume to drive the price down considerably. Add the value of advanced controls to much higher fuel efficiency, and this could be a competitive solution.

What work has been done so far and what have been the results?

In simulation, we're seeing 30-45% savings in total energy. Our next step is building a prototype and verifying these results experimentally. We're working on this right now.

Looking ahead, what is planned for this project in the future and what is the time frame?

Pump-controlled hydraulics is really just the tip of the iceberg. Lower power loss is an important contribution, but perhaps just as important is the transition toward electrohydraulic control and hybrid systems. With displacement control, we can actively control engine speed and pump displacement to keep the system operating at optimal efficiency for additional fuel savings. Add position sensors, and we can make the machine easier to operate and more productive with cylinder coordination, automated functions, manipulator motion optimization...The sky's the limit.

What is your role in the project? How and why did you get involved?

I'm responsible for developing the excavator controls. My PhD topic is power optimization with displacement-controlled actuators, including optimizing the operation of the engine, hydraulic components and manipulator trajectory. I joined the project because it looked like a great opportunity for interesting work and a marketable education. And if I can do a

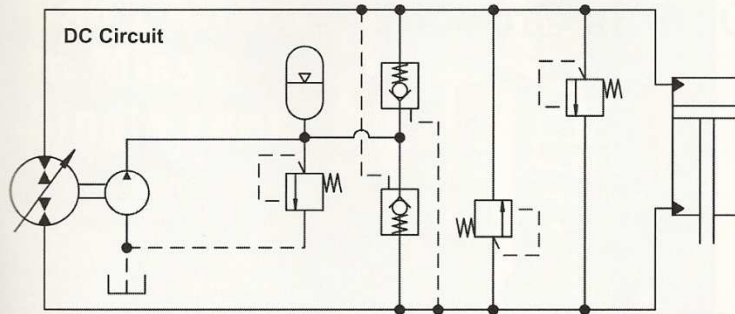

little bit to help the economy and the environment, that's a bonus.

What has the experience of working on this project been like for you? What have you learned by being a part of it?

What I like most about this project is its practical relevance. Much of the academic research that goes on is very theoretical. Some poor graduate students spend several years of their lives probing the depths of an obscure topic and writing a thick dissertation that ends up on a dusty shelf in the back of the university library. I appreciate the fact that what I am learning about designing, modeling and controlling fluid power systems is not only interesting to me, but it is also in demand.

Why do you feel the CCEFP is important?

I remember a conversation I had with another mechanical engineering grad student. When I told her about my research, her response was "Isn't hydraulics a mature field?" as though there was nothing left to study. Maybe this is a common perception. There

hasn't been much academic research in fluid power in the United States in the past 30 years, even though this research has continued in Europe and Japan. All of this is changing with the CCEFP. The number of professors, graduate students and research projects in hydraulic and pneumatic technology is on the rise. If these projects are successful, there will be tremendous improvements in components, systems and fluids. And even if not, a new generation of engineers and scientists with fluid power training will revitalize academic and industrial research in this country for years to come.

To answer her question, yes, fluid power technology is mature. Just like turbomachinery and internal combustion engines. And like these other fields, recent advances in materials, electronic controls and computational analysis methods combined with new demands for energy and environmental conservation are spurring ongoing fluid power research. There is still plenty of work to do, and with the CCEFP, there are now more resources to do it.

Additional Information:

Maha Lab website: <http://pasture.ecn.purdue.edu/~mahalab>

Chris Williamson earned his undergraduate bachelor of science degree in mechanical engineering from Brigham Young University. He has completed his masters degree and is currently pursuing his PhD from Purdue University in Agricultural and Biological Engineering at Purdue. Chris has industrial research and development in his bright future! His work takes mobile hydraulic machines and adds electrohydraulic pump control systems. This saves fuel and allows computerized machine control for better performance and productivity. His control systems will be implemented on the excavator test bed, and hopefully some of his contributions will find their way into commercial application. The result would be a new generation of construction and agricultural equipment that are easier and more comfortable to operate and are significantly more efficient. Also, Chris has recently been elected to serve as the SLC's new Vice President. He can be reached at williaca@purdue.edu.



Summer 2008 Group Photo

www.ifps.org | www.fluidpowerjournal.com

September/October 2008 | 53

TECH BEAT

Dr. Neil Canter / Contributing Editor

Improving efficiency of mobile hydraulic systems

New technology is improving energy efficiency in mobile hydraulic fluids with the use of displacement-controlled actuators.

KEY CONCEPTS:

- Current load-sensing mobile hydraulic systems are inefficient because they are controlled with valves that restrict fluid flow.
- Improved efficiency could be realized through the use of displacement-controlled actuators.
- A simulation study using a Bobcat 435 compact excavator shows that a DC hydraulic system could produce an energy savings of 39% over a LS hydraulic system.

Increases in energy costs are prompting the hydraulic industry to pursue improvements in the energy efficiency of mobile machines. A key example is an excavator that is designed for digging dirt in construction, mining and other applications.

In an excavator, the operator is located in a cabin that can swivel in a 360-degree fashion. The cabin is placed on tracks that can propel the vehicle over virtually any kind of terrain. Three hydraulic actuators (cylinders) control the movement of a toothed bucket to lift, dig, push and generally move material. A typical compact excavator is shown in Figure 1.

Chris Williamson, a doctorate student in the department of agricultural and biological engineering at Purdue University, says, "The trouble with mobile hydraulic systems is that they are controlled with valves. Valves act as fluid resistances, adapting the supply pressure to the load pressure by restricting the flow and converting fluid power to heat. These 'throttling losses' are the greatest contributor to system inefficiency for a multiactuator system in an excavator or similar machine.

"The most common hydraulic circuit design in mobile equipment today is a load-sensing (LS) system. In this configuration, a single hydraulic pump supplies fluid to several actuators. The pump is constantly adjusted to the highest pressure required by any of the actuators. Once an actuator needs higher pressure, it provides feedback through a hydraulic line to the pump to increase pump power. Unfortunately, the pump pressure must be reduced by a valve to the lower pressure level required by the other actuators. Essentially, there is a mismatch between power supply and power consumption, and the difference is wasted."

Once an actuator needs higher pressure, it provides feedback through a hydraulic line to the pump to increase pump power.

To explain, Williamson makes an analogy to electrical technology. "Years ago, variable speed electric motors operated with direct current and were controlled with resistors. Now variable speed motors are usually frequency controlled with alternating current. It's an inherently more efficient approach. Hydraulic systems are still controlled with resistances, and we're now at a point where we need more

The biggest challenge in using DC hydraulics is not the added weight of additional pumps but space and cost.

efficient flow-control technologies.”

An alternative mobile hydraulic system that could offer improved efficiency utilizes displacement-controlled (DC) actuators. Williamson explains, “DC actuation involves the direct control of an individual actuator with a single hydraulic pump. Through this technology, the hydraulic pump can consistently provide the actuator with the optimal amount of fluid power needed. Valves are no longer used to control the actuator power.”

The prospect of realizing efficiency improvement in mobile hydraulic fluids with DC actuators has not been determined until now.

DISPLACEMENT-CONTROLLED ACTUATORS

Previous work by the researchers on wheel loaders and skid-steer loaders showed that DC hydraulic systems display fuel savings between 10% and 20% compared to existing systems. In current work, DC and LS hydraulic systems are compared by mathematical modeling in a simulation study using a Bobcat 435 compact excavator (Figure 1).

Williamson says, “We chose a five-ton miniexcavator because it has the same load-sensing hydraulics found in larger excavators, but it is small enough to be evaluated in the laboratory.” Smaller excavators are more versatile than the larger machines used for mining and heavy construction, as they have additional actuator functions and can be operated with other attachments besides a bucket for digging.

The simulation study measured dynamic and steady-state processes that each hydraulic system would use in controlling the excavator. An example of the former is how the excavator responds to an applied force. In the latter, how efficiently the hydraulic systems are using energy is evaluated. Steady-state characteristics were based on experimental measurements of the hydraulic components.

The energy consumed by the excavator in a 60-second digging cycle was measured using both hydraulic systems. Five power distributed categories were evaluated including actuator work, valve losses, pump losses, frictional losses (in the hoses and actuator seals) and other losses for charge and drive pumps and a cooling fan. Williamson says, “We found that the largest difference in energy loss was due to the hydraulic valves. In fact, for the LS hydraulic system, valve

losses represent 43% of the total energy consumed.”

In contrast, the DC hydraulic system does not rely on valves for actuator control, which means there is minimal energy loss. Overall, if DC technology is used, the excavator would realize an energy savings of 39%.

The biggest challenge in using DC hydraulics is not the added weight of additional pumps but space and cost. Wil-

liamson says, “The additional pumps weigh a few hundred pounds, which is negligible when the excavator weighs five tons. But finding a way to fit more pumps in an already compact machine was not a trivial problem. Also, equipment manufacturers like Bobcat are very sensitive to cost increases. Our argument is that customers are willing to pay a little more up front for much lower operating costs. It’s the same phenomenon that we see with hybrid passenger cars.”

This simulation work was carried out with an ISO VG46, mineral oil-based hydraulic fluid. Williamson believes there is a need to evaluate other fluids in order to determine if more energy savings can be realized. He says, “More pumps in a DC hydraulic system means their characteristics and performance are

a dominant factor. Any lubricant that can help to improve lubrication and pump performance would increase energy efficiency.”

Future work will involve the actual installation of a DC hydraulic system in a prototype excavator. Once the machine is complete, system performance will be further improved with new control algorithms for optimizing the operation of the diesel engine and hydraulic system.

Additional information can be obtained from a presentation made by Williamson at a recent conference.¹ He can also be contacted at willia ca@purdue.edu. The research is funded by the Center for Compact and Efficient Fluid Power (CCEFP) and the National Fluid Power Association (NFPA).

REFERENCE

1. Williamson, C., Zimmerman, J., and Ivantysynova, M. (2008), “Efficiency Study of An Excavator Hydraulic System Based on Displacement-Controlled Actuators,” Presented at the Bath/ASME Symposium on Fluid Power and Motion Control, Bath, U.K., September 2008.



Figure 1

A Bobcat 435 excavator was used to simulate a study showing that displacement-controlled (DC) actuators can improve the efficiency of a mobile hydraulic system. [Courtesy of Purdue University]

12 Educational Activities

Dr. Ivantysynova has taught, developed or been advisor too several courses in her time thus far at Purdue:

- ABE 691 / ME 697 – Hydraulic Power Trains and Hybrid Systems (*Spring 2008*)
- ME 597/ABE 591 – Design and Modeling of Fluid Power Systems (*Fall 2005, 2006, 2007 and 2008*)
- ME 463 – Senior Design Project (*Spring 2006, 2007 and 2008*)

ME 597 /ABE 591 – Design and Modeling of Fluid Power Systems Fall Semester 2008

2008 marked the fourth consecutive year of ME 597/ABE 591 being offered.

Course Description:

ME 597/ABE 591 Design and Modeling of Fluid Power Systems

1 Semester, 3 Lecture/week, 3 Credits

Prerequisite: ABE 435 or ME 309, ME 375 or consent of instructor.

This course provides an introduction into modeling and design of fluid power components and systems. Modeling techniques based on physical laws and measured performance characteristics will be applied to design and analyze component and system performance. Fundamentals: design principles of displacement machines, flow and pressure control, motion control using resistance control, motion control using displacement controlled actuators, variable speed transmissions, modeling of flow in lubricating gaps, transmission line models, secondary controlled systems, load sensing systems.

Textbook: Course Notes

References:

J. Ivantysyn and M. Ivantysynova: *Hydrostatic Pumps and Motors Principles, Design, Performance, Modelling, Analysis, Control and Testing*. Akademia Books International, New Dehli, 2001.

Fitch, E.C. and I.T. Hong: *Hydraulic Component Design and Selection*. BarDyne, Inc. 1998.

H. E. Merritt. *Hydraulic Control Systems*. John Wiley & Sons, Inc.

Coordinator: M. Ivantysynova, Maha Professor of Fluid Power Systems, ME and ABE

Goals:

To give seniors and graduates students in engineering the ability to design and analyze fluid power systems applying computational methods. The course is designed to teach students how to apply engineering fundamentals to develop mathematical models of fluid power components and systems, so that advanced systems can be developed.

Prerequisites by Topic:

Fluid Mechanics

Modeling and analysis of physical systems

Differential equations and calculus

Topics:

1. Introduction and overview of components, circuit and system design methods
2. Fluid properties, modeling of transmission lines, impedance model of lines
3. Displacement machines design principles
4. Steady state characteristics, measurement methods and modeling
5. Gap flow models
6. Flow and pressure pulsation
7. Resistance control, modeling of steady state and dynamic performance
8. Pressure and flow control valves
9. Servo and proportional valves, nonlinear and linear system models
10. Modeling of valve controlled systems, linear and rotary actuators
11. Modeling of displacement controlled actuators, pump control systems
12. Secondary controlled actuator, modeling and application
13. Special system design aspects, load sensing systems

Computer Usage:

Required in solution of homework problems and final design project. Matlab experience would be helpful but not necessary.

Laboratory Project:

Hardware-in-the-loop test rig of a vehicle drive line

Aim:

To learn to plan, design and operate an experimental test set up for performance testing of a fluid power system. To become familiar with X-PC target software, measurement equipment and data acquisition system used on a hardware in-the-loop test rig of a vehicle drive line. The project should also prove the student's ability to perform a measurement, evaluate test data and write a measurement report in an appropriate form.

Method:

Students will have to form teams of three students. One lecture will be used for introduction into the problem and the existing test rig. Students will then have to learn to operate the test rig and to perform measurement. Each team has to write a measurement report.

Formulation of problem:

Students are requested to perform the following work:

1. Study the test rig structure including the X-PC target system and describe it in the report accordingly.
2. Specify a drive cycle of the vehicle you like to test using the hardware-in-the loop test environment.

3. Perform the measurement of the drive cycle! Assistance will be given. Each group needs to make arrangements for performing their tests in the lab with Edat Kaya.
4. Evaluate the test results and complete a report.

Nature of the Design Content:

The design component of this course will consist of students designing a fluid power system to meet a particular need and required performance. The students will solve several sub problems of an entire system design as part of the regular course homework.

Engineering project to be completed during the course**Aim:**

To demonstrate in form of an engineering project the ability to design fluid power systems, to understand the function of components and how to model their steady state and dynamic behavior to predict the system performance. The project should also prove the student's ability to write an engineering report in an appropriate form.

Method:

Students will solve several sub problems of the entire system design work as part of the regular course homework.

Formulation of problem:

Students are requested to perform the following work:

1. Choose and define your own system design project, i.e. define a hydraulic actuator, drive system or transmission as a part of a machine or vehicle. Describe briefly the machine or vehicle function.
2. Specify the system requirements (work task, operating parameter range, safety issue, energy consumption, type of primary energy source) and conclude the requirements in form of a system specification as the first chapter of your project report.
3. Remember to apply individual course topics to your system
4. During the semester it will be requested that you add a second actuation system to your initial one. This is to ensure that each project has at a minimum one rotary and one linear drive system.
5. It is also necessary that you investigate and compare at least one alternative solution for one of your chosen actuator/drive or transmission solution. The comparison must include energy consumption and a brief statement of other properties (system complexity, costs etc).
6. Define system structure, draw circuit diagram and a scheme showing the interfaces between your fluid power system and the entire machine/vehicle.
7. Select type and size of components
8. Create models to describe the loss behavior, energy consumption
9. Create models to predict system behavior including dynamics (system parameter as function of time)
10. Define measurement methods and test procedure for a selected component and your whole actuation system
11. Write the system development report

ABET category content as estimated by faculty member who prepared the course description:
 Engineering Science: 1.5 credits or 50%
 Engineering Design: 1.5 credits or 50 %





Grading: 60% engineering project, 30 % written final exam, 10 % measurement report

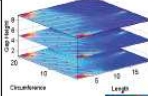

Design and Modeling of Fluid Power Systems ME 597 / ABE 591

Fall Semester 2008



This course provides an introduction into modeling and design of fluid power components and systems. Modeling techniques based on physical laws and measured performance characteristics will be applied to design and analyze component and system performance. Fundamentals: design principles of displacement machines, flow and pressure control, motion control using resistance control, motion control using displacement controlled actuators, variable speed transmissions, modeling of flow in lubricating gaps, transmission line models, secondary controlled systems, load sensing systems.

▪ **Valve controlled systems**

To learn how to model fluid power components and systems based on physical laws and when to use these models.

- Modeling and design of linear actuators
- Dynamic performance
- Design example

▪ **Displacement Machines**

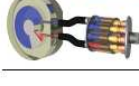
- Design principles
- Steady state characteristics, measurement and modeling
- Gap flow models
- Flow and pressure pulsation
- Instantaneous cylinder pressure



▪ **Displacement controlled systems**

To learn how to design advanced energy saving hydraulic actuators and transmissions and to predict their performance.

- Pump control system design
- Design of hydrostatic transmissions
- Secondary controlled actuators
- Pump controlled linear actuator

▪ **System design - special topics**

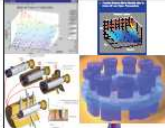
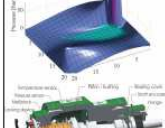
- Power supply systems
- Load sensing
- Energy aspects

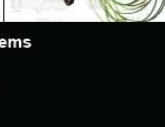
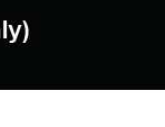
▪ **Resistance Control**

To learn to design fluid power systems and to understand the function of components and how to model their steady state and dynamic behavior. To determine steady state and dynamic characteristics of fluid power components and systems based on measurements

- Pressure and flow control
- Servo- and proportional valves
- Nonlinear and linear system models

by Monika Ivantysynova, MAHA Professor Fluid Power Systems

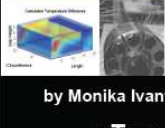
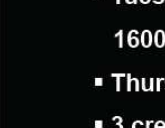
- Tuesday 8:00 - 11:00 @ MAHA LAB, 1600 Kepner Drive, Lafayette
- Thursday 1:00 – 2:45 (lab 2 times only)
- 3 credits

ABE 691 / ME 697 – Hydraulic Power Trains and Hybrid Systems Spring Semester 2008

In 2008 a new 600 level course ABE 691M / ME 697M – Hydraulic Power Trains and Hybrid Systems has been developed. The was offered for the first time this past Spring.

Course Description:

ME 697M/ABE 691M Hydraulic Power Trains and Hybrid Systems

1 Semester, 2 Lecture/2 Lab/week, 3 Credits

Prerequisites: ME 475, 575 or ABE 460, ABE 591/ME 597 or ABE 435 or consent of instructor.

The course provides a thorough understanding of continuously variable transmissions and hydraulic hybrid power train systems. It covers the design and modelling techniques for analyzing, predicting, and specifying the performance of continuously variable transmissions, hybrid power trains and complex hydraulic machine systems including transmission and power train controls.

It also provides an introductory treatment of vehicle steering, braking and active vibration damping systems based on displacement control. Fundamentals of power train control and machine power management concepts are discussed.

Textbook: Course Notes

Coordinator: M. Ivantysynova, Maha Professor of Fluid Power Systems

Lecturers: M. Ivantysynova, R. Klop, K. Williams, R. Kumar, and C. Williamson

Goals:

1. To learn to design, model and analyze continuously variable transmissions (CVT) and hybrid power train systems.
2. To determine steady state and dynamic characteristics of CVT's.
3. To learn how to apply computer software to predict performance of CVT systems and power train structures including controls.
4. To learn how to model and simulate coupled hydraulic-mechanical systems of off-road vehicles and to predict their performance.
5. To become familiar with machine power management strategies for hydraulically powered machinery.

Topics

1. Hydrostatic and Hydrodynamic Transmissions
2. Power Split Transmissions and Hydraulic Hybrid Systems
3. Power Train Control and Machine Power Management
4. System Design – Special Topics

Laboratory Experiments

1. Hydrostatic Transmission Performance Measurements
2. Hardware-in-the Loop Transmission Testing
3. Power Train Control Performance
4. Vehicle Vibration Measurement

Grading: 20 % for each of three design projects and 10 % for each of four measurement reports.



Hydraulic Power Trains and Hybrid Systems
ME 697M / ABE 691M

Spring Semester 2008
This course provides a thorough understanding of continuously variable transmissions and hydraulic hybrid power train systems. It covers the design and modeling techniques for analyzing, predicting, and specifying the performance of continuously variable transmissions, hybrid power trains and complex hydraulic machine systems including transmission and power train controls. It also provides an introductory treatment of vehicle steering, braking and active vibration damping systems based on displacement control. Fundamentals of power train control and machine power management concepts will be discussed.

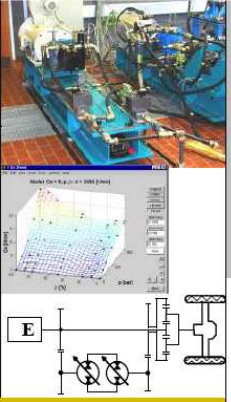

▪ **Power train control and machine power management**

- Transmission & engine control
- Power train control using efficiency maps of power train components
- Machine power management

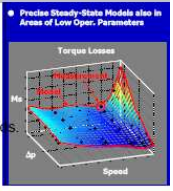

▪ **System design - special topics**

To learn how to design advanced energy saving hydraulic circuits for power trains and hydraulic hybrids.

- Hydraulic steering, braking systems
- Active vibration damping
- Transmission noise

▪ **Hydrostatic & hydrodynamic transmissions**

- Design principles of CVT
- Steady state characteristics,
- Measurement and modeling
- Secondary controlled 4 wheel drive
- Torque converter

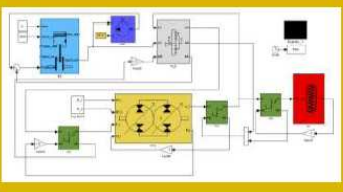

▪ **Power split transmissions & hydraulic hybrid systems**

- Output coupled transmissions
- Input coupled transmissions
- Dual stage and compound systems
- Nonlinear and linear system models
- Hydraulic hybrid power trains



▪ **Laboratory Experiments**

- CVT performance measurements
- Hardware-in-the loop testing
- Vehicle vibration measurements



▪ by **Monika Ivantysynova, MAHA Professor Fluid Power Systems**

▪ **Tuesday 8:30 - 10:20**

▪ **Thursday 8:30 - 10:20 @ MAHA Lab**

ME 463 – Senior Design Spring Semester 2008

For the past few years, a team of undergraduate students have worked on the Maha Fluid Power Research Center’s hydraulic car that was originally designed and constructed for the DARPA challenge. The vehicle has progressed through several stages of development. This past spring, a team of undergraduates successfully integrated a remote control communication system that allowed them to move the car forwards and backwards. Dr. Ivantysynova, along with Dr. Peter Meckl of Mechanical Engineering and Barrett Robinson of Electrical and Computer Engineering, advised the group of students.



The hydraulic car



Manning the controls

13 Maha Social Events

The Maha team isn't always working. Occasionally we get out and have some fun together. Below are some highlights of Maha social events this past year.

Kyle's Birthday Celebration



(from left front moving back) Chris, Edward, Monika, Rohit, Ganesh, Matteo, Najoua, Rick
(from right front moving back) Josh, Shekar, Jonathan, Donatien, Jim, Taka, Jeff, Andrew



Yummy birthday cake...

Bowling



Jeff



The Mahites look on

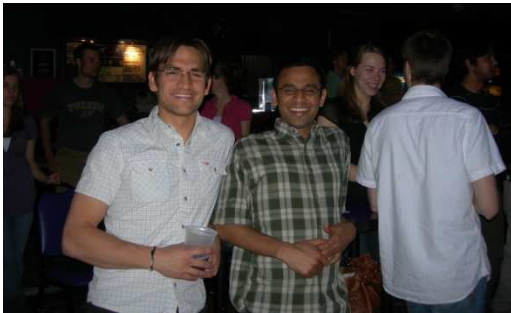

Rick and Ganesh



Andrew and Rohit



Edward and Sarah



Kyle going for a strike



Matteo gives it a go



Jeff, Jonathan, Daniel and Monika

Annual Summer Party at Monika's House



Kyle and Edward



Katie, Roman, the Zimmermans, Whiskey and Ruby



The Maha crew and their families

14 International Journal of Fluid Power

I am proud to report that the *International Journal of Fluid Power* is ready to move into its 10th year of publication. The third issue of the ninth volume was printed and sent to our readers this past November. This third issue was dedicated to the memory of our good friend Bob E. Koski, one of the strongest supporters of Fluid Power Net International and the *Journal*, who passed away this year. Also the March issue was printed as special issue and dedicated to the memory of our colleague Serge Scavarda. Serge had served as outstanding reviewer and member of the Editorial Board of the *Journal* since 2000. As the field of fluid power continues to grow, Bob and Serge will forever be remembered as great colleagues, innovative leaders and teachers in their field and as men of tremendous warmth and charity.

I would like to express my thanks to you all for your continuous support of the *Journal*, especially for reviewing papers and submitting manuscripts. I would also like to thank all Associate Editors for their great help and advice. The list of reviewers will be published again in the first issue of 2009

The *Journal* has been online since March 2006. The online access has strengthened the Journal's position and definitely will continue to contribute to the increase in the number of citations. The Journal's website has been moved to a TuTech server. With this transaction the web address had to be changed. The new web address is <http://journal.fluid-power.net>. We have very successfully continued our co-operation with the Japan Fluid Power System Society "*Fluid Power System*", the Italian "*Oleodinamica Pneumatica Lubrificazione*" and the German "*Ölhydraulik und Pneumatik O+P*". All three agreements allow publishing of translated papers in these partner journals after publication in the *International Journal of Fluid Power*.

After failing our re-evaluation of the *Journal* by the Scientific Citation index in 2006 we will be allowed to request a re-evaluation in 2009. As this is one of the most important goals of the *Journal* I would like to encourage your help increasing the number of citations by referring your publications as well as the publications of others in the *International Journal of Fluid Power* more often.

Currently the Journal is indexed by Cambridge Scientific Abstracts, *Elsevier Compendex Engineering Information*, European Environmental Information Database, CEDEFOP Training Village and Fachinformation Technik.

Let me add some statistical information about the Journal's progress. Since the establishment of the *Journal* in 2000 we have presented 26 different fluid power software tools and have introduced 26 fluid power research centres from four different continents. Authors from 32 countries have submitted papers to the *International Journal of Fluid Power* during the last nine years. In 2008, 26 papers were submitted and reviewed. This number remained constant in the last two years however, the number of papers submitted by North American authors continues to grow. 10 out of the 26 submitted papers were from authors from USA and Canada. All papers are peer reviewed by at least two experts. Very often three independent reviewers are involved to

ensure that the review process is fair and that the *Journal's* final publication is of the highest quality. The current rate of successfully approved papers is 46%.

Once again, I would like to thank you all for your continuous support of the Journal. I wish you all the best for 2009.



Monika Ivantysynova
Editor-in-Chief

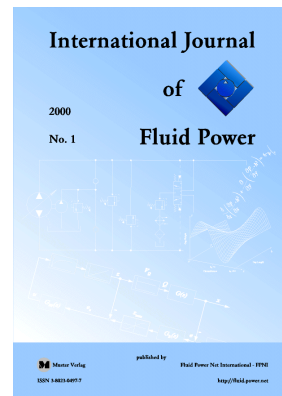

15 Maha Team in 2008



Dr. Monika Iwantysynova,
Maha Professor of Fluid Power Systems

email: mivantys@purdue.edu

Graduate Students

Jonathan Baker
Master's Student
Email: jebaker@purdue.edu
Phone: (765) 448-1456
BS: Davidson College
Origin: USA
June 2006 – present



Jim Bartlett
Master's Student
Email: jcbartle@purdue.edu
Phone: (765) 449-7980
BS: Purdue University
Origin: USA
July 2008 – present



Shekar Degaonkar
Master's Student
Email: cdegaonk@purdue.edu
Phone: (765) 449-7980
BS: Dr. BA Marathwada University, India
Origin: India
July 2006 – present



Andrew Fredrickson
Master's Student
BS: Taylor University
MS: Purdue University
Origin: USA
July 2006 – August 2008



Reece Garrett
Master's Student
Email: ragarret@purdue.edu
Phone: (765) 448-1456
BS: Brigham Young University
Origin: USA
July 2007 – present



Edward Hughes
Master's Student
Email: echughes@purdue.edu
Phone: (765) 449-7980
BS: Purdue University
Origin: USA
July 2007 – present



Richard Klop
PhD Student
Email: rklop@purdue.edu
Phone: (765) 449-7514
BS: Michigan State
MS: Purdue University
Origin: USA
August 2005 – present



Rajneesh Kumar
PhD Student
Email: rajneesh@purdue.edu
Phone: (765) 449-7980
BS: Indian Institute of Technology, Madras, India
MS: Purdue University
Origin: India
July 2006 – present



Rohit Kumar
Master's Student
Email: kumar35@purdue.edu
Phone: (765) 448-1456
BS: Birla Institute of Technology, India
Origin: India
August 2007-present



Shinnok Lee
Master's Student
Email: lee20@purdue.edu
Phone: (765) 449-7980
BS: Purdue University
Origin: South Korea
July 2008 – present



Matteo Pelosi
PhD Student
Email: mpelosi@purdue.edu
Phone: (765) 449-7514
BS, MS: Università Degli Studi di Parma
Origin: Italy
September 2007 – present



Jeff Peters
Master's Student
BS: Purdue University
MS: Purdue University
Origin: USA
July 2006 – September 2008



Ganesh Seeniraj
PhD Student
Email: gseenira@purdue.edu
BS: College of Engineering, Guindy, Anna University, Chennai, India
MS: Kettering University
Origin: India
August 2004 – present



Kyle Williams
PhD Student
Email: krwillia@purdue.edu
Phone: (765) 449-7980
BS: Purdue University
MS: Purdue University
Origin: USA
May 2005 – present



Chris Williamson
PhD Student
Email: williac@purdue.edu
Phone: (765) 449-7980
BS: Brigham Young University
MS: Purdue University
Origin: USA
August 2005 – present



Josh Zimmerman
PhD Student
Email: zimmerjd@purdue.edu
Phone: (765) 449-7980
BS: Brigham Young University
MS: Purdue University
Origin: USA
August 2006 – present



Maha Fluid Power Research Center Staff

Edat Kaya
Maha Fluid Power Research Center Manager
Email: ekaya@purdue.edu
Phone: (765) 448-1587
Dipl.-Eng.: Hamburg University of Applied Science
Origin: Germany
August 2005 – present



Anthony Franklin
Lab Technician
Phone: (765) 448-1587
Electrical, Welding and Machine Repair: UAW, National Training Center
Origin: USA
December 2008 – present



Visiting Researchers/Scholars

Daniel Dyminski
Visiting Researcher
Phone: (765) 448-1456
Cracow Academy of Technology
Origin: Poland
September 2005 – December 2008



Takayoshi Ichiyanagi
Assistant Professor/Visiting Scholar
Email: tichiyan@purdue.edu
National Defense Academy of Japan
Origin: Japan
July 2007 – September 2008



Najoua Jouini
Master's Student
BS: Stuttgart University
MS: Stuttgart University
Origin: Tunisia
September 2007 – September 2008



Donatien Keho
Master's Graduate
Email: kelassemaye@yahoo.fr
MS: Toulouse
Origin: France
February 2008 – September 2008



Marcel Tkocz
Master's Student
Email: mail@tkocz.net
Phone: (765) 448-1456
BS: Technical University Dresden
Origin: Germany
August 2008 – present



Andrea Vacca
Assistant Professor of Industrial Engineering
Email: andrea.vacca@unipr.it
Università Degli Studi di Parma
Origin: Italy
June 2008 – October 2008



Summer 2008 Undergraduates

Nicholas Browdues
Undergraduate: Purdue University
Email: nbrowdue@purdue.edu
Origin: USA
SURF Student



Michael Cross
Undergraduate: Univeristy of Tennessee at Knoxville
Email: mcross55@gmail.com
Origin: USA
SURF Student



William Hinson
Undergraduate: Purdue University
Email: whinson@purdue.edu
Origin: USA
SURF Student



Roman Ivantysyn
Undergraduate: Purdue University
Email: rivanty@purdue.edu
Origin: Germany



Katie Livergood
Undergraduate: Purdue University
Email: klivergo@purdue.edu
Origin: USA



Laura Rodriguez
Undergraduate: Instituto Tecnologico de Ciudad Juarez
Email: lauritarr_85@hotmail.com
Origin: Mexico
SURF Student



Ivan Swandono
Undergraduate: Purdue University
Email: iswandon@purdue.edu
Origin: Indonesia
SURF Student



Sihle Wilson
Undergraduate: Florida A&M University
Email: sihle.wilson@ieee.org
Origin: Trinidad and Tabago
SURF Student



16 Visitors & Guests

Nazar Al-Khayat – Director Hybrid Power System Integration, Cummins
Andrea Balluchi – DANA Corporation
Mike Betz – Sauer-Danfoss
Eric Bretey – Sauer-Danfoss
Blake Carl – Parker Hannifin Corporation
Rollen Christianson – Parker Hannifin Corporation
Ray Collett – Parker Hannifin Corporation
Ettore Cosoli – DANA Corporation
Professor Jane Davidson – Professor of Mechanical Engineering, University of Minnesota
Jeff Dowell – Director, Advanced Technology & Systems Group, AM General
Wayne Eckerle – VP Corporate Research & Technology, Cummins
Michael Follis – Sr. Materials Product Engineer, American Axle and Manufacturing
Federica Franzoni – University of Modena, Italy
Luca Gilardino – DANA Corporation
Taylor Holland – Manager, Advanced R&D (General Engine Products), AM General
Ed Ivey – Chief Engineer, AM General
Lew Kaspar – Parker Hannifin Corporation
General Paul Kern – CEO, AM General
Rich Kimpel – Parker Hannifin Corporation
Joe Kovach – Parker Hannifin Corporation
Doug Krantz – Parker Hannifin Corporation
Kevin Landhuis – Sauer-Danfoss
Brewce Larkin – Parker Hannifin Corporation
Mark Lundy – Sr. Product Engineer, American Axle and Manufacturing
Lori Martinelli – Parker Hannifin Corporation
Professor Massimo Milani – University of Modena, Italy
Greg Maxwell – CTO, Parker Hannifin Corporation
Luca Montorsi – University of Modena, Italy
Winston Platt – Chief Engineer, American Axle and Manufacturing
Brent Rajaniemi – Engineer, Advanced IR&D (HRU Tech Resources), AM General
Robert Rhamfeld – Sauer-Danfoss
Daryl Rober – Sauer-Danfoss
Tom Sagaser – Bobcat
Scott Schuh – Bobcat
Matt Simon – Parker Hannifin Corporation
John Sofia – Vice President, American Axle and Manufacturing
John Wall – CTO, Cummins
Daniel Whitman – Parker Hannifin Corporation
Mark Wilson – Chief Engineer, Cummins
Howard Zhang – Parker Hannifin Corporation

In addition to the aforementioned guests, along with Professor Doug Adams and the Purdue Center for Systems Integrity (PCSI), the Maha Fluid Power Research Center was honored to host the Mayor of Indianapolis, Gregory Ballard, along with his wife Winnie on July 29, 2008. The Maha Fluid Power Research Center and PCSI were also proud to host the Purdue University Mechanical Engineering Industrial Advisory Board meeting on September 19, 2008 as well as the Purdue University Herrick Lab Industrial Advisory Board meeting on October 30, 2008.



The Maha Team, Summer 2008