

Batteries Unit Pre-assessment

Name: _____

1. Please draw 2 batteries in series.
2. Please draw 2 batteries in parallel.
3. What is voltage?
4. What is current?
5. How do you position 2 batteries so that their voltages add (series or parallel)?
6. Assume each battery is 6v. What would the measured voltage be in series and in parallel?
Series voltage:
Parallel voltage:
7. Assume each battery is 6v. What would the measured voltage be in series and in parallel?
Series voltage:
Parallel voltage:
8. Do electrons flow from positive to negative or negative to positive?

Batteries Unit

The electrolyte (usually a liquid or paste) in the battery removes electrons from both electrodes (usually a metal). They are designed so that one electrode gives more electrons than the other and so has a lot of electrons near it which gives it a negative charge. That electrode is usually called the cathode. The other electrode also loses electrons and becomes positive but it wants those electrons more than the cathode; that electrode is called the anode. In a battery, the electrons flow from the cathode to the anode.

A chemical reaction is what causes the electrons to be removed from their metals. Energy must be added to remove the electron so that it can escape the base metal. This causes the electron to have more energy than its restful state. This added energy is what causes a battery to have a voltage. Once the chemical reaction stops and all of the electrons return to their restful state the battery will have 0 volts of difference between both ends.

If we are looking at a 1.5V battery then the electrons at the negative terminal have 1.5V of more potential energy than the positive terminal.

The chemical reaction caused the electrons to gain energy when compared to the (+) terminal.

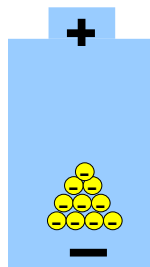

The (-) end has 1.5V more potential than the (+) end

So what would happen when we put one battery on top of the other? Remember that the (-) terminal is 1.5V greater than the (+) end.

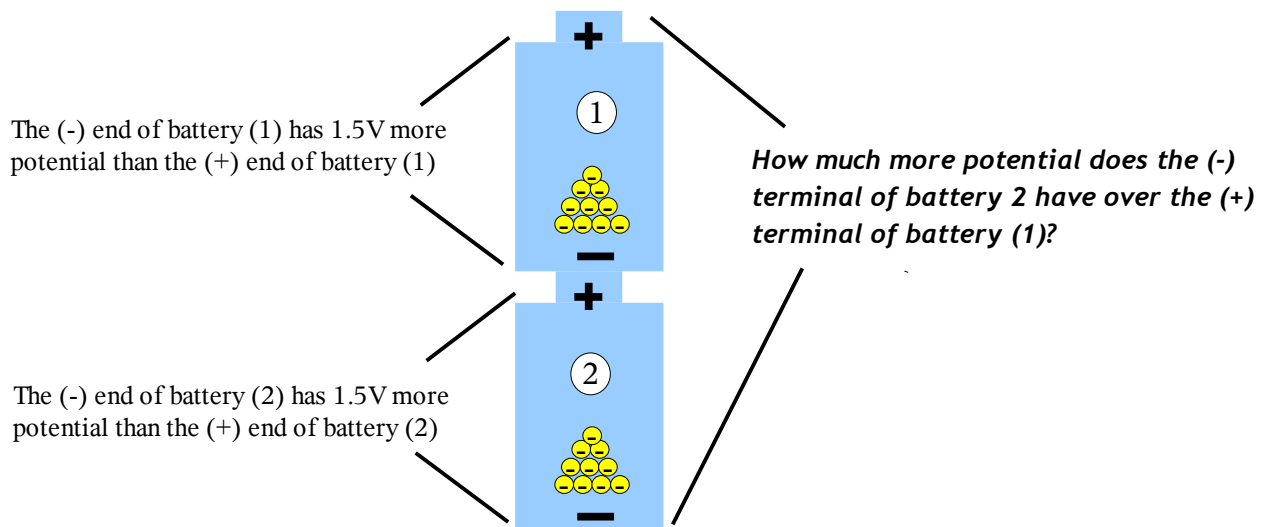

Batteries Unit

Using the Multi-Meter to Measure Voltage

A multi-meter is a tool that can measure many different types of electricity related properties (hence the name). The meter you are using is shown below.

Multi-Meter Handling Tips:

- ***Please don't hold the meter or move the meter by dangling the meter by the test probes. This WILL cause the wires to break inside the probes.***
- ***Please turn the dial slowly. Quickly turning the dial will result in damage to the pieces inside.***

Today we'll be measuring DC voltage. One needs to be careful to use the meter properly otherwise damage can occur to the meter or the user. When measuring DC voltage the dial needs to be in the DCV area circled below. The meters need to be set to the proper range to work properly.

DCV Setting Value	Meaning
1000	The meter can measure between 200V and 1000V
200	The meter can measure between 20V and 200V
20	The meter can measure between 2000milli-Volts and 20 V
2000m	The meter can measure between 200milli-Volts and 2000 milli-volts
200m	The meter can measure between 0V and 200milli-volts

You'll be measuring voltages under 20V but more than 2000milli-volts so set the meter to 20.

Connect the red probe to the (V- Ω - mA) port and the ground to COM port as shown below. This is the proper setting to measure Voltages, Resistances, and small (milli) Current.

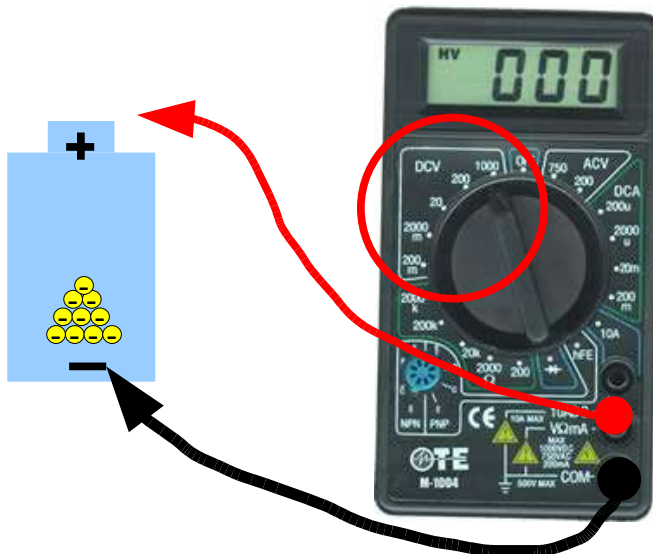

Measure the voltage of Battery 1 and record here:

Batteries Unit

In the next series we will measure the voltages of the individual batteries in series and then the total voltage of the stack when they are put in series.

Step1: Measure the voltage of Battery 1 and record below

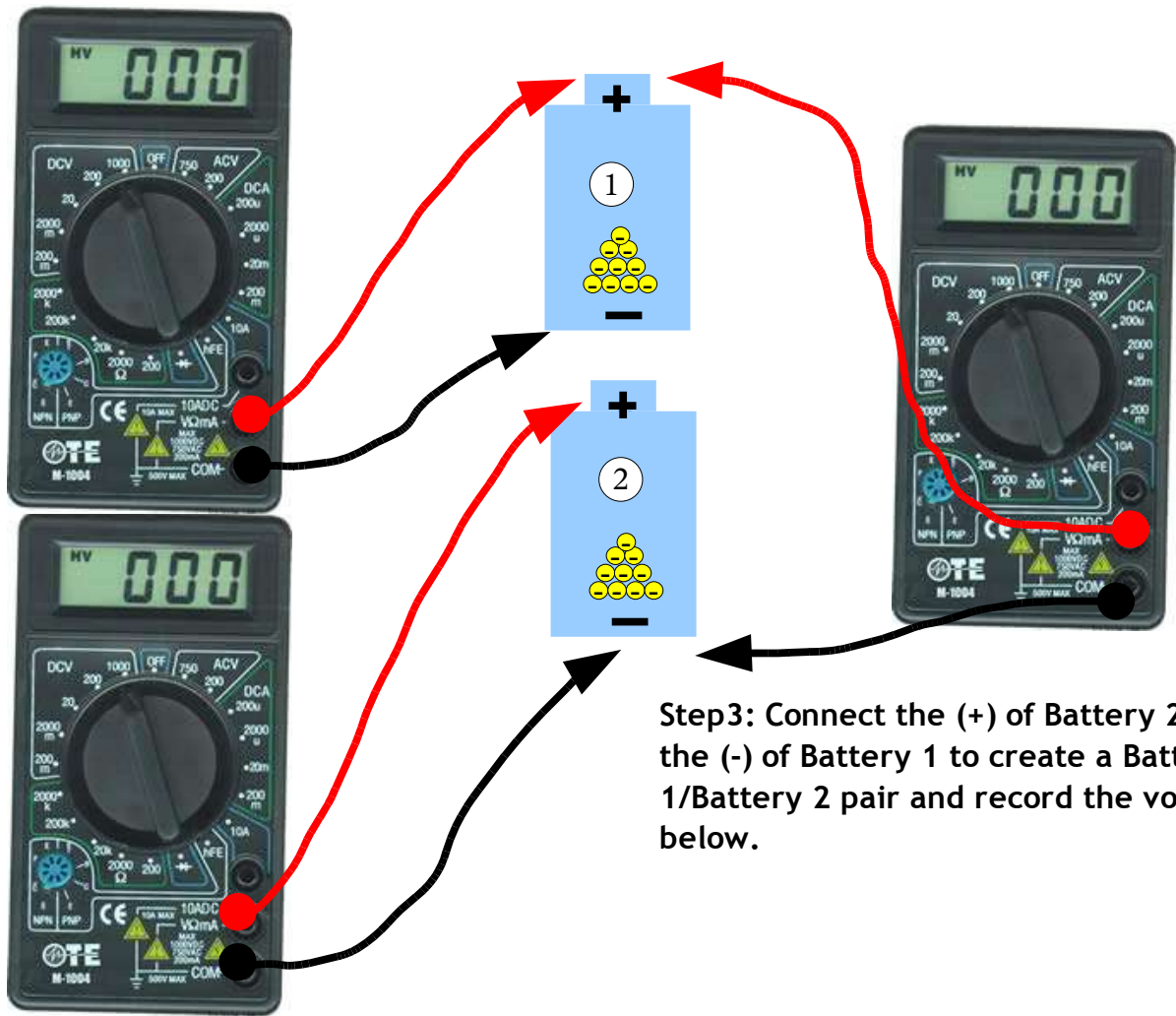

Step3: Connect the (+) of Battery 2 to the (-) of Battery 1 to create a Battery 1/Battery 2 pair and record the voltage below.

Step2: Measure the voltage of Battery 2 and record below,

Step 1 (Battery 1 voltage):

Step 2 (Battery 2 voltage):

Step 3 (Battery 1/Battery 2 pair voltage):





Perform the following arithmetic:

Battery 1 voltage + Battery 2 voltage =

Compare this voltage with what you measured in step 3 and discuss:

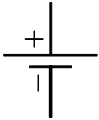
Batteries Unit

Various Circuit Symbols

What we see	How it is represented
 batteries	
Wires	
Resistors, light bulb, heater, radio, anything that uses electricity	
Capacitors	

Batteries Unit Series Discussion

In sports series like The World Series the team must play one game at a time. In track a runner needs to run over a series of hurdles, one hurdle at a time. In electricity, we use the same terminology for a circuit where the electron must run through one object before it can go to the next one.

In the figure below, Electron-Man is carrying an electron from the negative terminal of the battery to the positive terminal of the battery. To get there, he must run through obstacle 1 and after completing obstacle one he enters obstacle 2. This would be considered a series circuit because the electron cannot run through obstacle 2 without going through obstacle 1. The flow of electrons (current) **MUST** go through 1 before getting to 2 and finally arriving at the battery, 3.

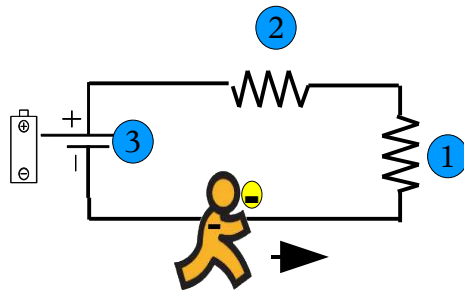

This can be drawn in many different ways but the **ONLY** question that you need to ask yourself is, “Can the electron get the (+) terminal without going through every obstacle?” If the answer is no, then you've identified a series circuit.

Q1: Identify the series circuits below,

It usually helps to draw the electron flow(s) using arrows to show the different paths.

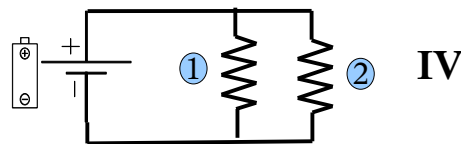
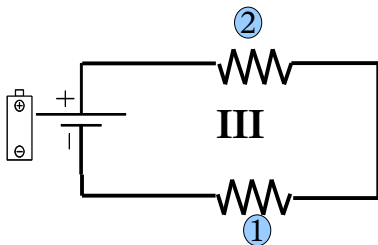
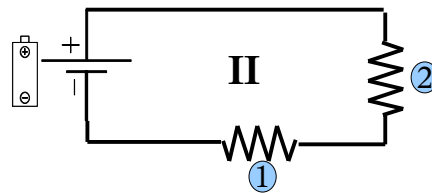
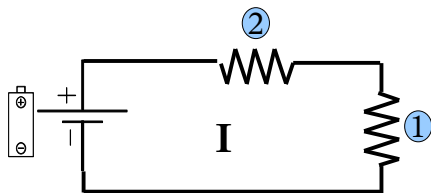

Q2: Is there a difference to Electron-Man between circuits I, II, III, and IV? If not, which ones are the same. If so, which ones are different and why?

Batteries Unit

Series Circuit - LAB

Group Names _____

I. Series Circuit Setup

Find a way to set up a series circuit using 4 alligator clips, the circuit board, and a battery. Make sure that all three resistors are part of your circuit. Draw a circuit diagram for your circuit using the correct symbols.

Have Mrs. George okay your circuit before moving on.____

II. Connect the circuit and write down what happens. Give each bulb a brightness rating (from 1-10).

III. Now, unscrew one of the light bulbs. Give each bulb in the circuit a brightness rating. What happens? Why do you think this happens?

IV. Now exclude one light bulb from the circuit and reconnect the circuit. Give each bulb in the circuit a brightness rating. What happens? Why do you think this happens?

Batteries Unit

- V. Now exclude another light bulb from the circuit and reconnect the circuit. Give each bulb in the circuit a brightness rating. What happens? Why do you think this happens?
- VI. Now try to create a short circuit. A short circuit is an unintended path that usually bypasses resistors. Draw your short circuit using a circuit diagram. Explain what happens when you create your short circuit.
- VII. Summarize your observations about series by listing 3 patterns that you noticed.

Batteries Unit Parallel Discussion

In math, a set of parallel lines contains two lines that are running side-by-side. In gymnastics, the parallel bars are two bars that run along each other but at different heights. Some streets run parallel to each other and cars park parallel to each other in a parking lot. In electricity, we use the same word to describe when an electron can flow through one obstacle without being forced to run through another one.

In the figure below, Electron-Man is carrying an electron from the negative terminal of the battery to the positive terminal of the battery. To get there, he can run through obstacle 1 or obstacle 2 to get to the (+) battery terminal. This would be considered a parallel circuit because the electron isn't forced to run through one obstacle to get to the other. The flow of electrons can go through EITHER 1 or 2 before finally arriving at the battery, 3.

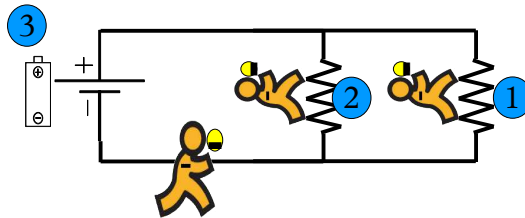

This can be drawn in many different ways but the ONLY question that you need to ask yourself is, “Can the electron get the (+) terminal without going through every obstacle?” If the answer is yes, then you've identified a parallel circuit.

Q1: Identify the series circuits below,

It usually helps to draw the electron flow(s) using arrows to show the different paths.

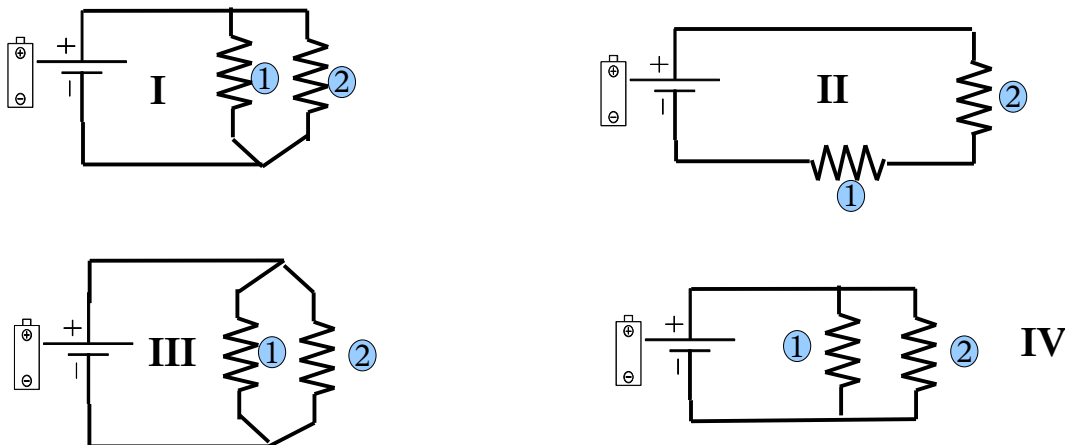

Q2: Is there a difference to Electron-Man between circuits I, II, III, and IV? If not, which ones are the same. If so, which ones are different and why?

Batteries Unit

Series & Parallel Circuit Extra Credit

Identify which parts of the following circuit is in series and which parts are in parallel. You can discuss obstacles as groups if it helps you discuss them but you don't have to.

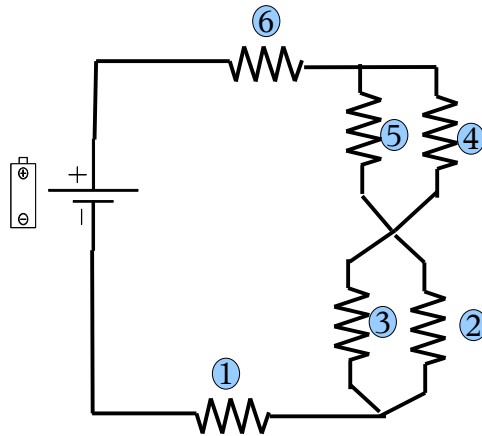

Batteries Unit

Parallel Circuit - LAB

Group Names _____

I. Parallel Circuit Setup

Find a way to set up a parallel circuit using 6 alligator clips, the circuit board, and a battery. Make sure that all three resistors are part of your circuit. Draw a circuit diagram for your circuit using the correct symbols.

Have Mrs. George okay your circuit before moving on.____

II. Connect the circuit and write down what happens. Give each bulb a brightness rating (from 1-10).

III. Now, unscrew one of the light bulbs. Give each bulb in the circuit a brightness rating. What happens? Why do you think this happens?

IV. Now exclude one light bulb from the circuit and reconnect the circuit. Give each bulb in the circuit a brightness rating. What happens? Why do you think this happens?

Batteries Unit

V. Now exclude another light bulb from the circuit and reconnect the circuit. Give each bulb in the circuit a brightness rating. What happens? Why do you think this happens?

VI. Now brainstorm some ways you might like to reconnect the circuit. Pick one of these ways and draw a circuit diagram below first.

Make a prediction about what will happen when you hook it up. Why do you think this will happen?

Now hook it up, what happens?

VII. Summarize your observations about parallel by listing 3 patterns that you noticed.

Batteries Unit

Current and Voltage Unit – Series Circuits

As you've seen, Electron-Man carries the electrons from the (-) terminal to the (+) terminal of the battery. The speed at which the electrons move is called current.

What do you think: *Is the flow of electrons (current) different through obstacle 1 than through obstacle 2?*

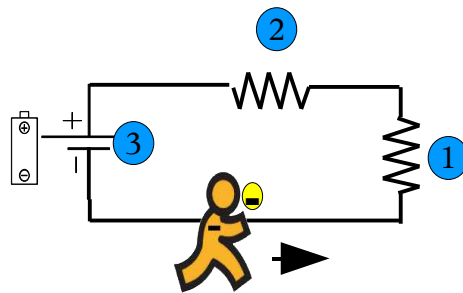

Do we have a way of finding out? YES, the multi-meter!

Measuring Current with the Multimeter:

One of the electrical measurements that the multi-meter can make is current. The way we do this is by using the multi-meter as part of the circuit which is different than when we measure voltage.

- Plug the red probe into the 10A setting on the multi-meter (MM). It is located right above the (V- Ω - mA) port
- Set the multimeter to the 10A setting to measure currents up to 10A. Hopefully we'll be well below that.

Step 1: Measure the current to the first light bulb.

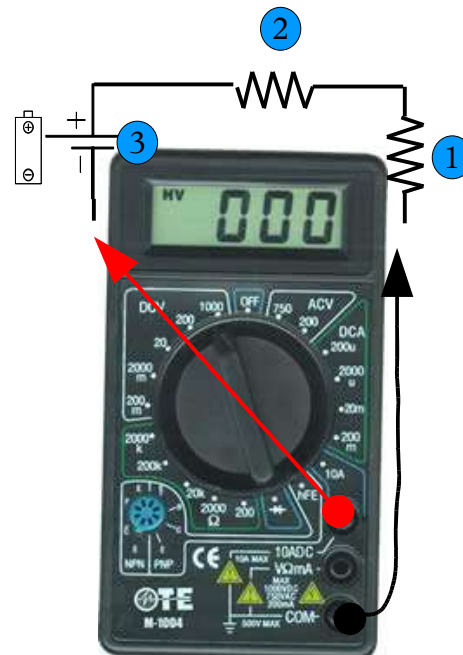

Record your measurement:

Batteries Unit

Step 2: Measure the current between bulb 1 and bulb 2.

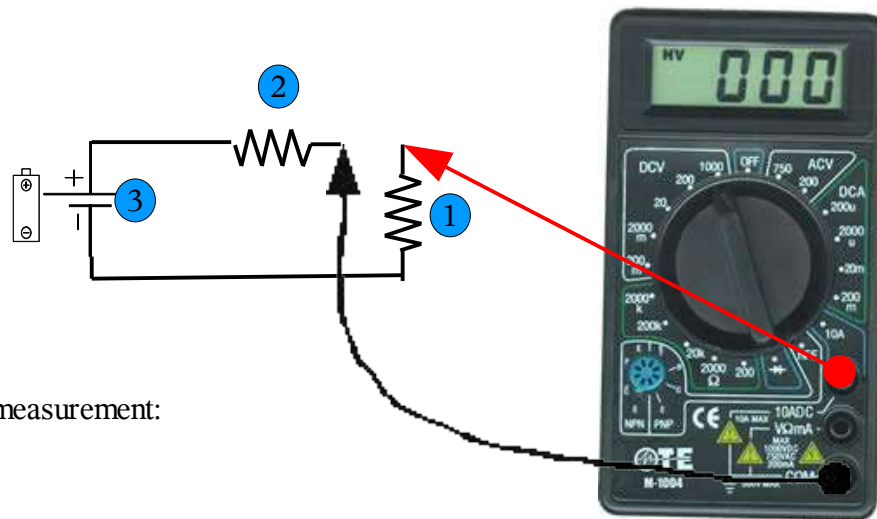

Record your current measurement:

Step 3: Measure the current between bulb 2 and (+) terminal.

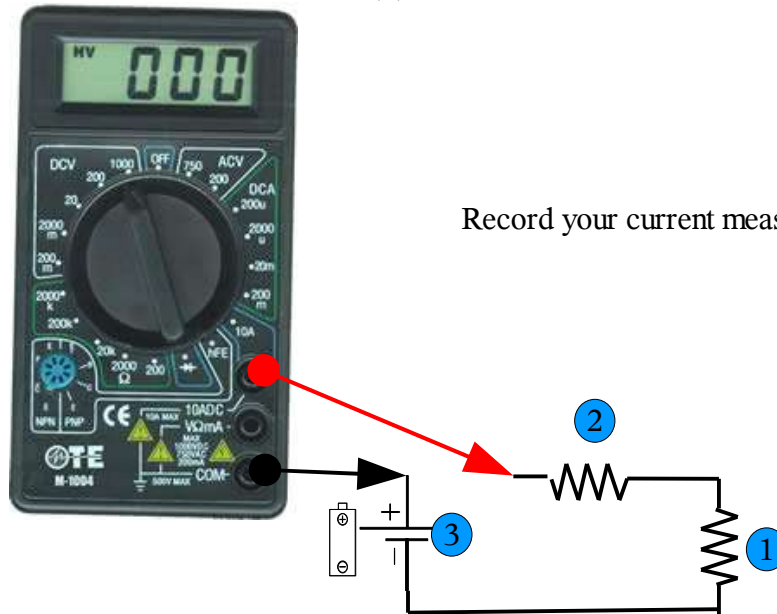

Record your current measurement:

So, what have you learned? Is the current different at different parts of the circuit? Can you make a statement about current and series circuits? Write a few sentences explaining your observations.

Connect the circuit so that both light bulbs are on without using the meter. Now take one light bulb out. What happens? Can you explain?

Make a statement about current and series circuits, something that HAS to be true.

Batteries Unit

Now we're going to explore how the voltage changes as the current flows through the circuit. You'll need to set the MM back to the voltage setting (20 DCV) and put the red probe wire back on the (V- Ω - mA) port. Note that when we measure voltage we don't actually have to create breaks in the circuit like we did when we measured current.

Step 1: Measure the battery voltage in the circuit and record here:

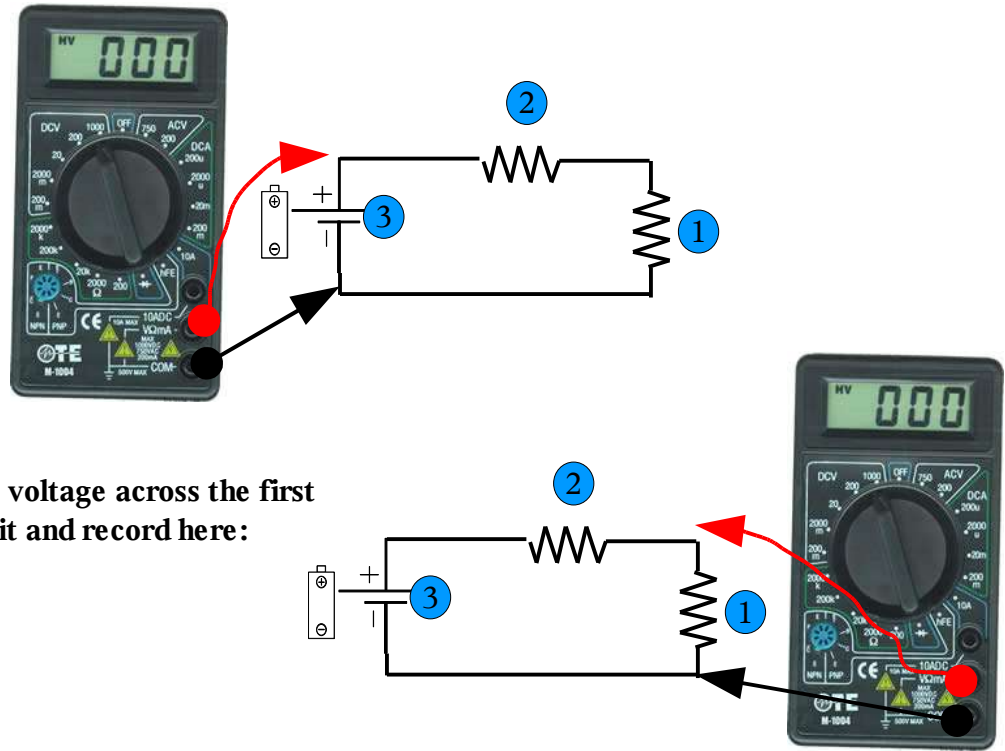

Step 2: Measure the voltage across the first light bulb in the circuit and record here:

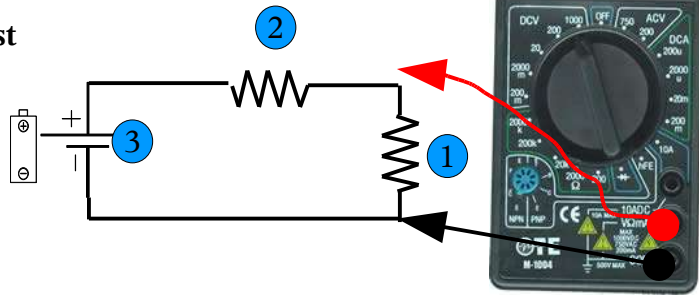

Step 3: Measure the voltage across the second light bulb in the circuit and record here:

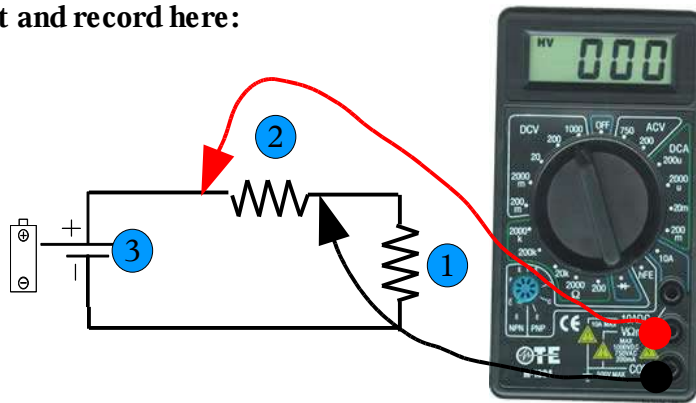

Add the voltages measured at 1 (Step 2) and 2 (Step 3) and compare to the voltage at 3 (Step1). Do you notice anything? Can you explain what is happening in terms of the potential energy of the battery? Write a few sentences explaining what you observed and what you think is happening

How bright are the light bulbs? Can you explain your observation based on the measured voltages?

Make a statement about voltages for series circuits, something that HAS to be true?

Batteries Unit

Current and Voltage Unit – Parallel Circuits

As you've seen, Electron-Man carries the electrons from the (-) terminal to the (+) terminal of the battery. The speed at which the electrons move is called current.

What do you think:

Is the flow of electrons (current) different through obstacle 1 than through obstacle 2?

Is the flow of electrons going into 1 & 2 (big Electron-Man) different than that going through 1 or 2 (smaller Electron-Men)

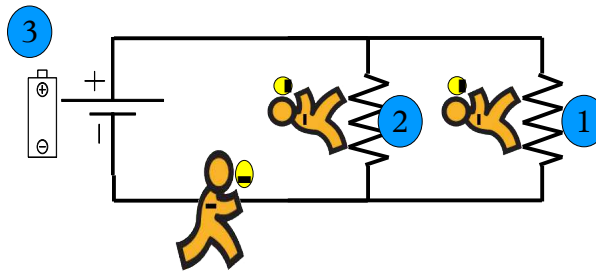

Do we have a way of finding out?

YES, the multi-meter! One of the electrical measurements that the multi-meter can make is current. The way we do this is by using the multi-meter as part of the circuit which is different than when we measure voltage.

- Plug the red probe into the 10A setting on the multi-meter (MM). It is located right above the (V- Ω - mA) port
- Set the multimeter to the 10A setting to measure currents up to 10A. Hopefully we'll be well below that.

Step 1: Measure the current to the first light bulb.

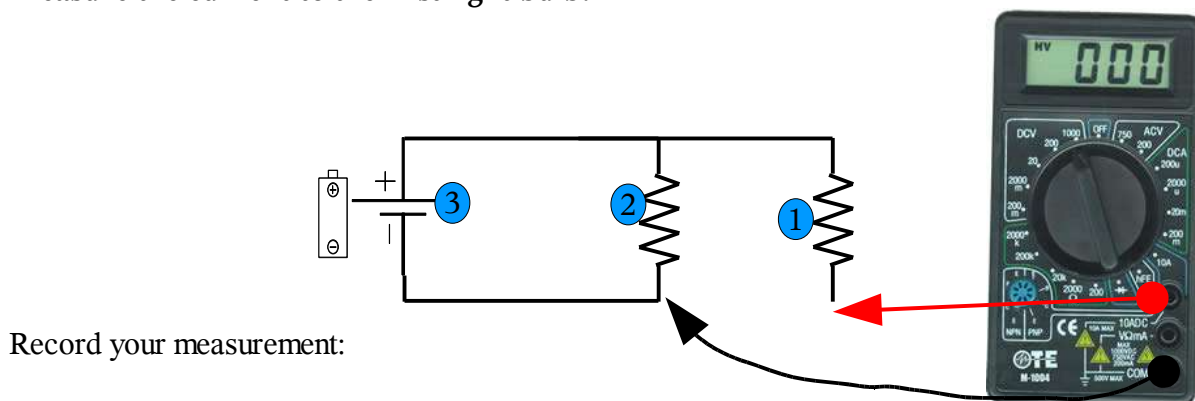

Batteries Unit

Step 2: Measure the current between the battery and bulb 2.

Record your current measurement:

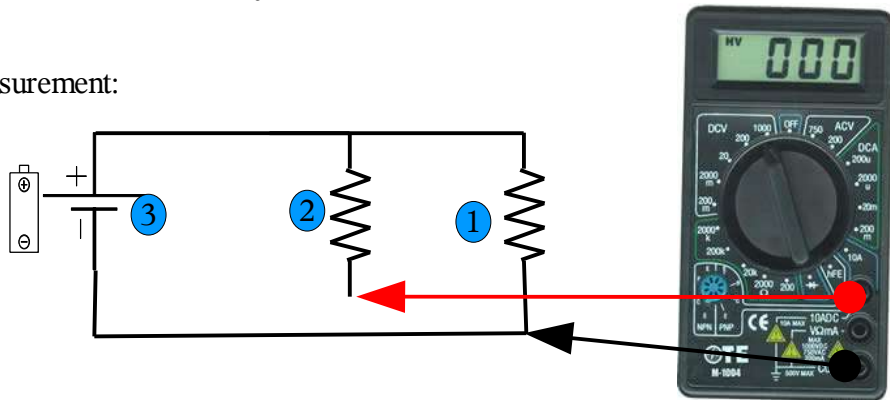

Step 3: Measure the current between the (-) terminal and BOTH bulbs. This is the current going INTO the circuit.

Record your current measurement:

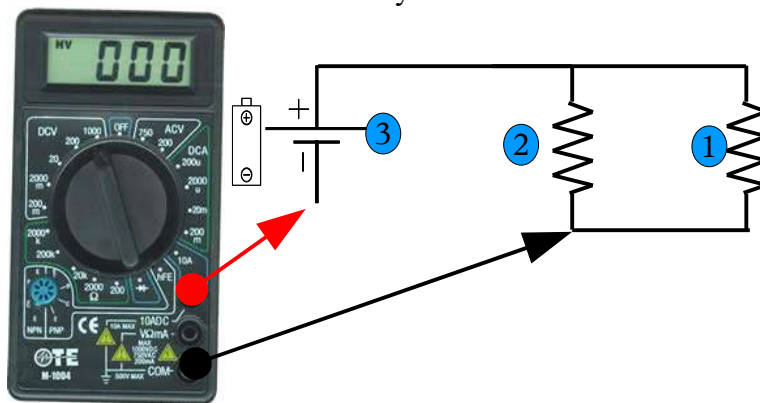

Step 3: Measure the current between the (+) terminal and BOTH bulbs. This is the current coming OUT of the circuit.

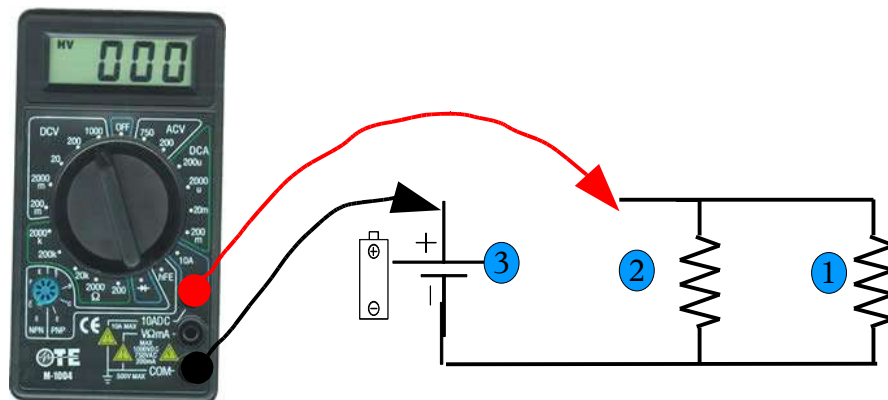

So, what have you learned? **Is the current different at different parts of the circuit?** Can you make a statement about current and parallel circuits? Write a few sentences explaining your observations.

Batteries Unit

Connect the circuit so that both light bulbs are on without using the meter. Now take one light bulb out. What happens? Can you explain?

Are Christmas Tree lights connected in series or parallel, why?

What did you notice about the currents going into and coming out of the circuit?

Add up the currents going through light bulb 1 and light bulb 2 -

Now compare that current to the current coming into and out of the circuit. Make a statement about your observations.

Make a statement regarding current and parallel circuits, something that HAS to be true.

Batteries Unit

Now we're going to explore how the voltage changes as the current flows through the circuit. You'll need to set the MM back to the voltage setting (20 DCV) and put the red probe wire back on the (V- Ω - mA) port. Note that when we measure voltage we don't actually have to create breaks in the circuit like we did when we measured current.

Step 1: Measure the battery voltage in the circuit and record here:

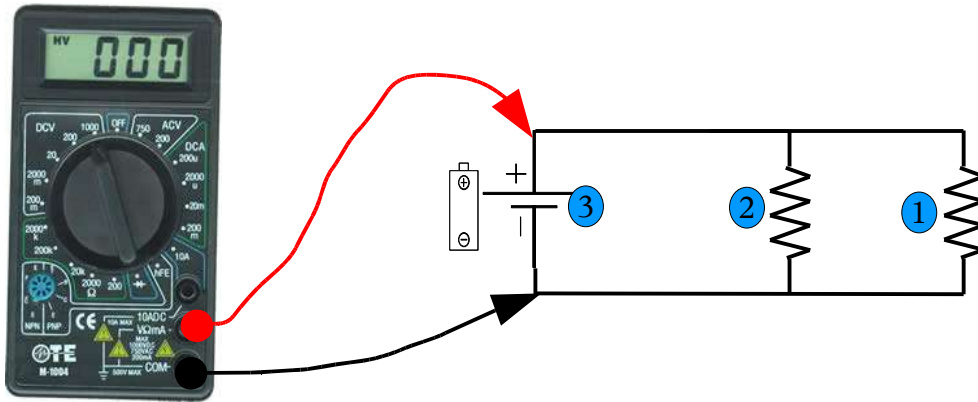

Step 2: Measure the voltage across the second light bulb in the circuit and record here:

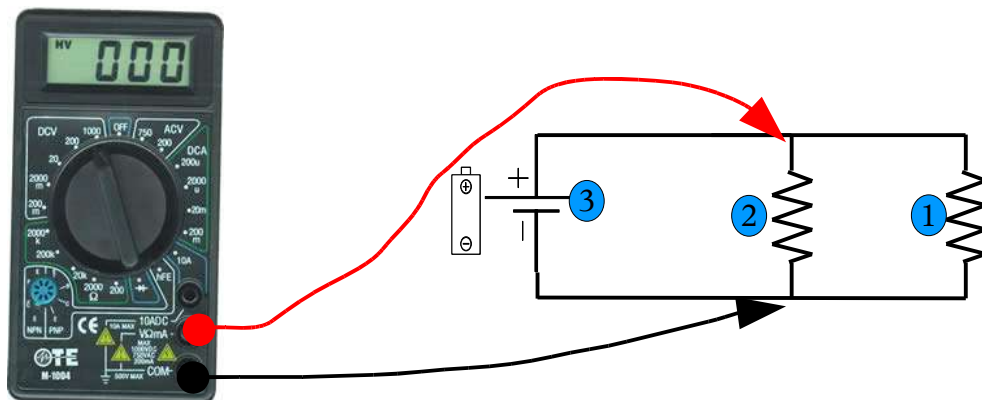

Step 3: Measure the voltage across the first light bulb in the circuit and record here:

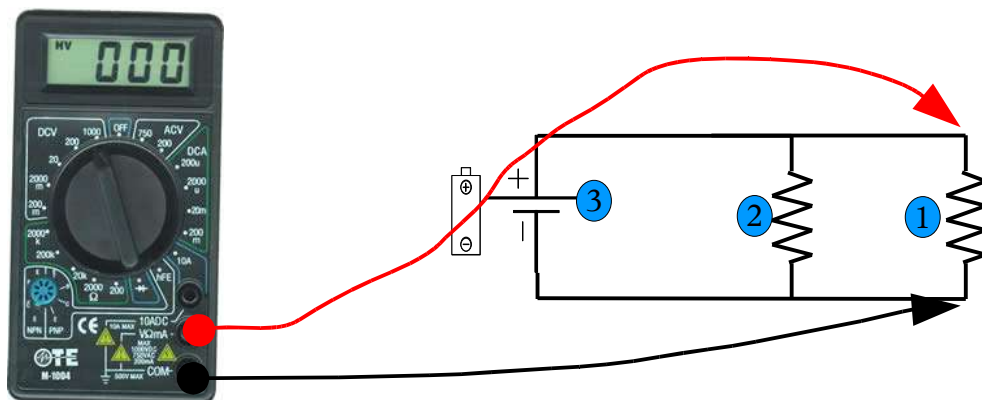

Batteries Unit

Compare the voltages measured at positions 1, 2, and 3. What have you learned?

Do you notice anything? Can you explain what is happening in terms of the potential energy of the battery? Write a few sentences explaining what you observed and what you think is happening

How bright are the light bulbs? Can you explain your observation based on the measured voltages?

Make a statement about voltage and parallel circuits, something that HAS to be true.

Extra Credit

Consider a pair of light bulbs in series compared to a set of light bulbs in parallel. Which would be dimmer? Propose an idea or method to make them brighter using batteries, wires, or light bulbs. You cannot change the configuration of the dimmer light bulb set; this means that if you chose parallel as the dimmer set then the light bulbs must remain in parallel and if you chose series as the dimmer set then the light bulbs must remain in series.

Feel free to draw a sketch below,

Batteries Unit Post-assessment

Name: _____

1. Please draw 2 batteries in series.
2. Please draw 2 batteries in parallel.
3. Please draw 2 light bulbs in series.
4. Please draw 2 light bulbs in parallel.
5. Will the voltage of 2 batteries be greater when in series or in parallel? Why?
6. Assume each battery is 6v. What would the measured voltage be in series and in parallel?
Series voltage:
Parallel voltage:
7. Would light bulbs connected in series or parallel be brighter?
8. Will the current of 2 batteries be greater in series or in parallel? Why?
9. Assume each battery can provide 2A (amps) of current to a light bulb circuit. What would the measured current be in series and in parallel?
Series voltage:
Parallel voltage:
10. Do electrons flow from positive to negative or negative to positive?
11. Explain what happens when you put 2 batteries in series in terms of voltage and current.
Current:
Voltage:

Batteries Unit

12. Explain what happens when you put 2 batteries in parallel in terms of voltage and current.

Current:

Voltage:

13. Explain what happens when you put 2 light bulbs in series in terms of voltage and current.

Current:

Voltage:

14. Explain what happens when you put 2 light bulbs in parallel in terms of voltage and current.

Current:

Voltage: