

Austin Bitting (Agricultural Systems Management)

Background and Objective

- **The Problem** – Dr. Heber’s Electric Power and Controls class needed a lab to demonstrate electric motor characteristics. This lab would allow students to run tests and analyze how a motor’s current draw, speed, and efficiency change under different loads.
- Dr. Heber wanted someone to design and build a small Prony brake dynamometer for \$1500 or less.
- Project shifted focus once an affordable prebuilt Prony brake was found.
- Designed a lab handout and Standard Operating Procedure for a dynamometer station.

Motor Test Procedure

- Attach motor output shaft to dynamometer.
- Tighten brake to cause lever arm to rotate and push down on a scale.
- Record the force measured by the scale
- Calculate motor torque, in lb-ft, by multiplying force (*F*) by length of lever arm (*L*).
- Measure speed (*N*), voltage, current, VA, and PF.
- Repeat test at other load settings.
- Record motor and dynamometer temperatures.
- Calculate motor efficiency at different loads.
- Graph motor performance curve.

Electric Motor Test Characteristics

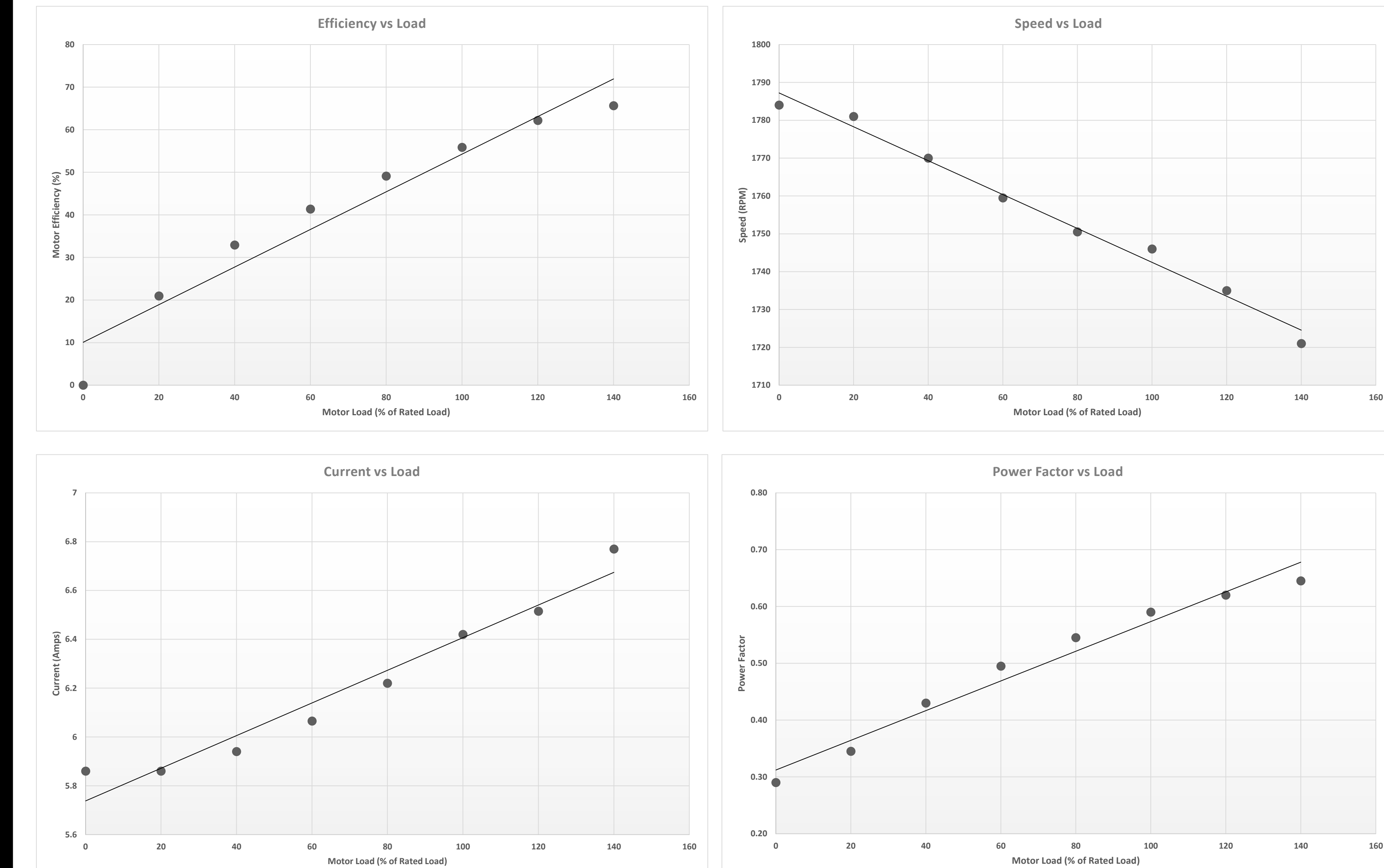

Alternative Ideas and Solutions

- Build our own design of a Prony brake dynamometer.
 - Determine materials to be used.
 - Build all the pieces and the complete dynamometer.
- Find an affordable design that could be improved.
 - Buy a prebuilt Prony brake.
 - Make any necessary improvements.
 - Spend time building the lab and testing tools.
- Dr. Heber and the team decided that buying a Prony brake and building the lab handout and testing station would be a more beneficial solution.
- The team found three companies that sold prebuilt Prony brakes. All had about the same capabilities. One was over budget and another was well under budget (\$710) but was poorly designed. The third was well built and met our budget at \$1,040, and was chosen.



$$Output\ Power\ (hp) = \frac{2\pi FLN}{33,000}$$

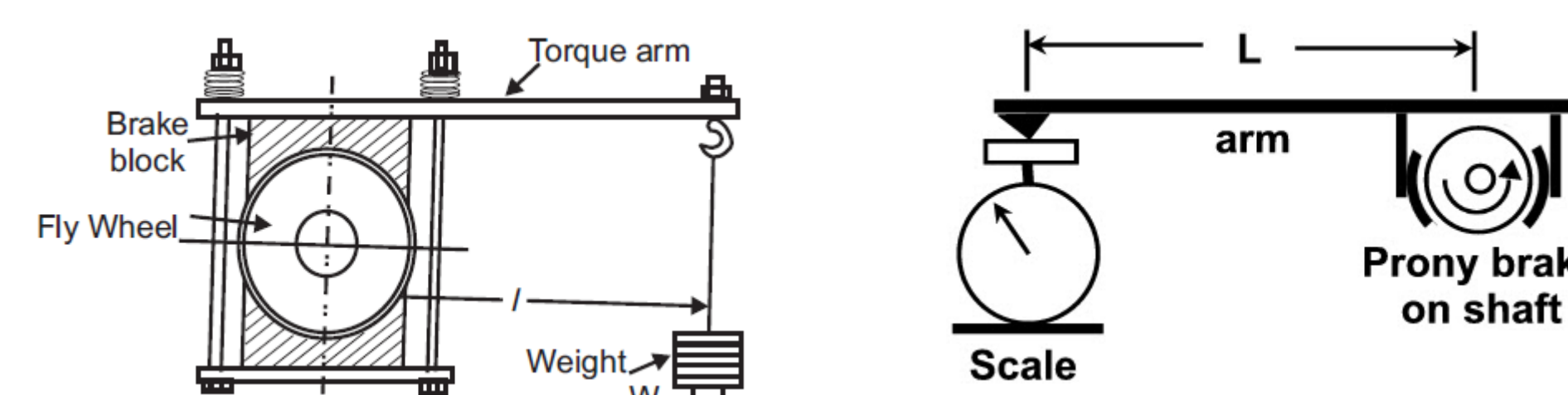

Impact and Sustainability

- Hands-on experience with electric motors. Better understanding of motor characteristics
- The dynamometer system has a 20 yr life expectancy.
- The test station has flexibility to test different motors in the future.
- ASM 420 teaches about many different types of electric motors. In the future Dr. Heber plans to obtain more motors to show students how different motor types have different characteristics.

Lab Handout Worksheet and SOP

- A lab worksheet was designed for students to use in the lab entitled Performance Characteristics of an Electric Motor.
- Dr. Heber did not have any material for teaching the students how to collect the data from the testing station.
- Dr. Heber provided a lab handout from 2002 for the team to build upon.
- Using learning objectives from the provided lab and *Fundamentals of Electricity for Agriculture*, the class textbook, the team put together a useable lab handout.
- A SOP was written for the motor testing station that can be used to aid the students. The SOP can also be used if another class wants to use the stand for demonstration without needing the lab handout.

Budget

Starting Budget	\$1,500
Prony Brake	\$1,040
Electric Motor*	\$150
Bench/Test Stand**	\$200
Hardware	\$15
Meters*	\$60
Photo Tachometer	\$35
Total Cost	\$1,500

*Provided by Dr. Heber
**Provided by Scott Brand

Testing Station Specs

- Hampden Prony brake
- High strength steel
- 72 oz (4.5 lb) scale
- Torque range of 0-2.5 lb-ft
- Up to ¾ hp motor @1725 rpm
- Easy tightening method
- Easily upgradable scale
- Plug-in multimeter
- Photo tachometer
- Temperature sensors
- Clamp-on ammeter



Test station on the bench.

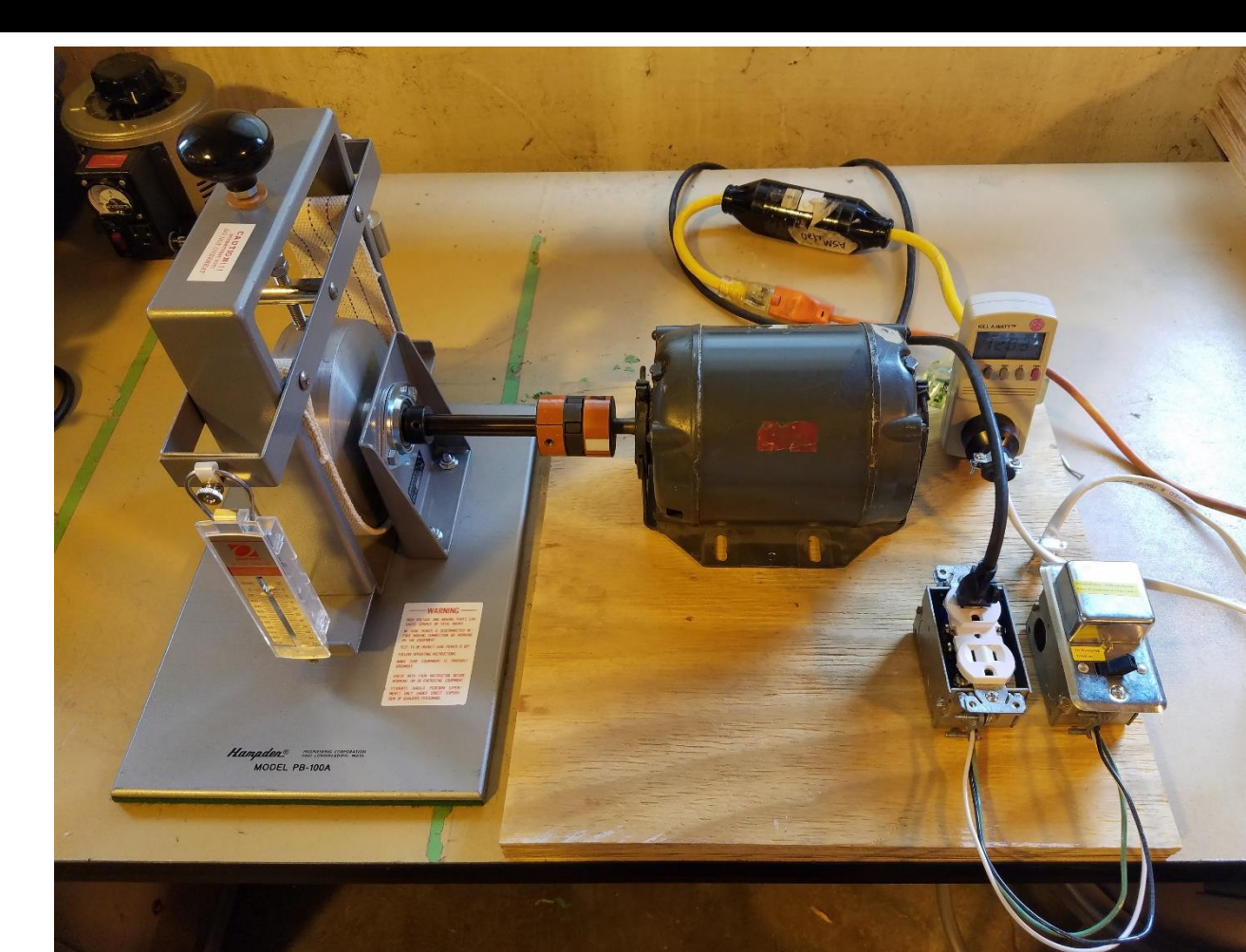

Testing on a table.

Final Evaluation

- Currently, the Prony brake test station is capable of testing motors up to about 3/4 hp. To test larger motors, a bigger scale is needed.
- Equipping the test station with different electric motor types would make the test station more educational because the different characteristics from one motor type to another could be studied.

Sponsor:
Dr. Albert J. Heber
ASM 420 Instructor

Technical Advisor:
Dr. Robert M. Stwalley

Instructors:
Dr. Robert M. Stwalley
Dr. Bernard A. Engel

Acknowledgements:
Hayden Vint
Scott Brand
Hannah Tucker
Provost Instructional Equipment Grant
Dr. Marcos Fernandez, Associate Dean and Director of Academic Programs