

Digital Signal Processing

Fifth Edition

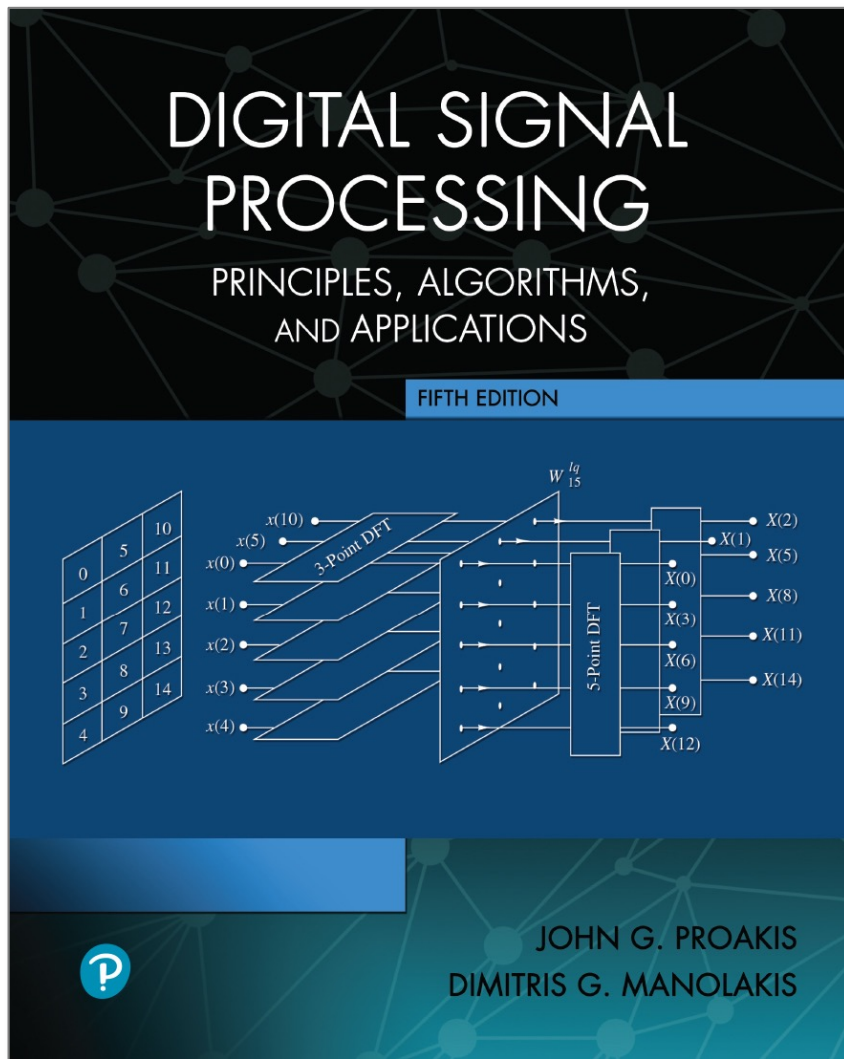

Chapter 6

Sampling and Reconstruction of Signals

Figure 6.1.1 Sampling of an analog bandlimited signal and aliasing of spectral components.

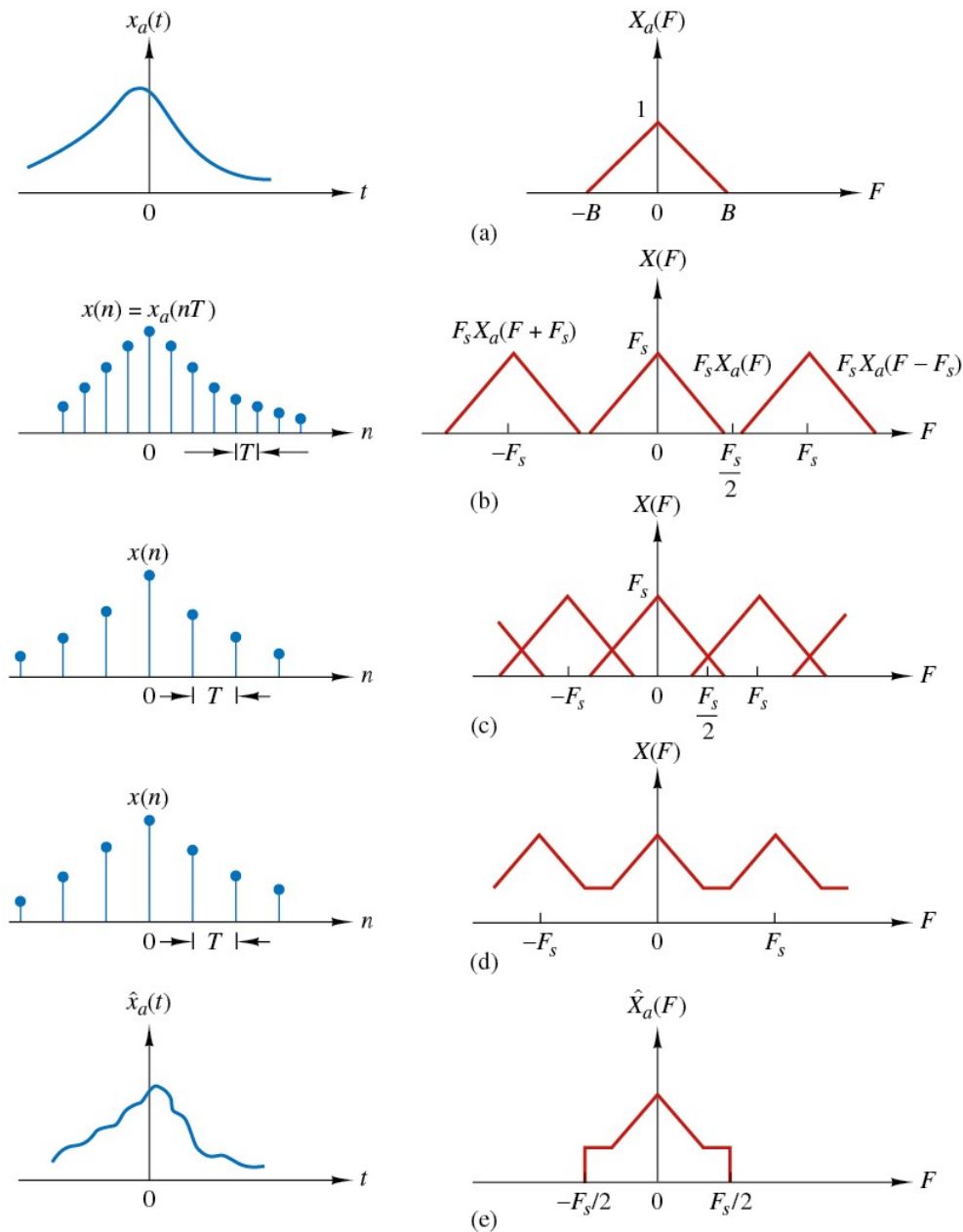

Figure 6.1.2 Reconstruction of a continuous-time signal using ideal interpolation.

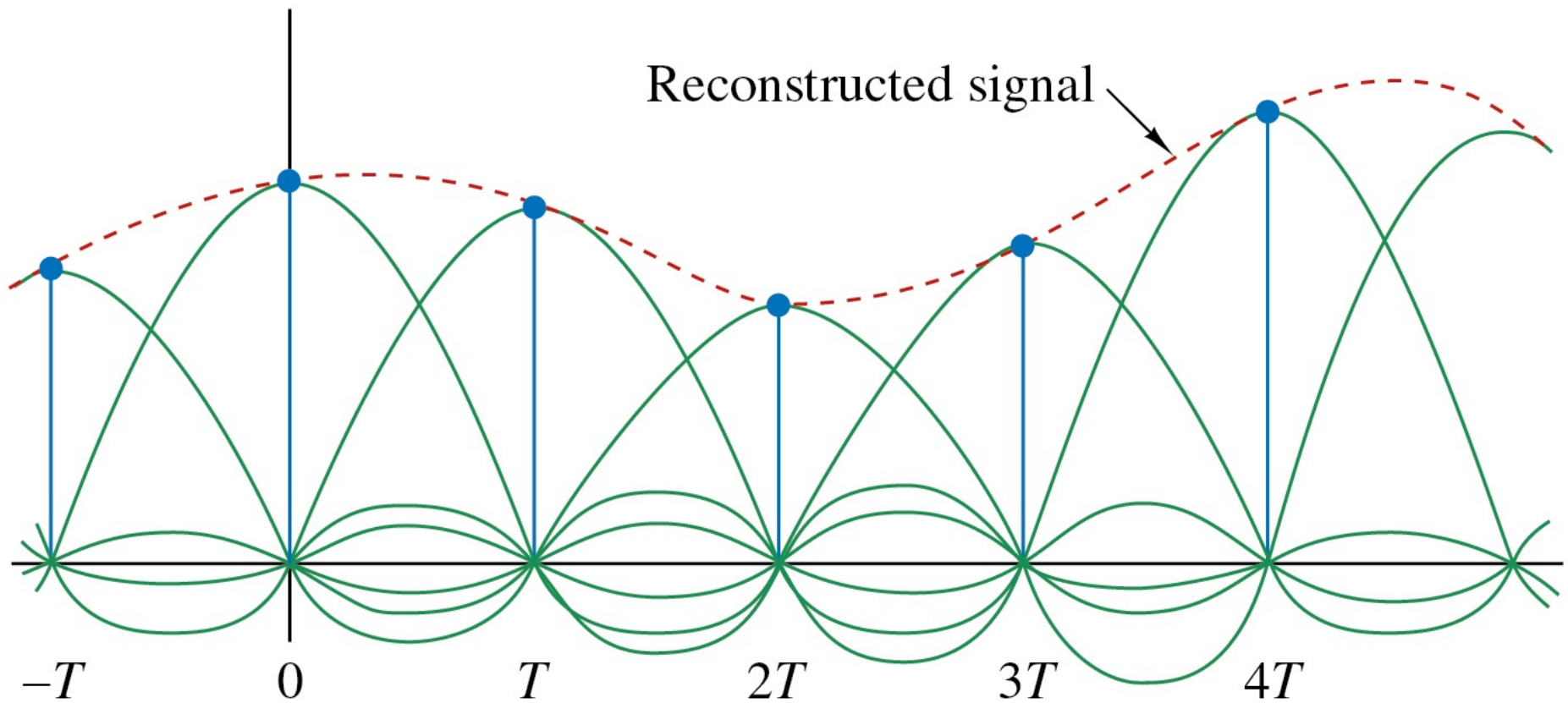

Figure 6.1.3 Illustration of aliasing around the folding frequency.

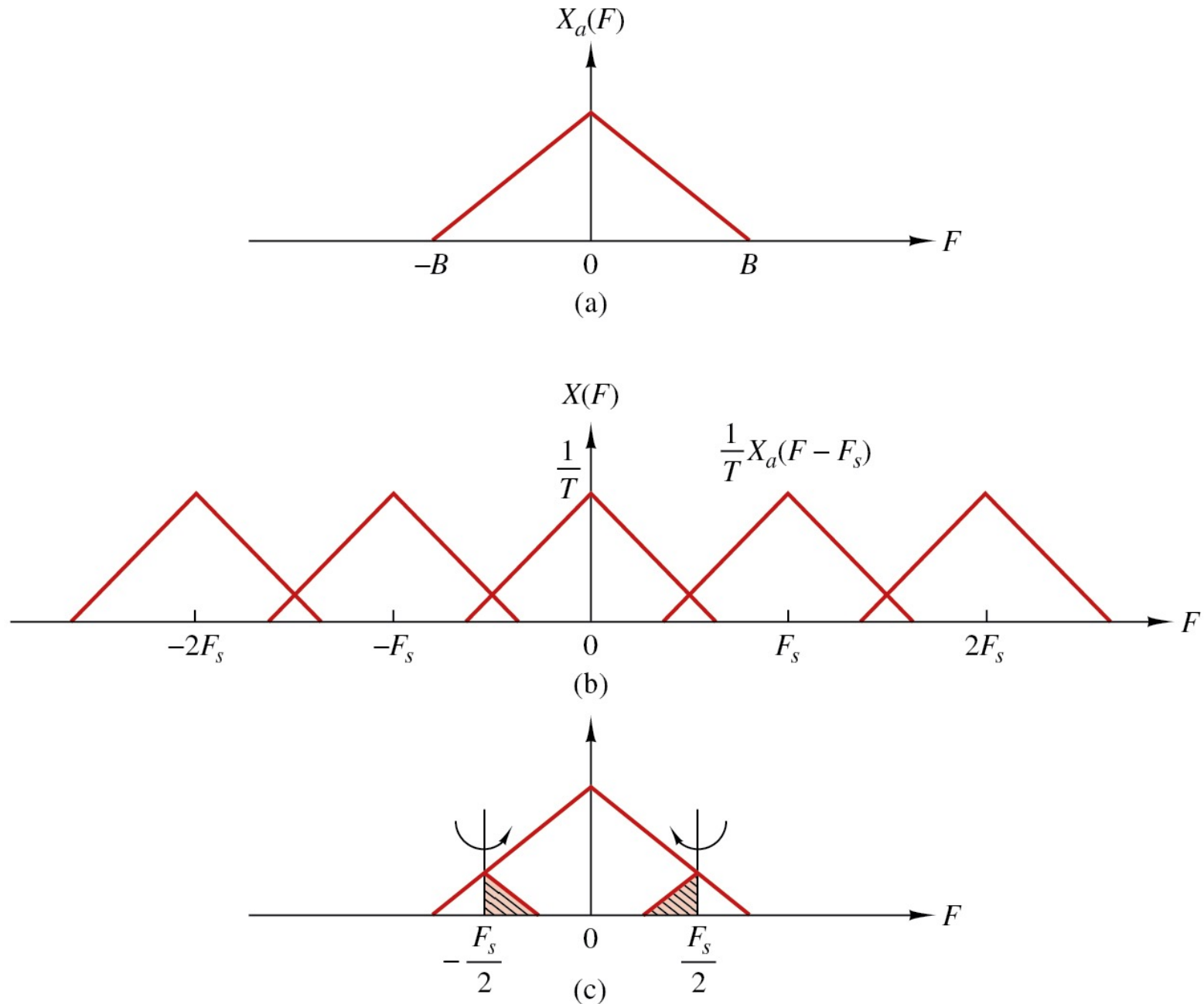

Figure 6.1.4 Relationship between frequency variables F and f .

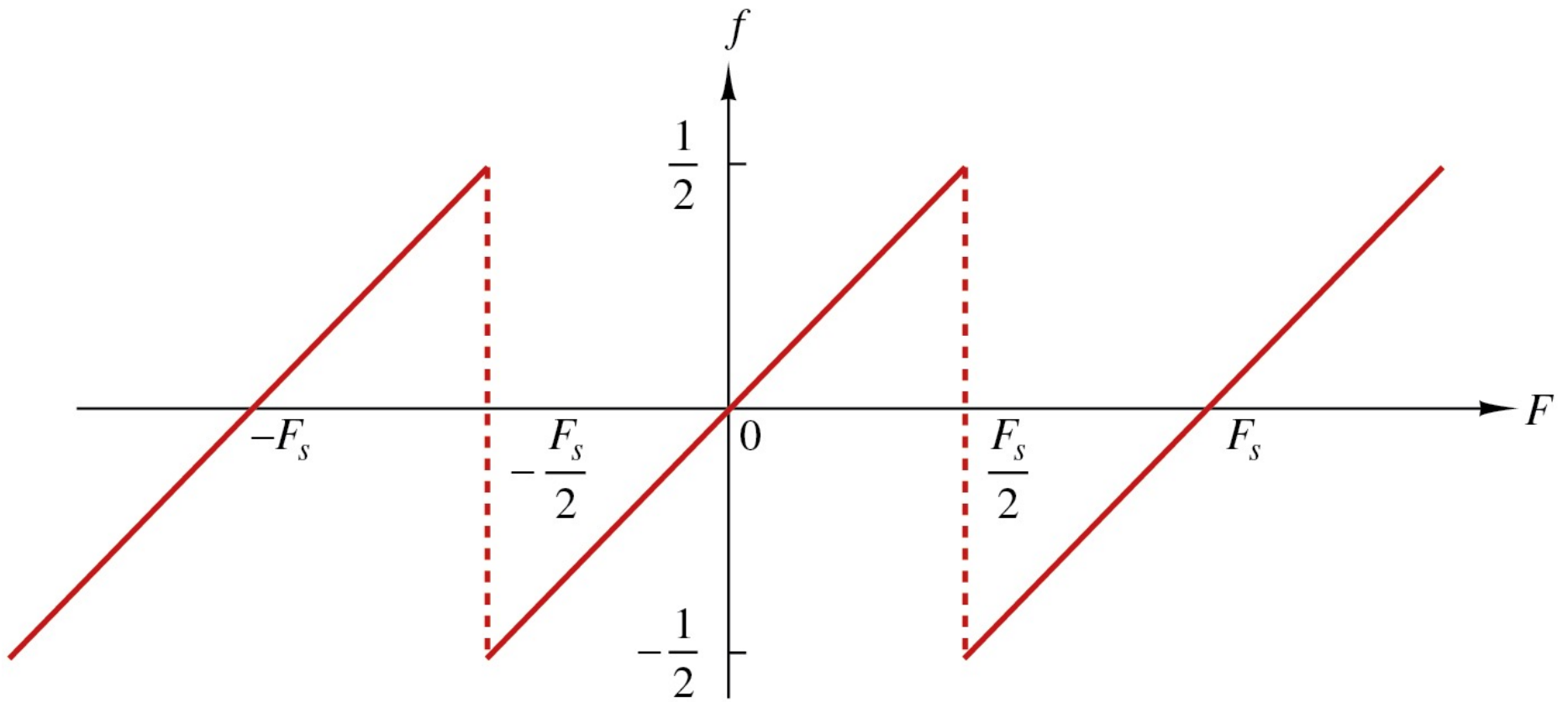

Figure 6.1.5 Time-domain and frequency-domain relationships for sampled signals.

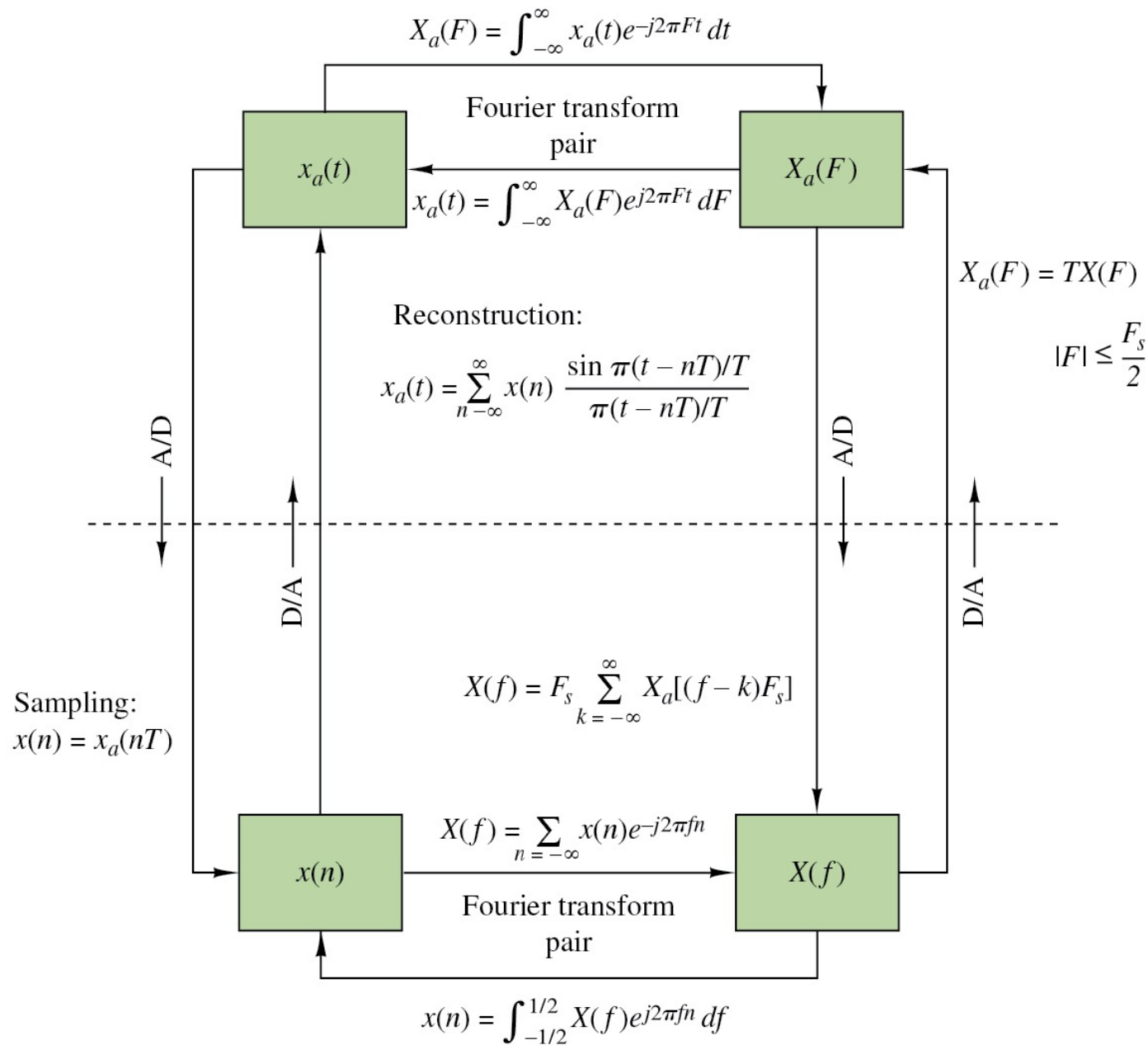

Figure 6.1.6 Aliasing of sinusoidal signals.

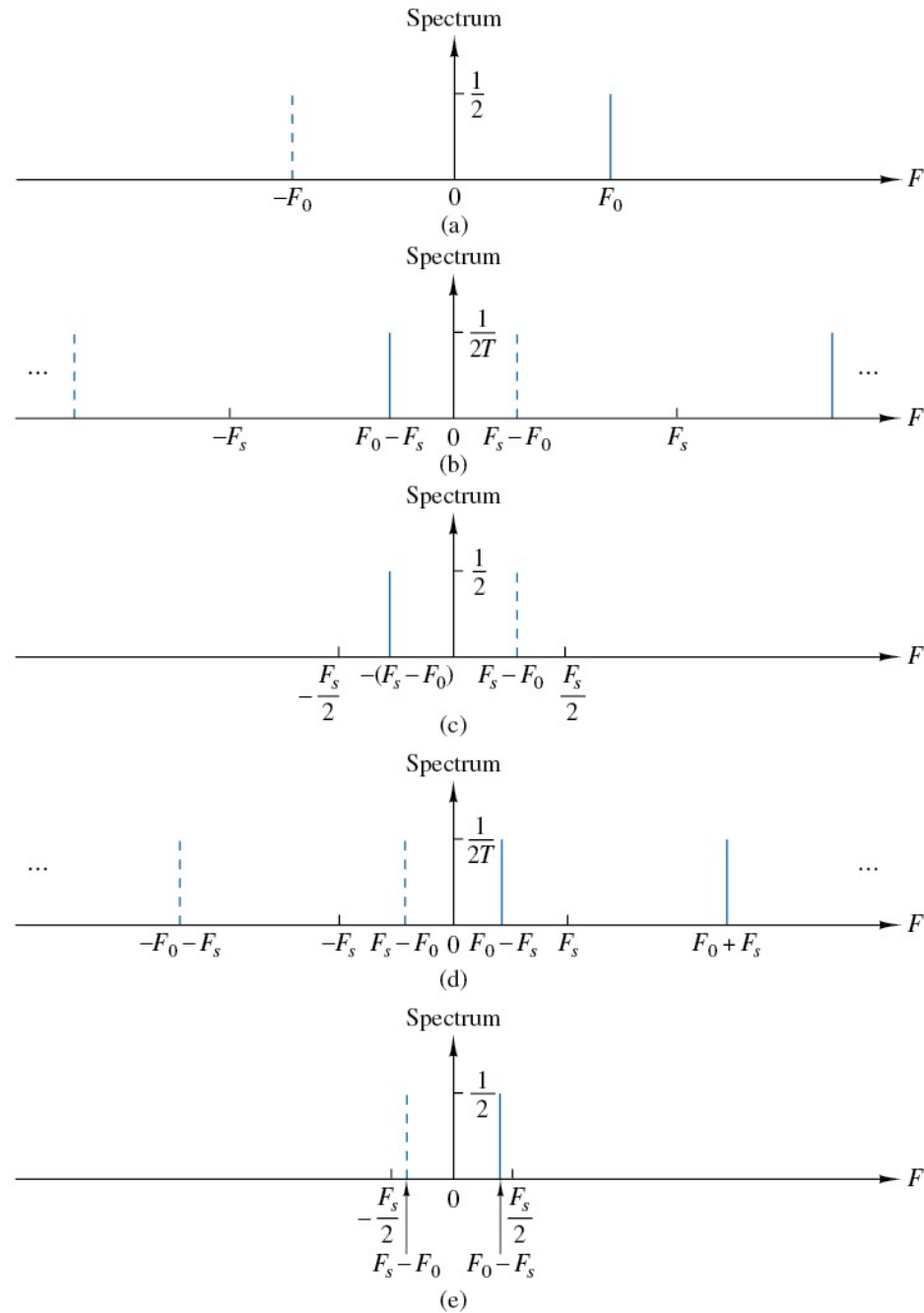
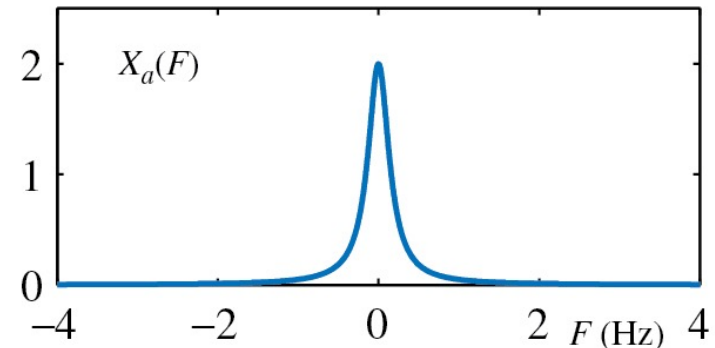
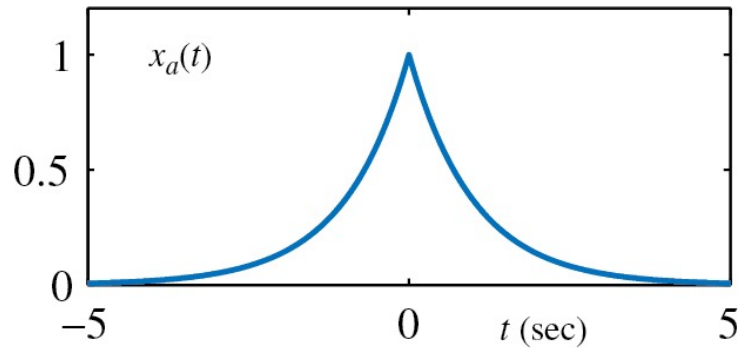
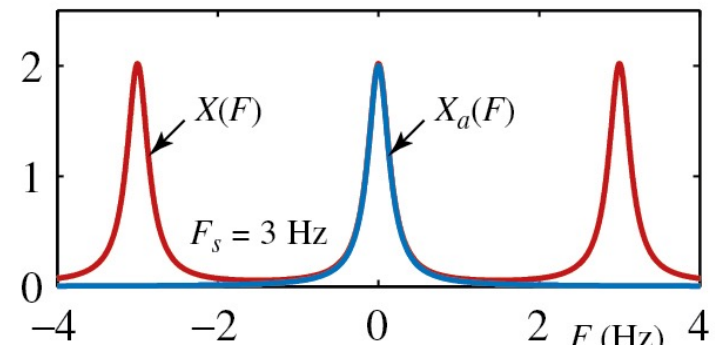
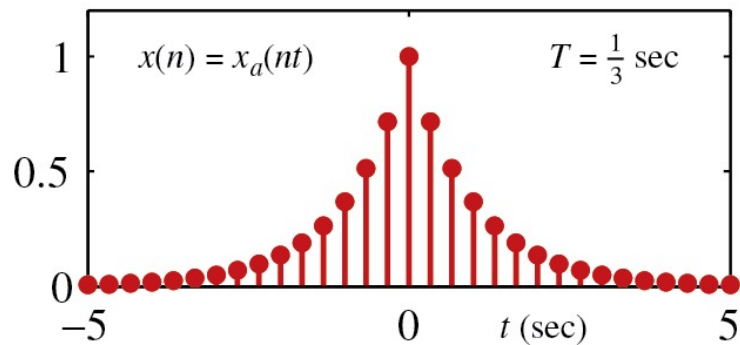

Figure 6.1.7 (a) Analog signal $x_a(t)$ and its spectrum $X_a(F)$; (b) $x(n) = x_a(nT)$ and its spectrum for $F_s = 3$ Hz; and (c) $x(n) = x_a(nT)$ and its spectrum for $F_s = 1$ Hz.



(a)



(b)

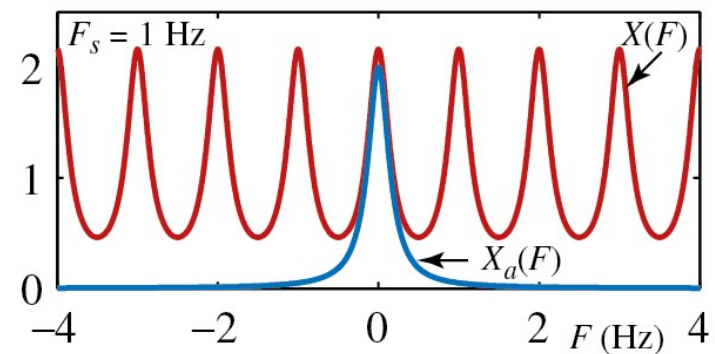
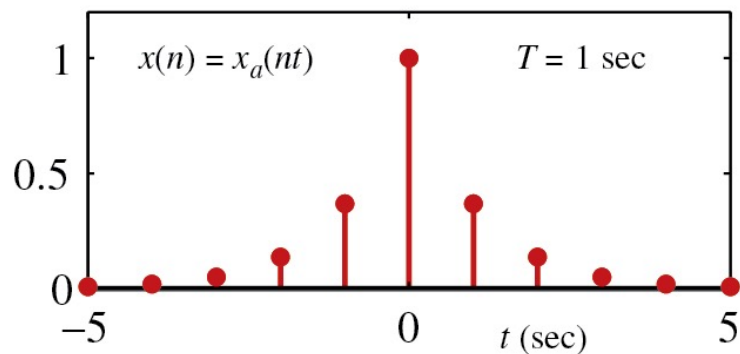

(c)

Figure 6.1.8 (a) Analog signal $x_a(t)$ and its spectrum $X_a(F)$; (b) reconstructed signal $\hat{x}_a(t)$ and its spectrum for $F_s = 3$ Hz; and (c) reconstructed signal $\hat{x}_a(t)$ and its spectrum for $F_s = 1$ Hz.

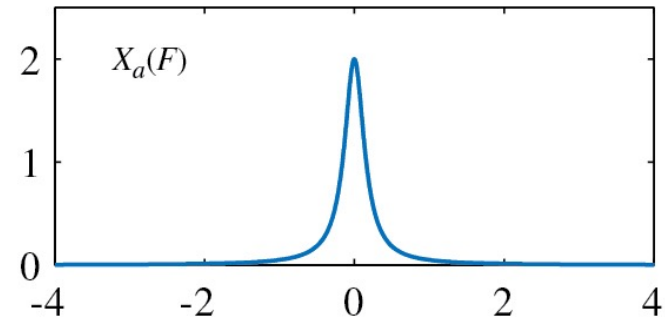
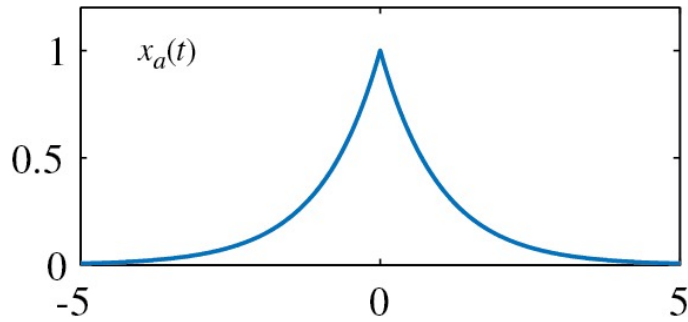

(a)

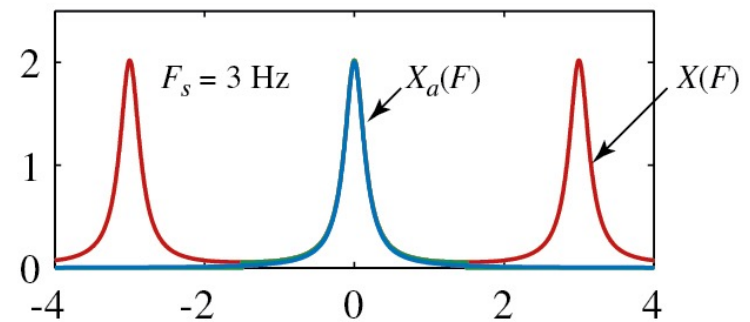
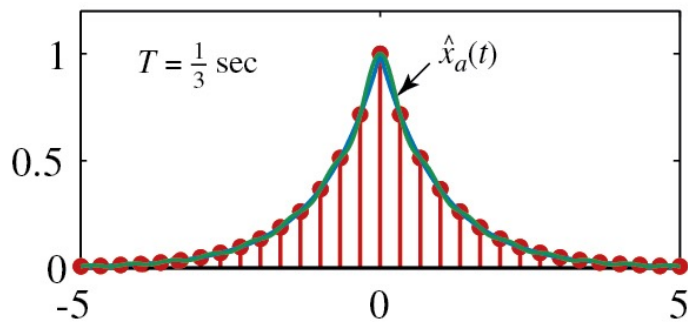

(b)

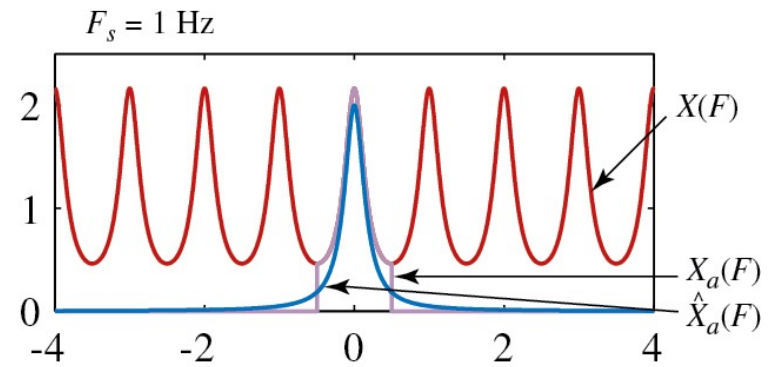
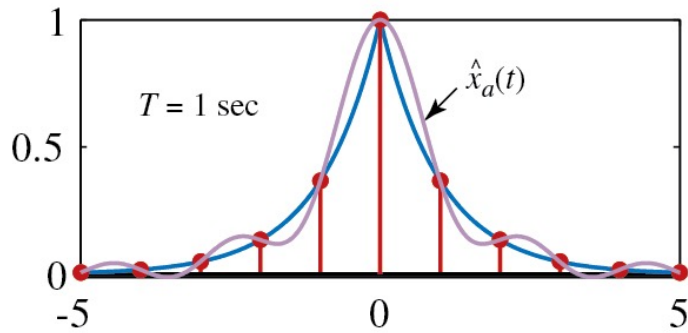

(c)

Figure 6.2.1 System for the discrete-time processing of continuous-time signals.

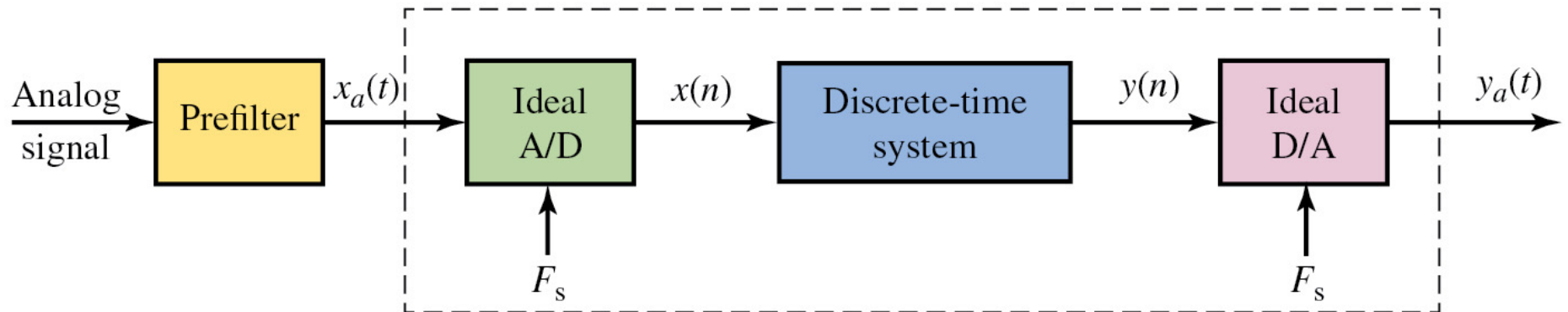

Figure 6.2.2 Characteristics of an ideal A/D converter in the time and frequency domains.

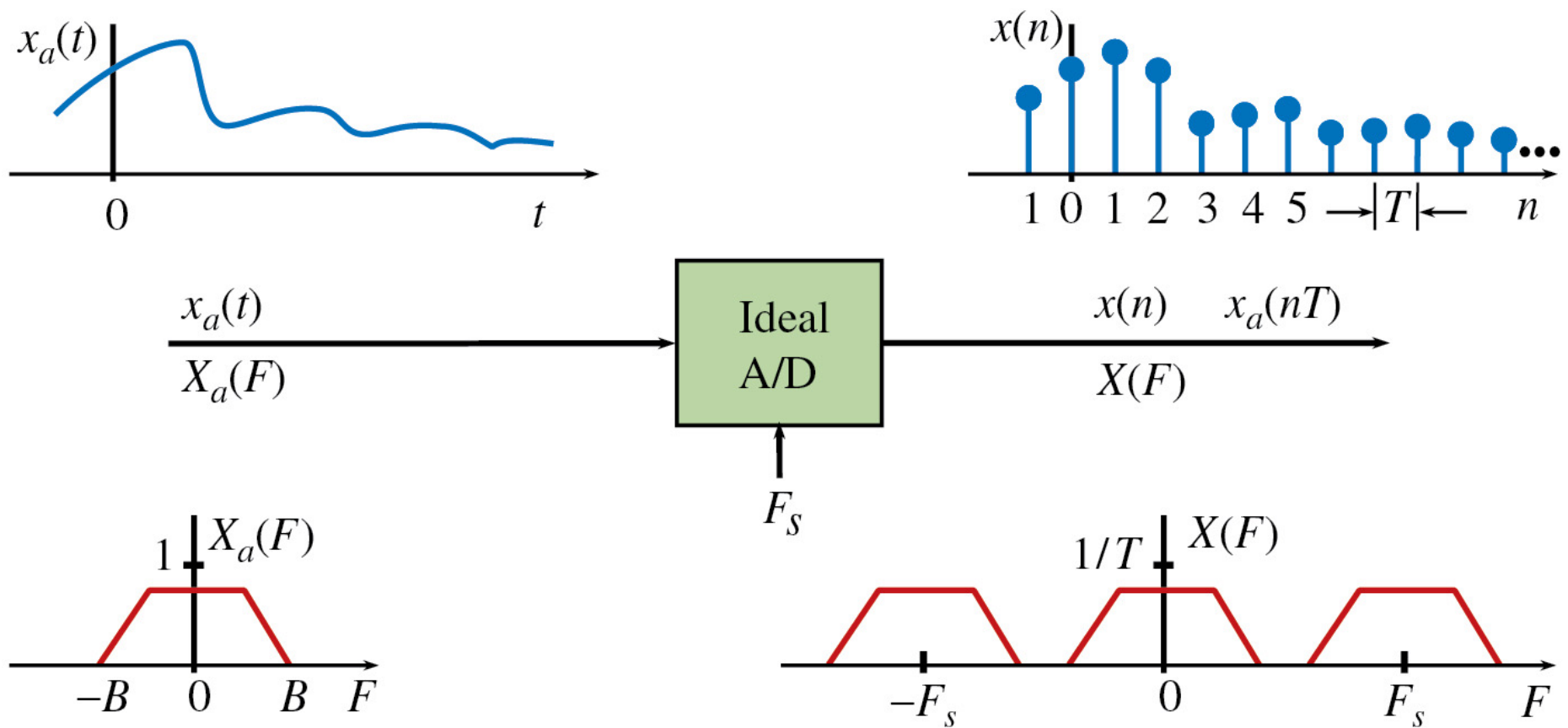

Figure 6.2.3 Characteristics of an ideal D/A converter in the time and frequency domains.

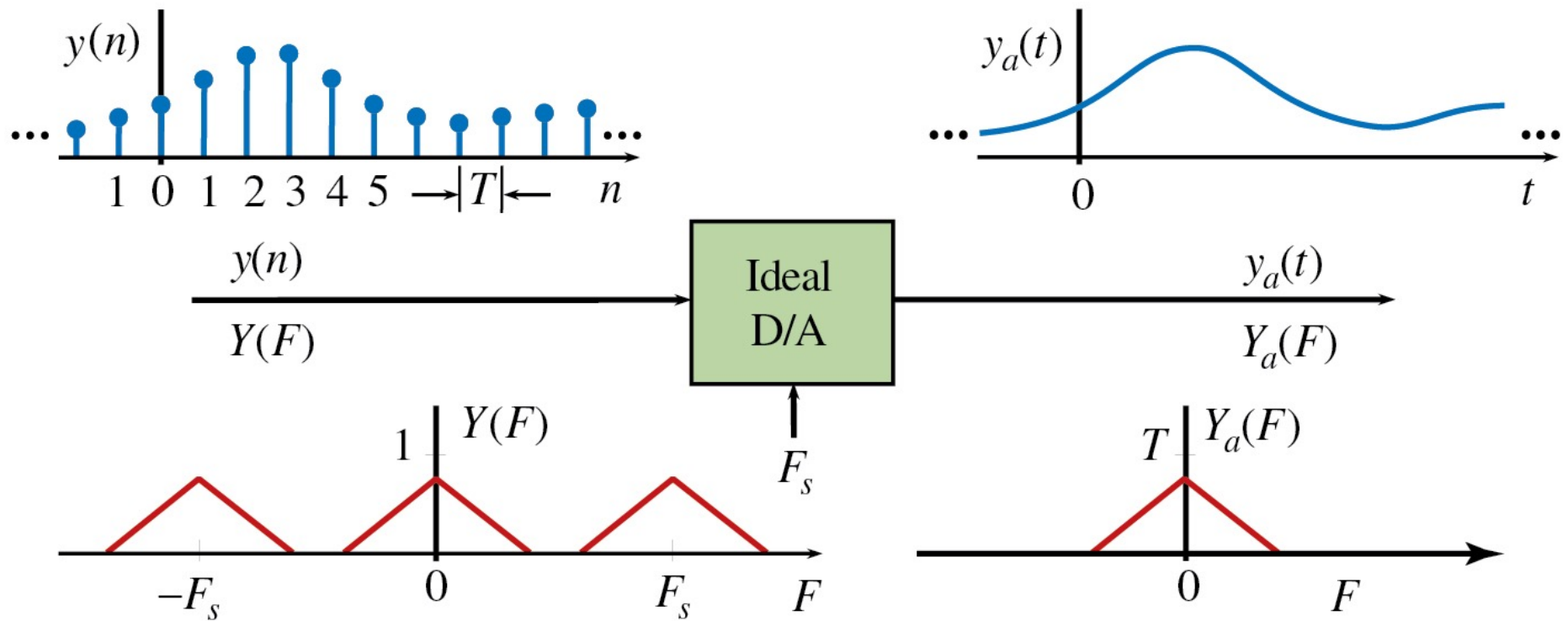

Figure 6.2.4 Discrete-time implementation of an analog integrator using impulse response sampling. The approximation is satisfactory when the bandwidth of the input signal is much less than the sampling frequency.

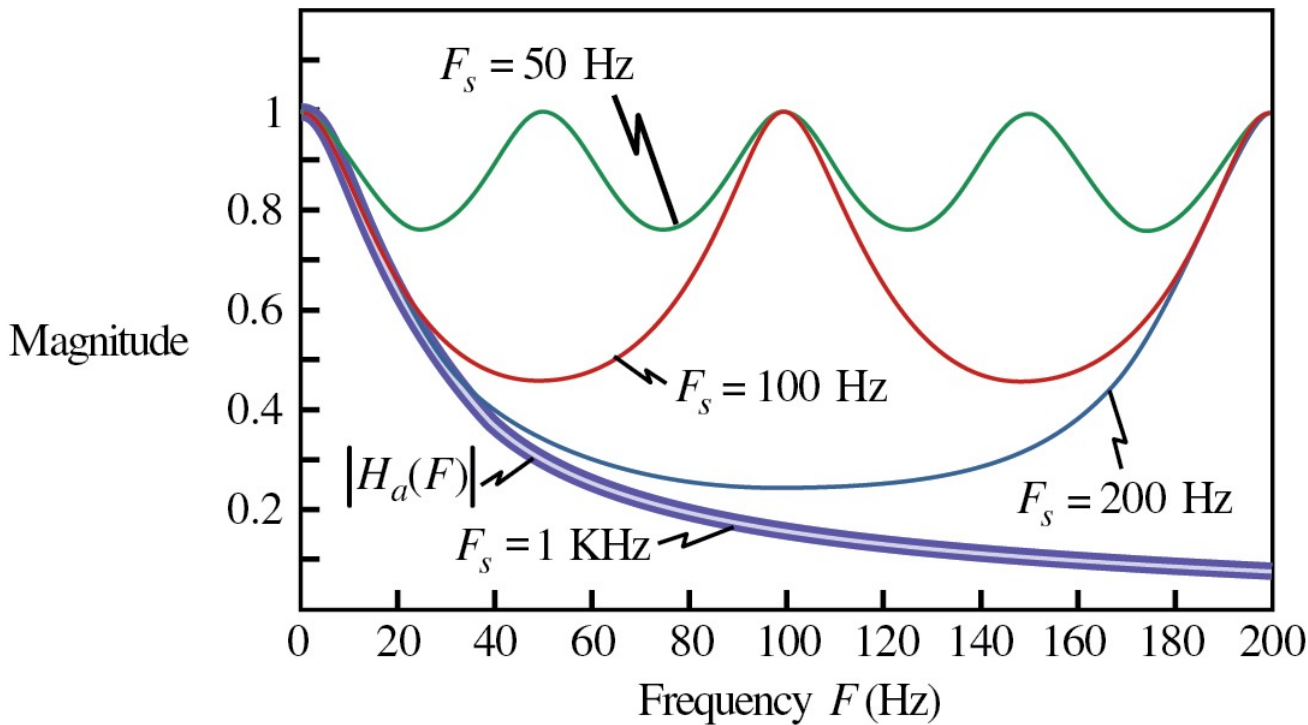
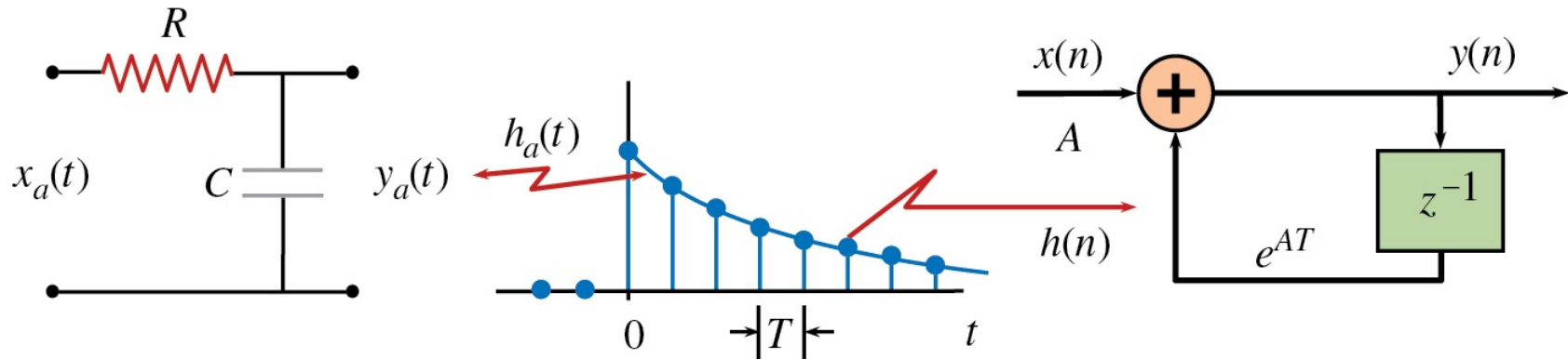

Figure 6.2.5 Frequency responses of the ideal bandlimited continuous-time differentiator (a) and its discrete-time counterpart (b).

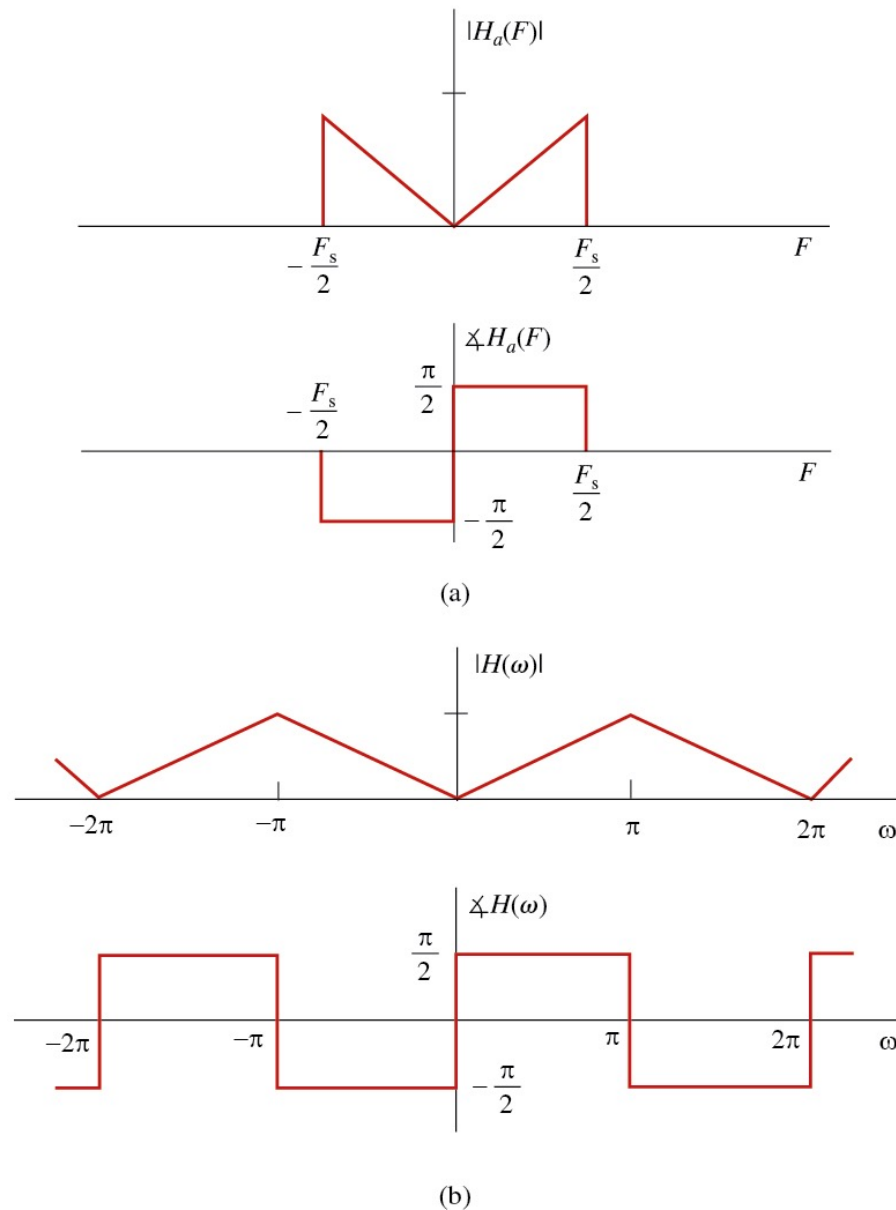

Figure 6.3.1 Illustration of bandpass signal sampling for integer band positioning.

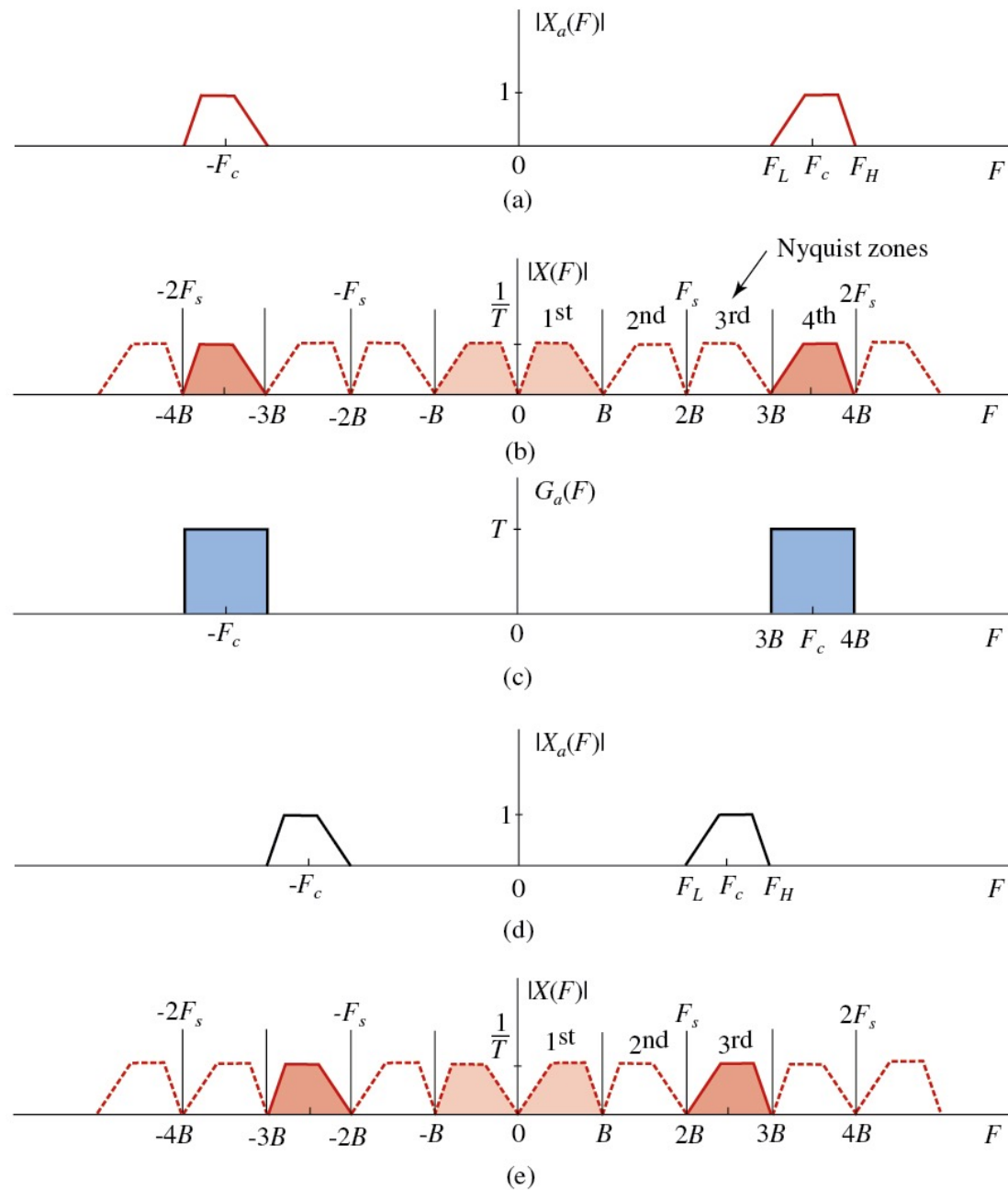

Figure 6.3.2 Illustration of bandpass signal sampling for arbitrary band positioning.

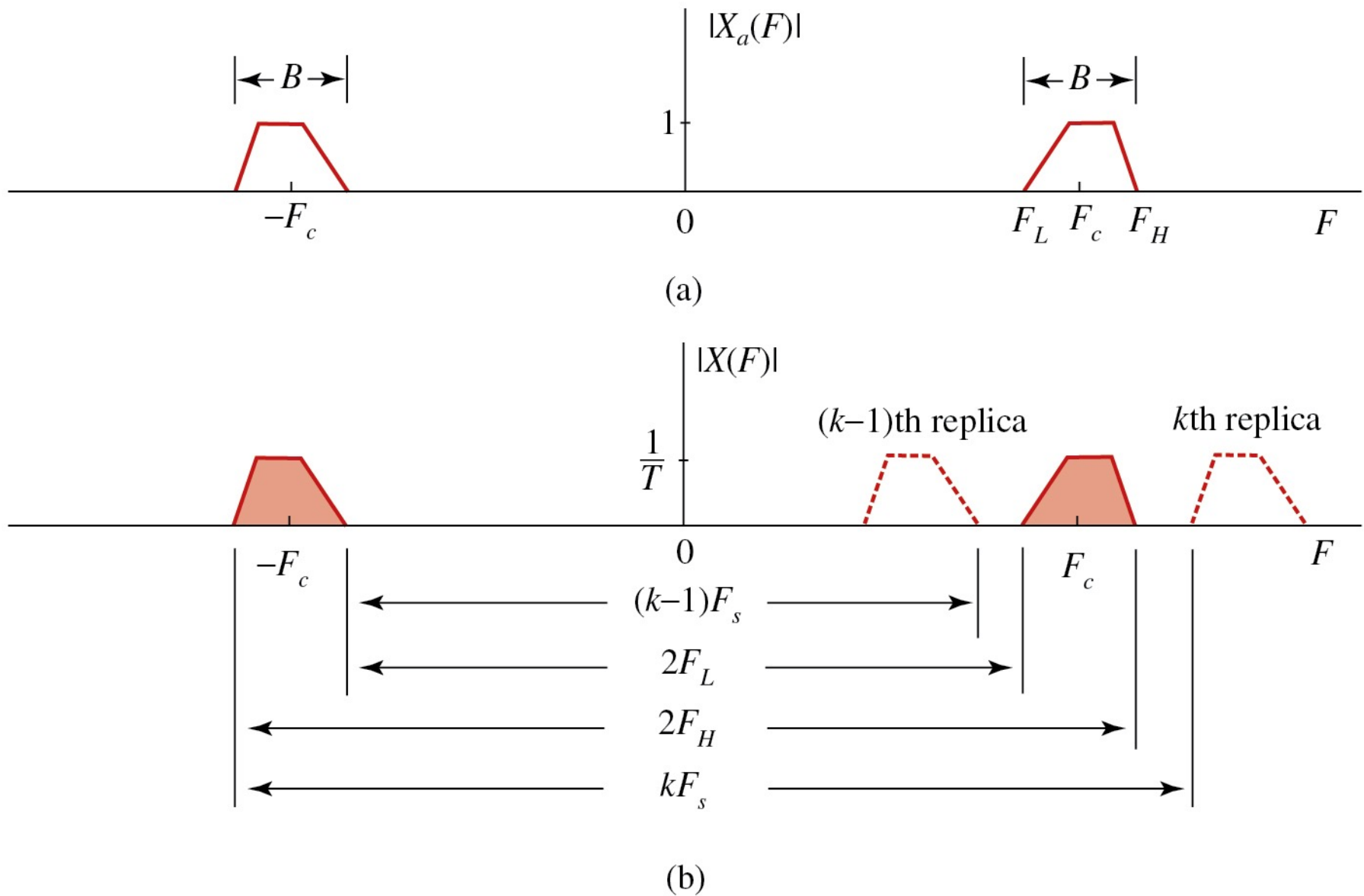

Figure 6.3.3 Allowed (white) and forbidden (shaded) sampling frequency regions for bandpass signals. The minimum sampling frequency $F_s = 2B$, which corresponds to the corners of the alias-free wedges, is possible for integerpositioned bands only.

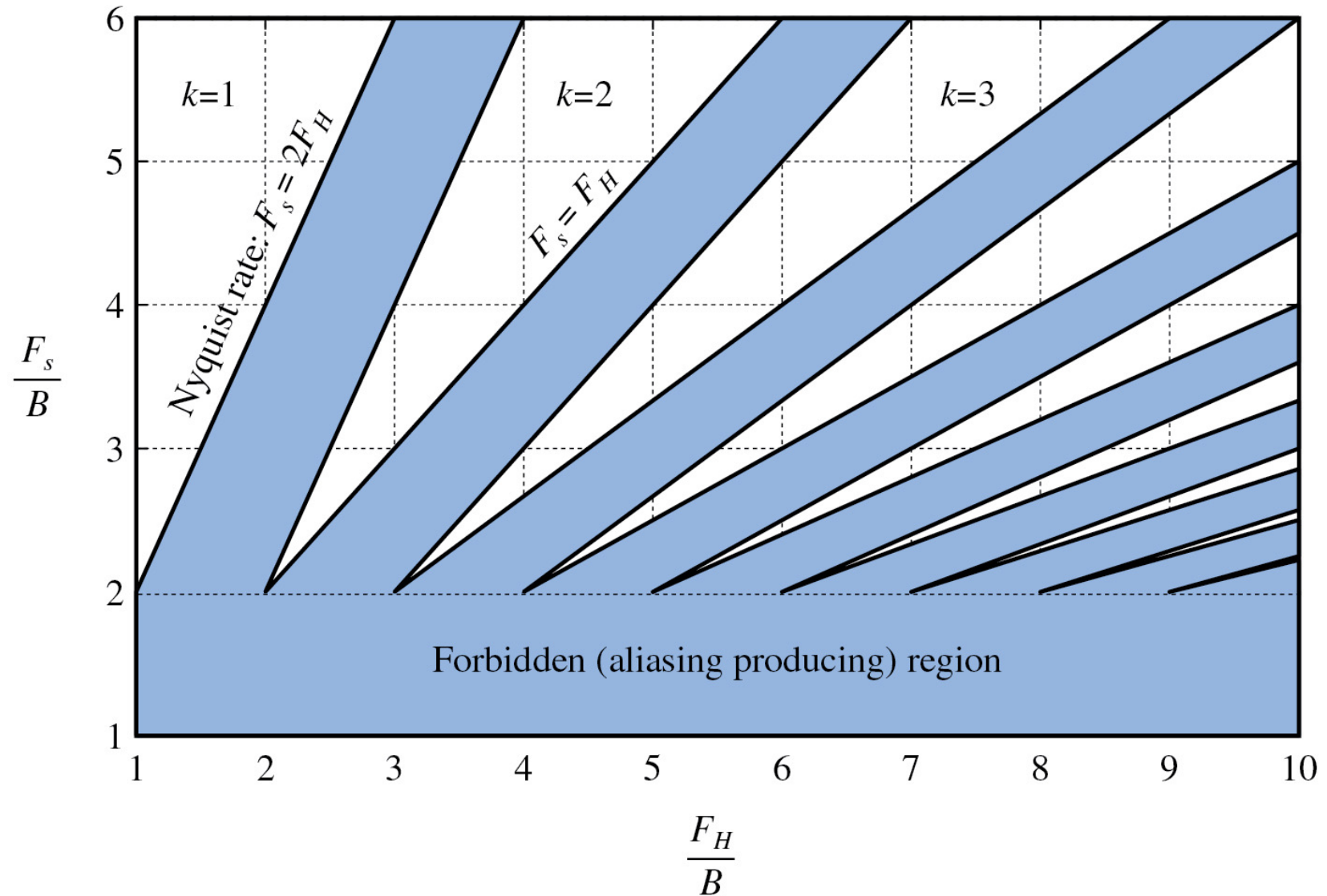

Figure 6.3.4 Illustration of the relationship between the size of guard bands and allowed sampling frequency deviations from its nominal value for the k th wedge.

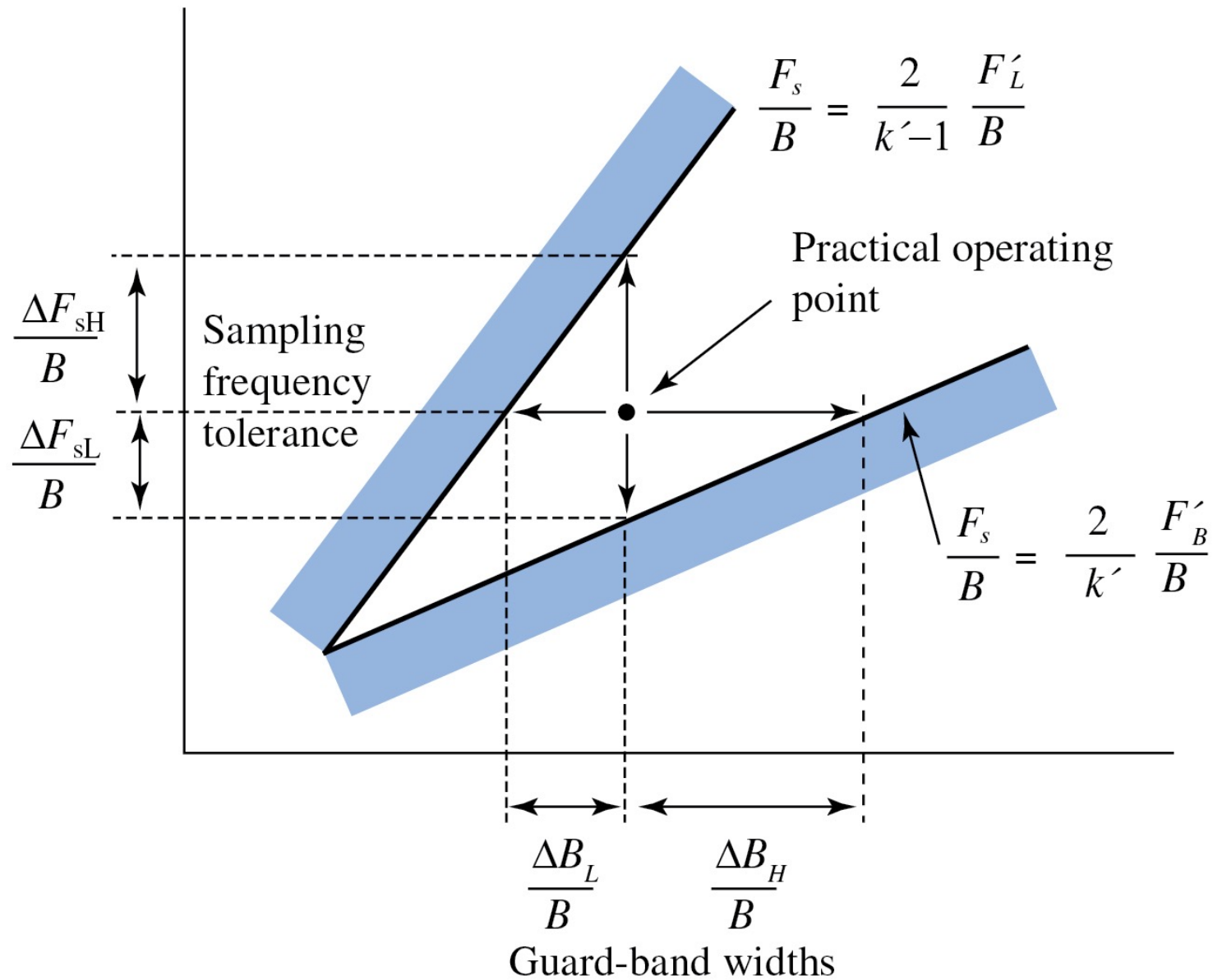
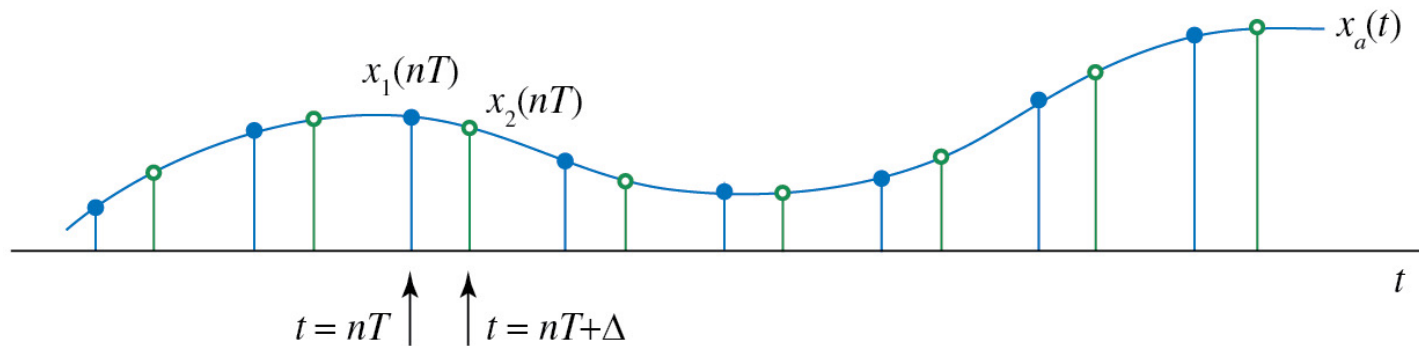
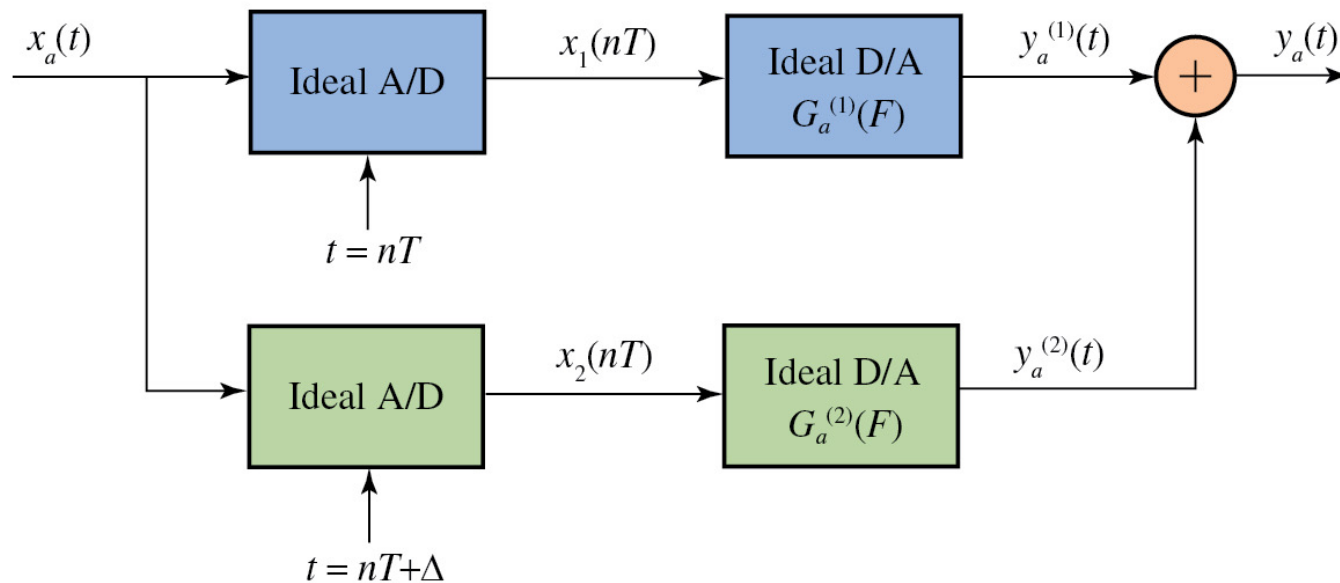

Figure 6.3.5 Illustration of second-order bandpass sampling: (a) interleaved sampled sequences, and (b) second-order sampling and reconstruction system.



(a)



(b)

Figure 6.3.6 Illustration of aliasing in second-order bandpass sampling.

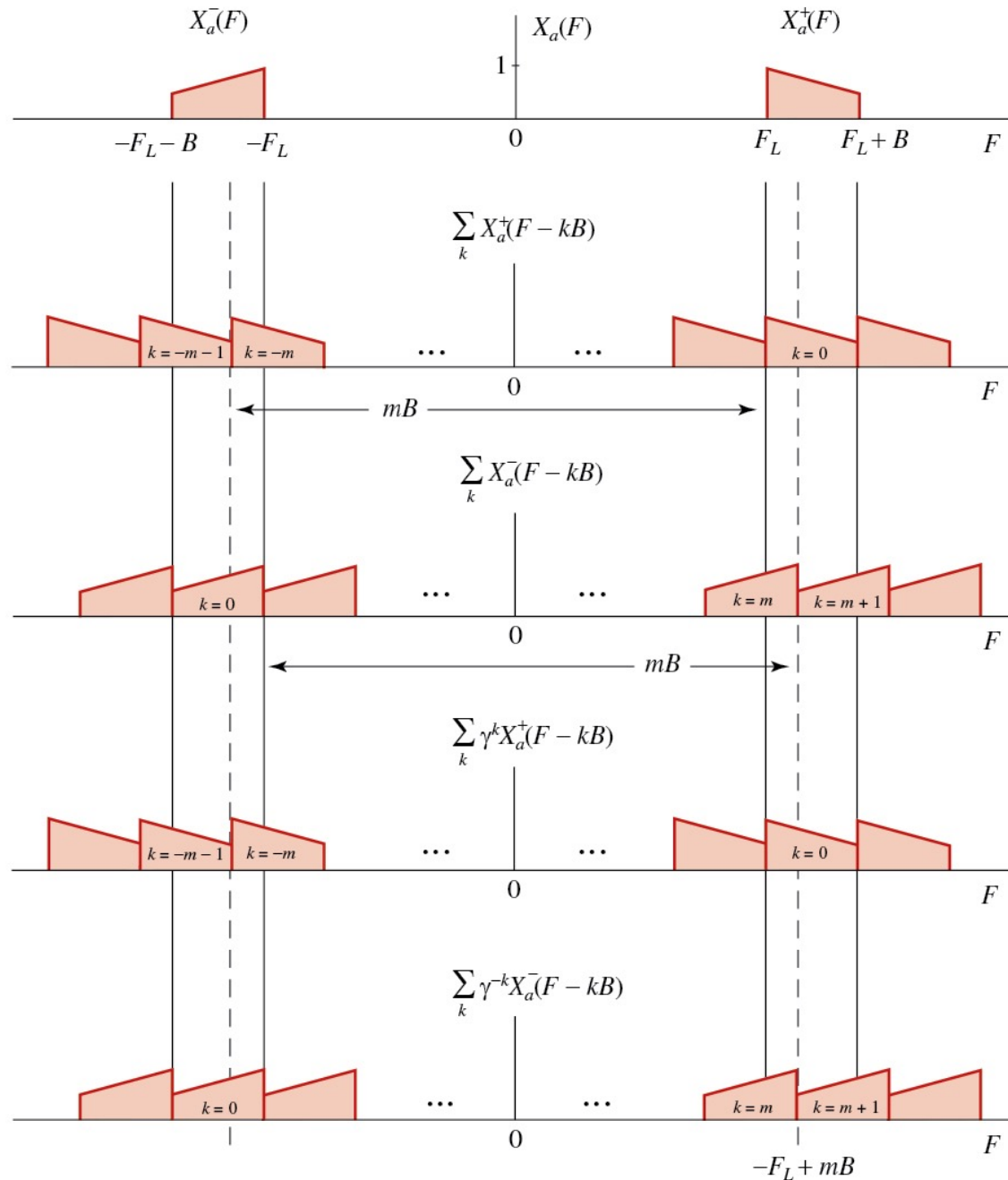

Figure 6.3.7 Frequency domain characterization of the bandpass interpolation function for second-order sampling.

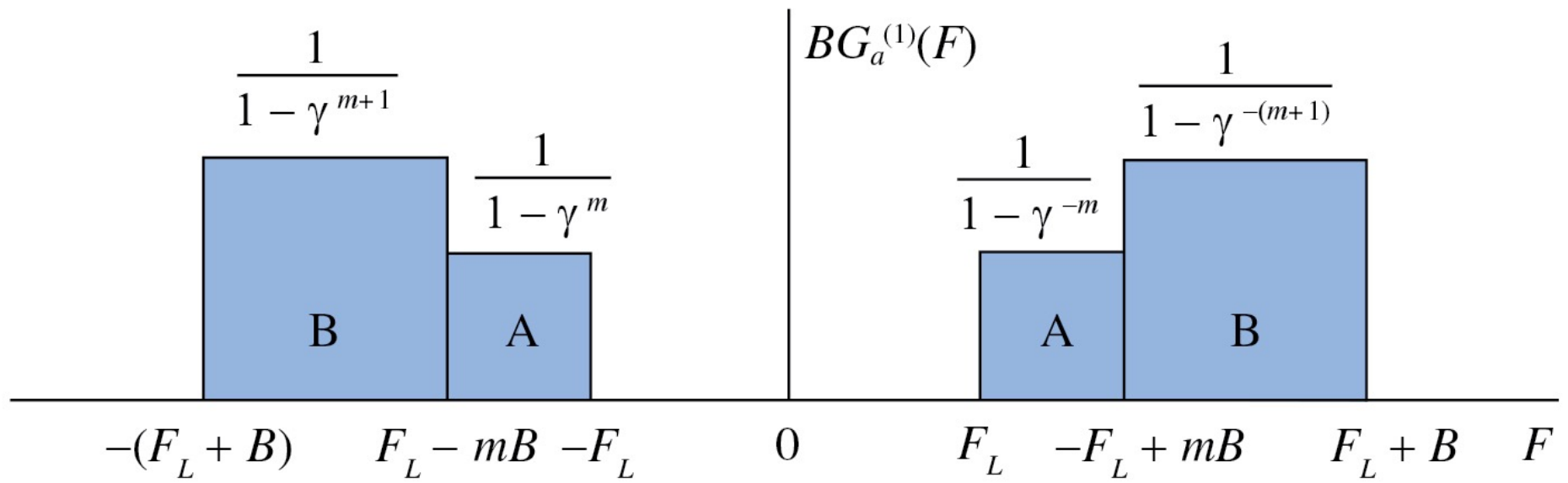

Figure 6.3.8 (a) Scheme for generating the in-phase and quadrature components of a bandpass signal. (b) Scheme for reconstructing a bandpass signal from its in-phase and quadrature components.

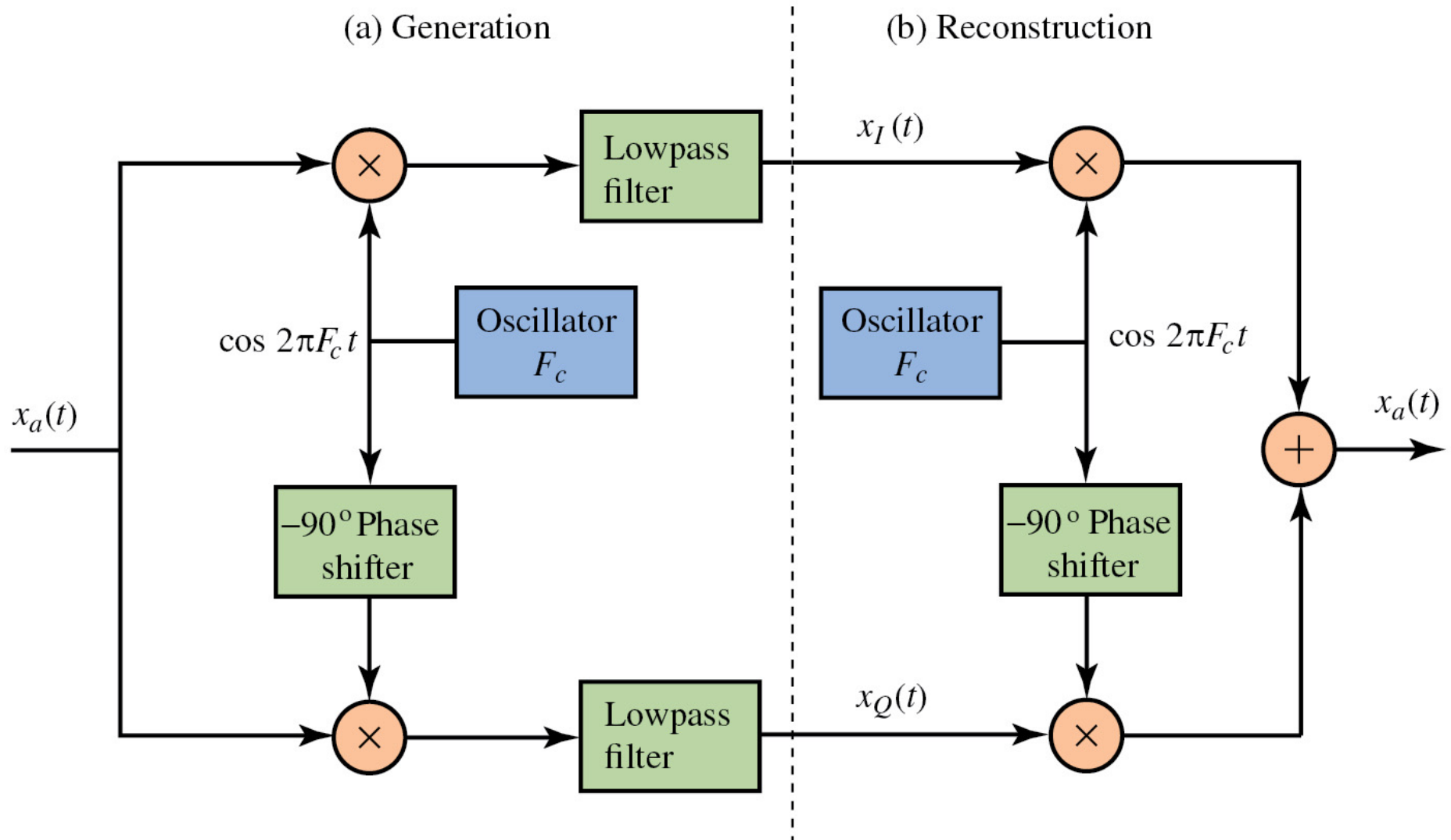

Figure 6.4.1 Illustration of discrete-time signal sampling in the frequency domain.

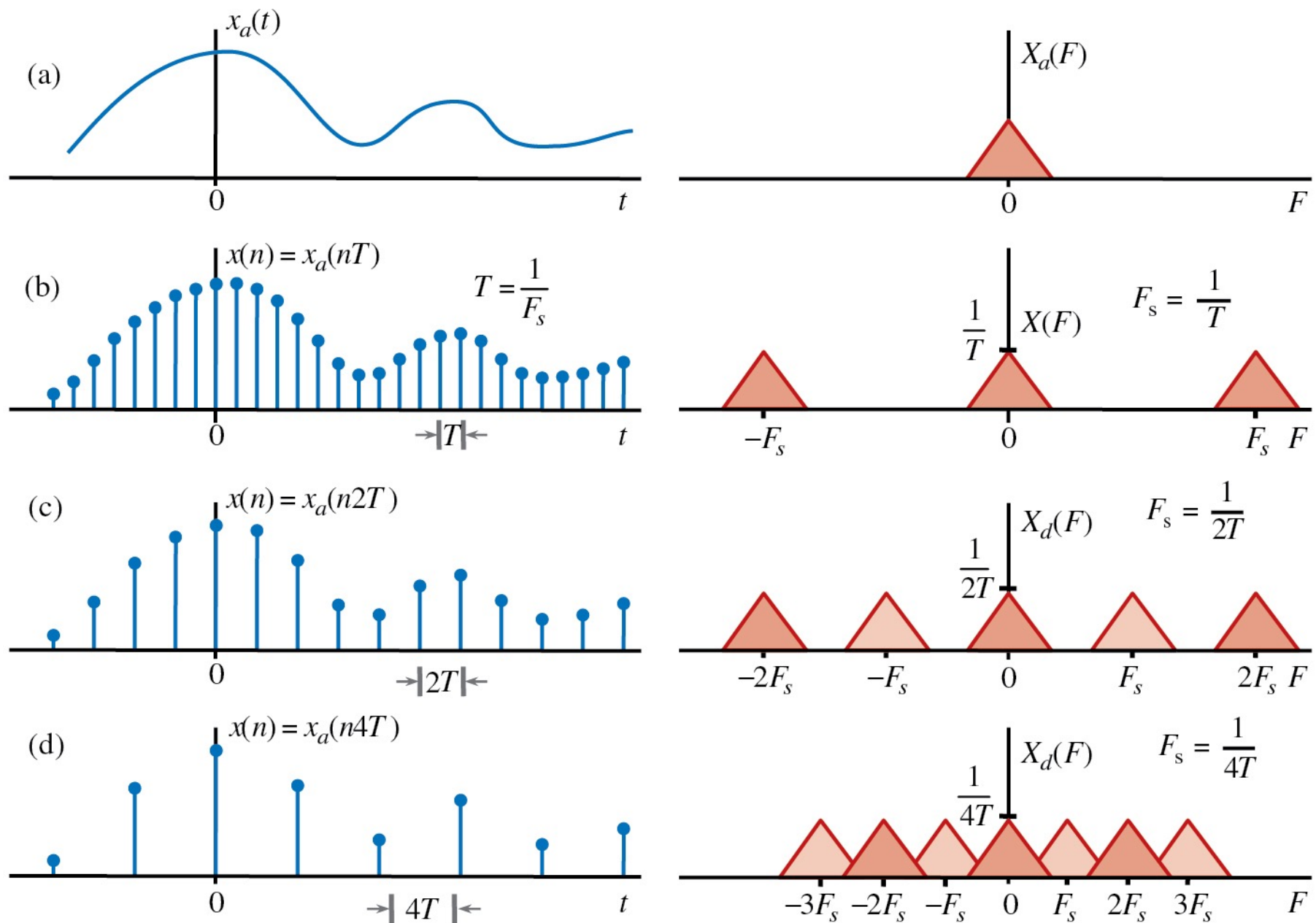

Figure 6.4.2 Illustration of continuous-time linear interpolation.

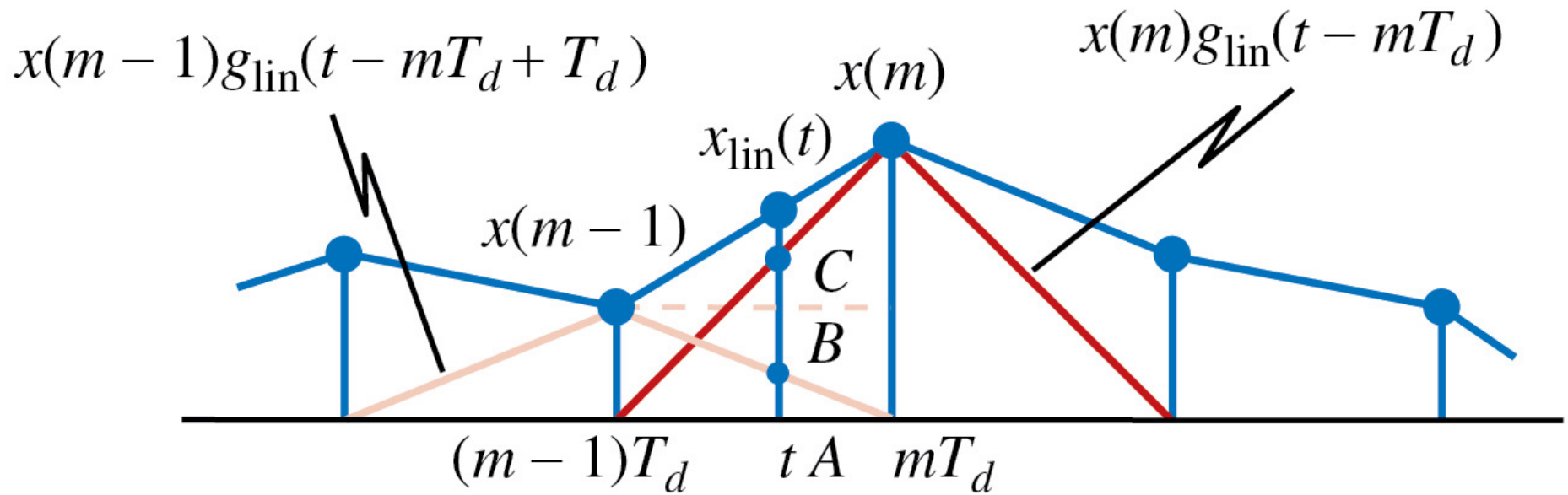

Figure 6.4.3 Frequency response of ideal and linear discrete-time interpolators.

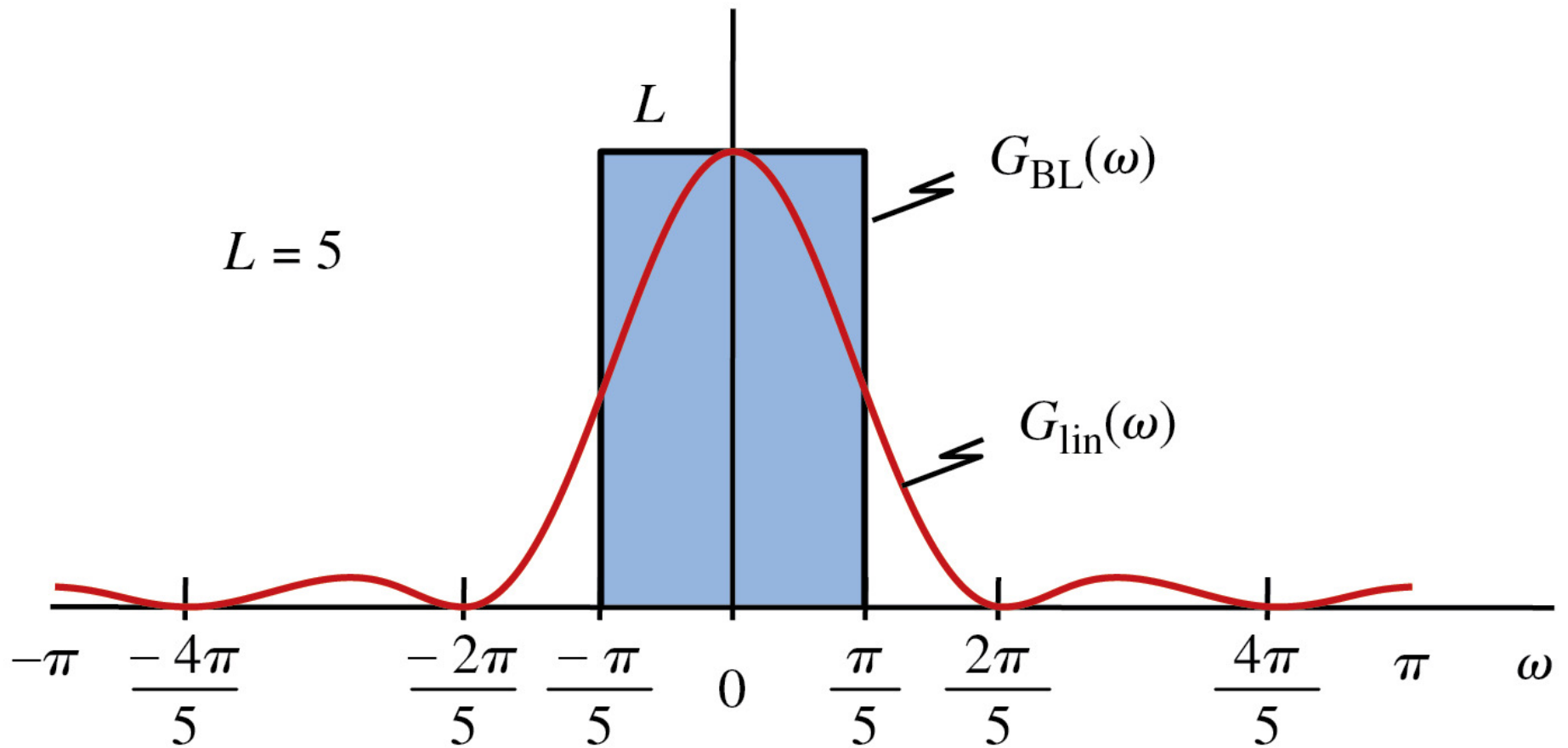

Figure 6.4.4 Illustration of linear interpolation as a linear filtering process.

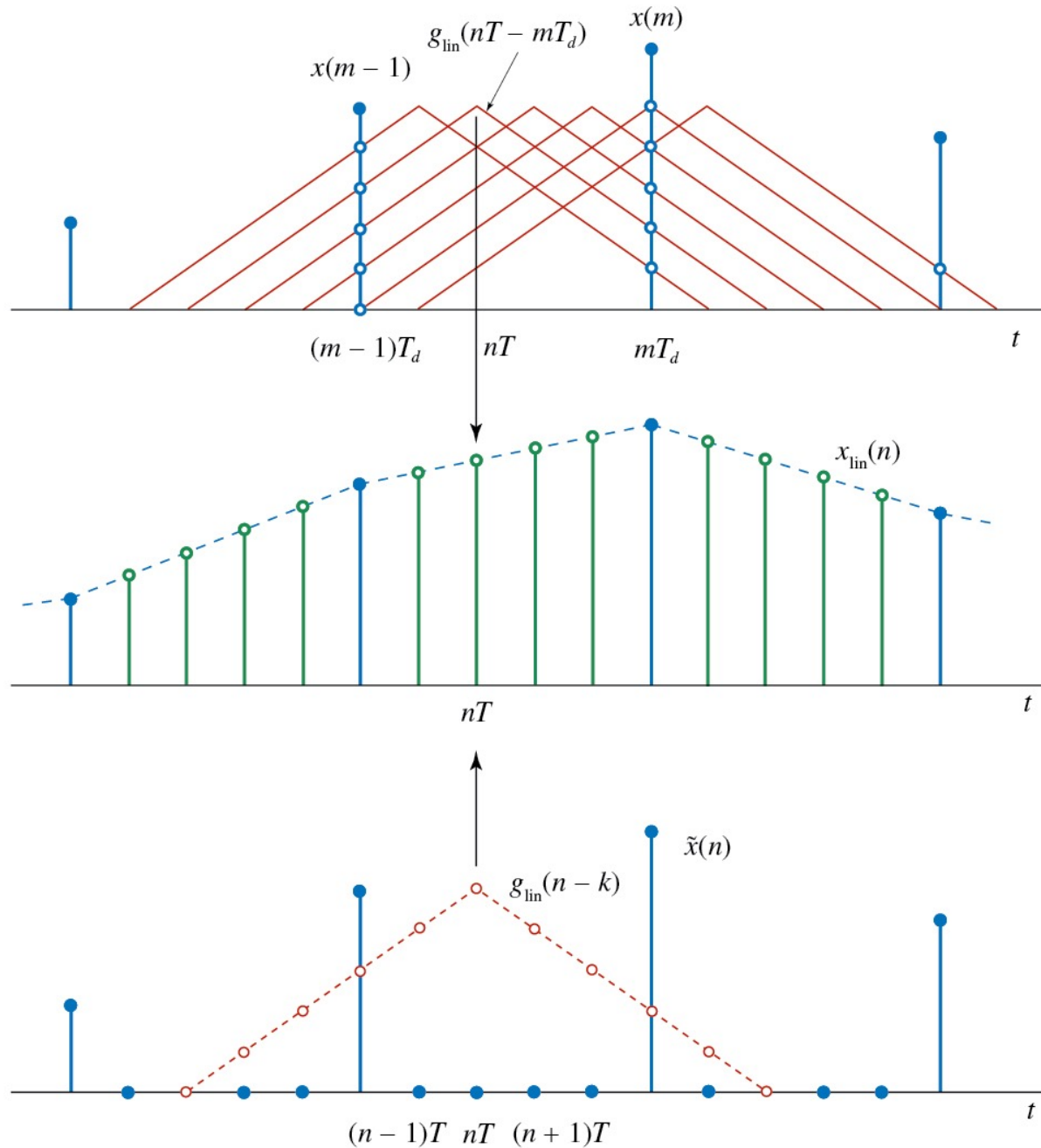

Figure 6.4.5 Impulse response (a) and frequency response (b) of the discrete-time Hilbert transformer.

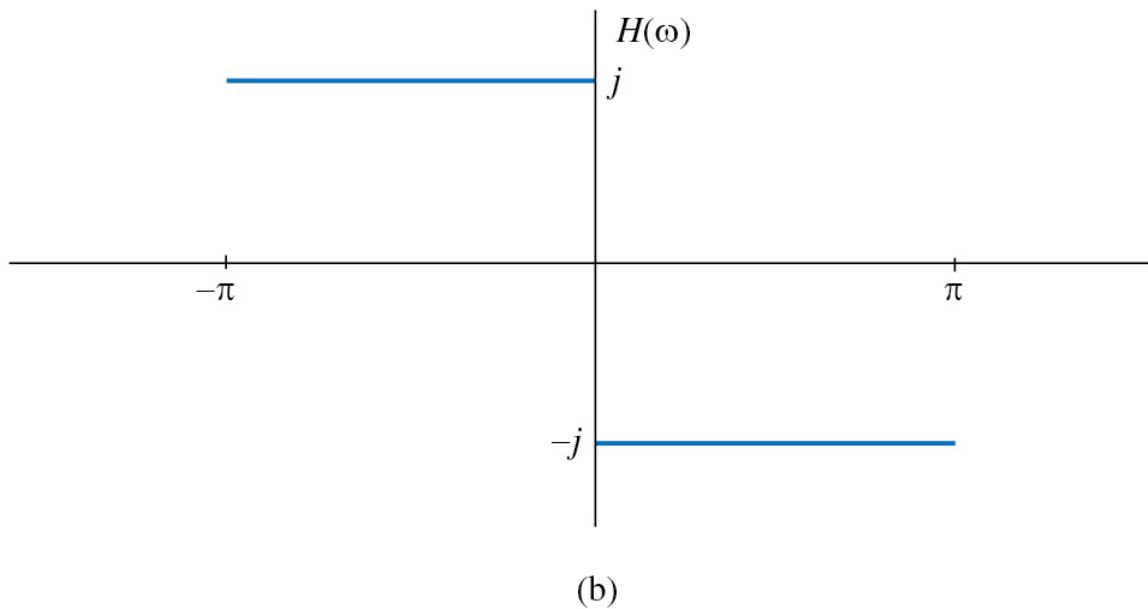
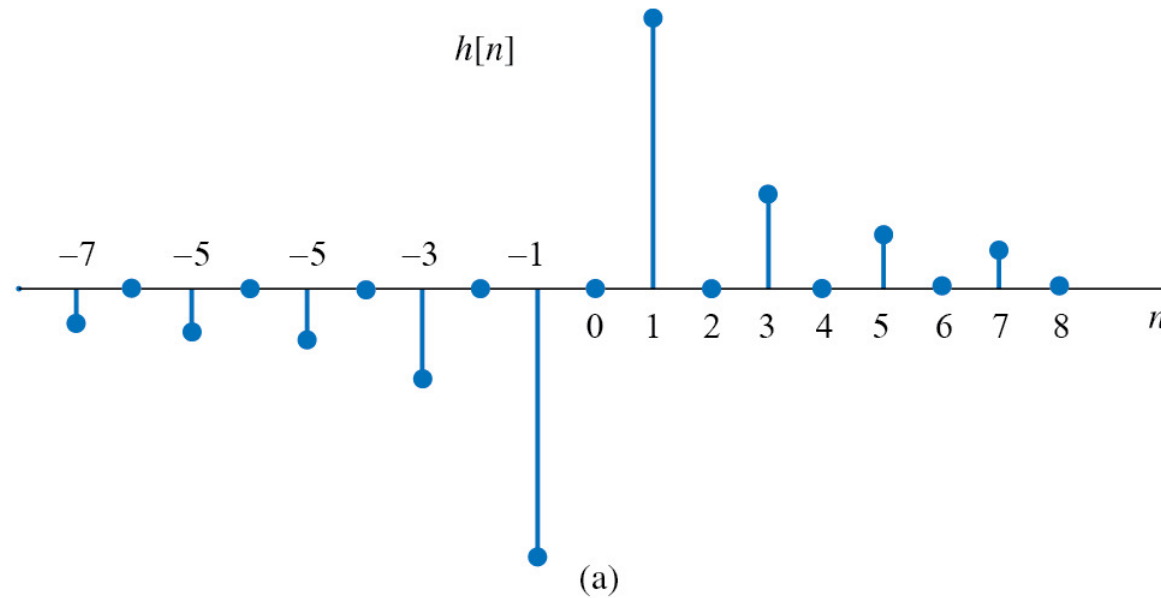
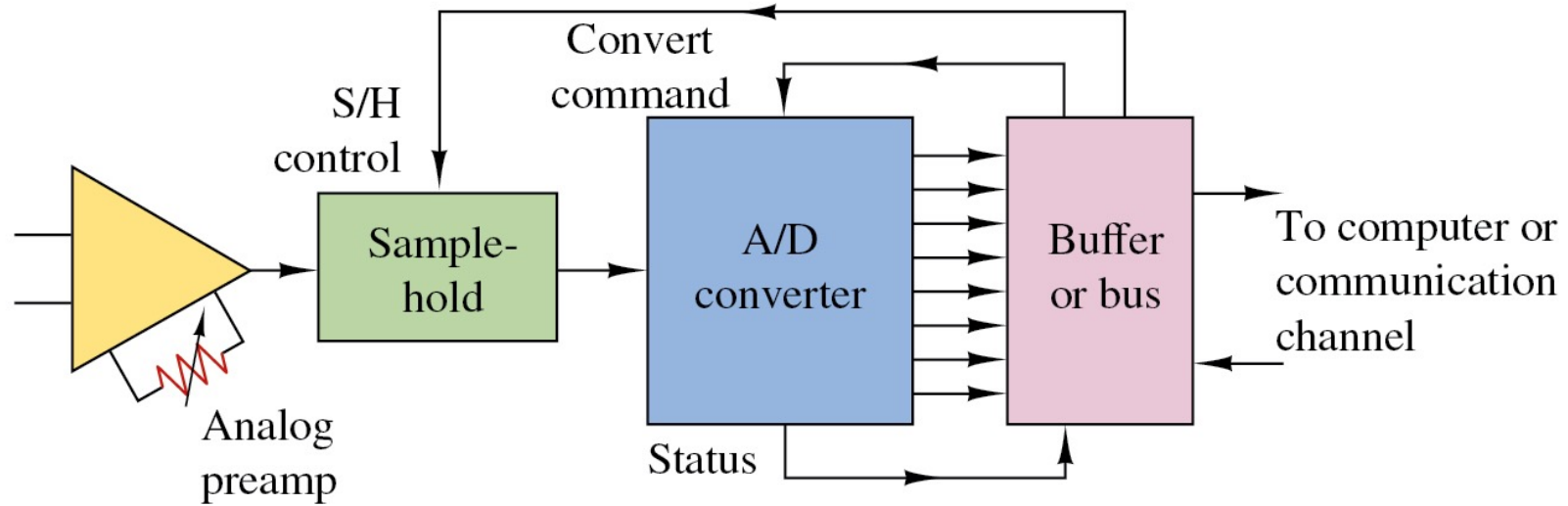
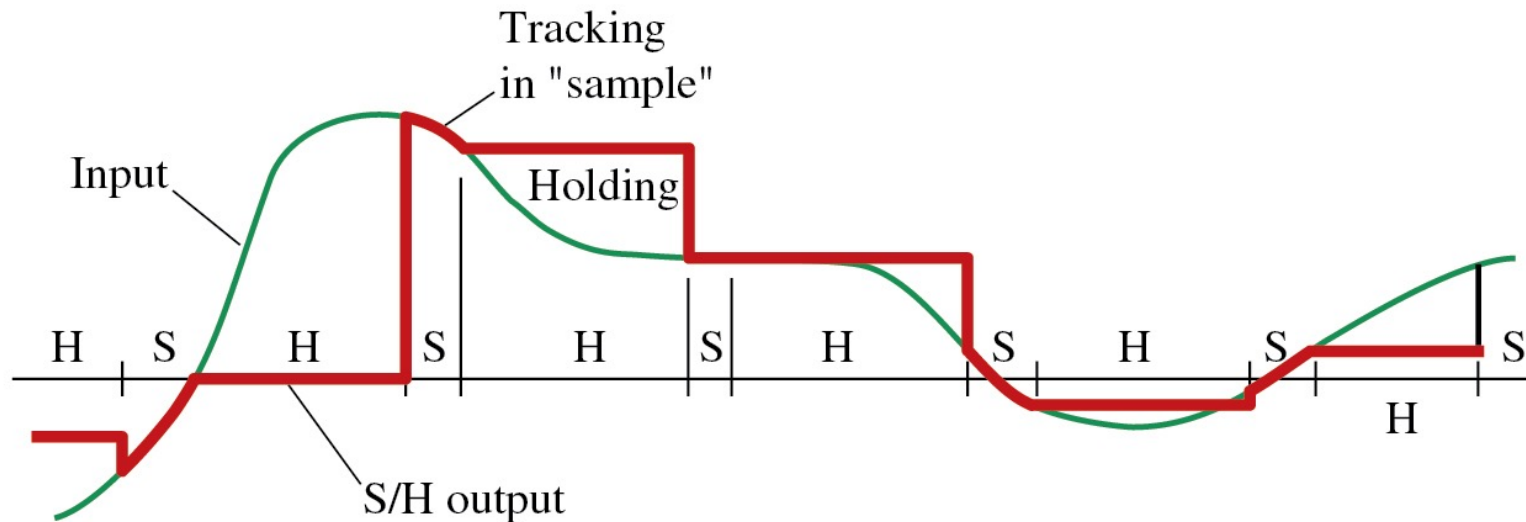

Figure 6.5.1 (a) Block diagram of basic elements of an A/D converter; (b) time-domain response of an ideal S/H circuit.



(a)



(b)

Figure 6.5.2 Quantization process and an example of a midtread quantizer.

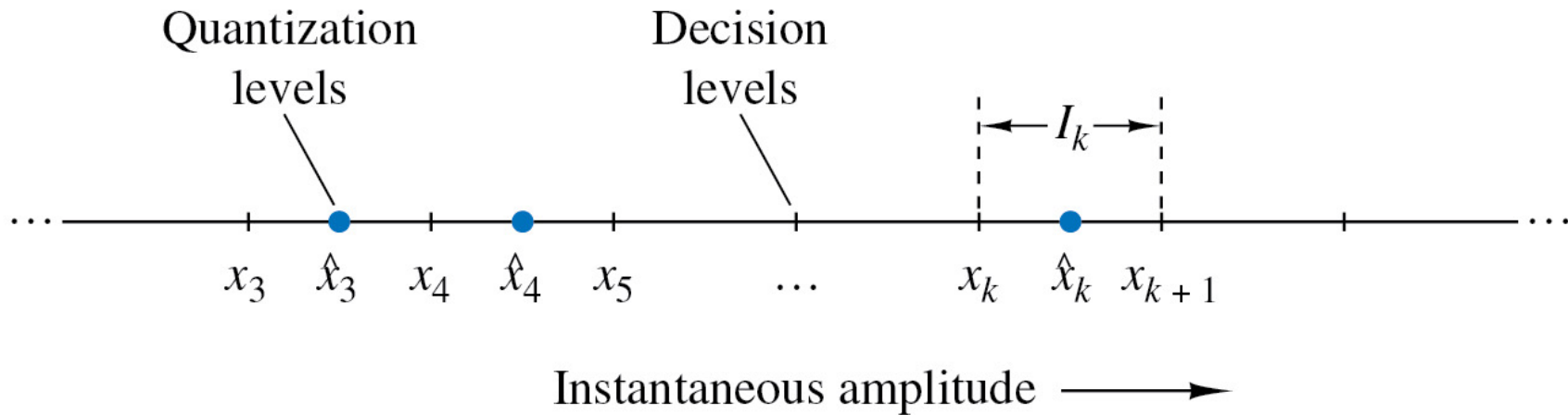

(a)

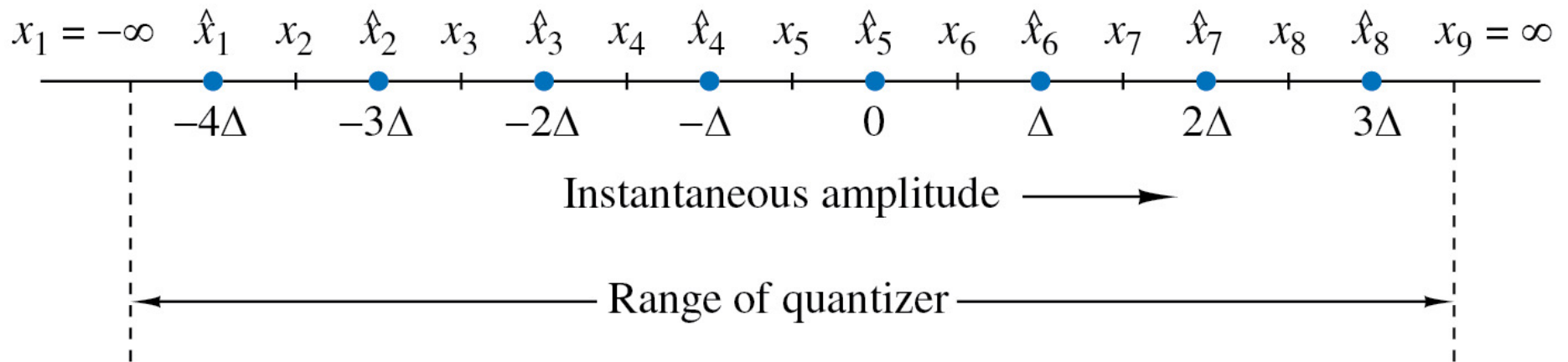

(b)

Figure 6.5.3 Example of a midread quantizer.

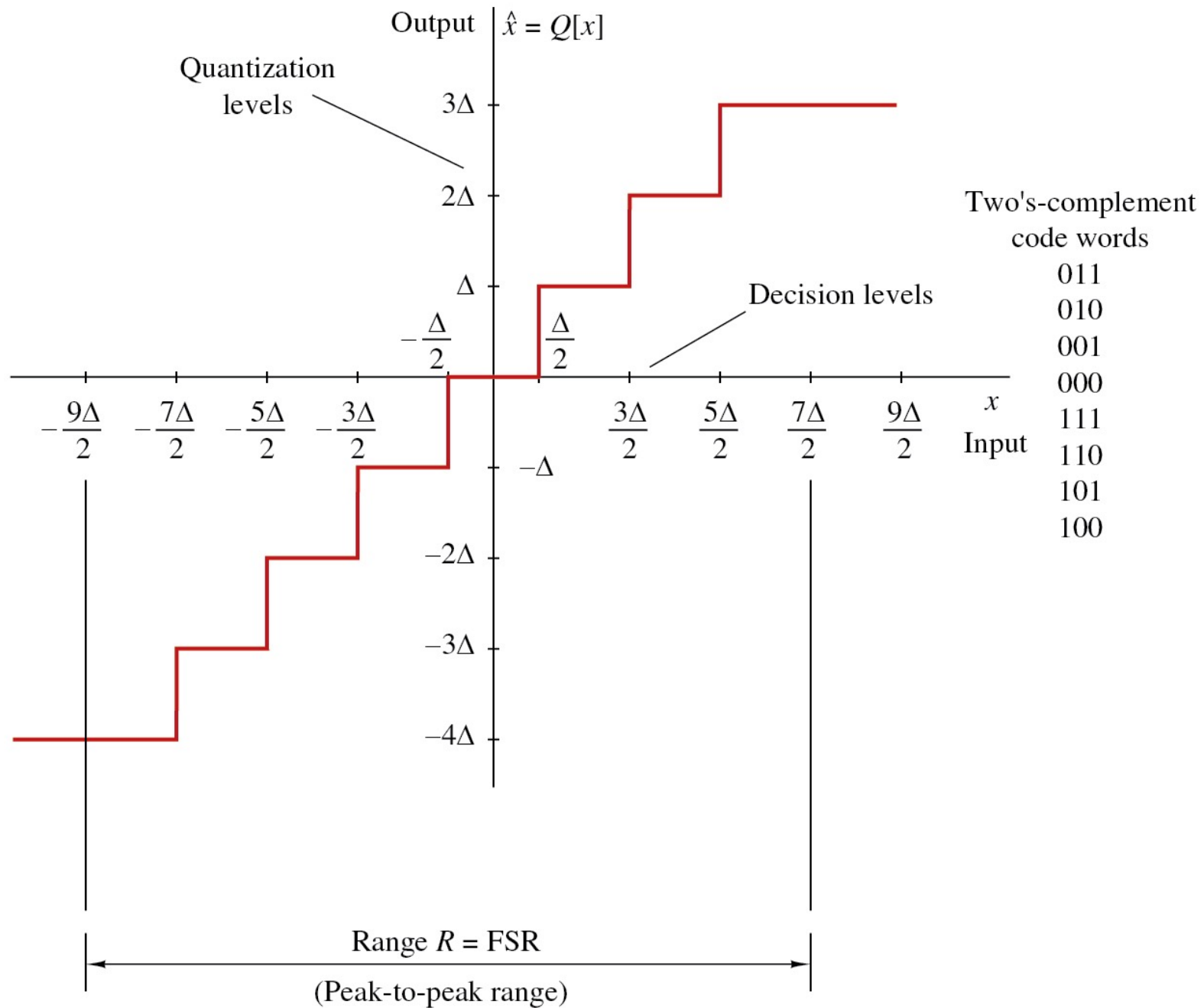
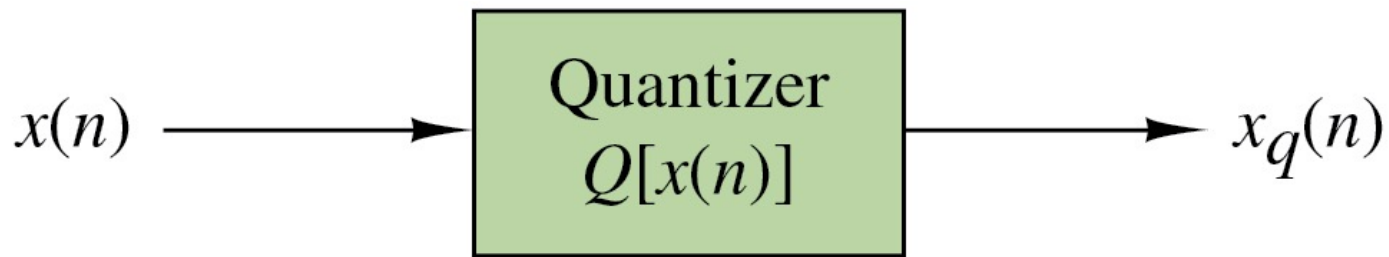

Table 6.1 Commonly Used Bipolar Codes

| Number | Decimal Fraction | | Sign + Magnitude | Two's Complement | Offset Binary | One's Complement |
|--------|-----------------------|-----------------------|---------------------|---------------------|------------------|---------------------|
| | Positive Reference | Negative Reference | | | | |
| +7 | $+\frac{7}{8}$ | $-\frac{7}{8}$ | 0111 | 0111 | 1111 | 0111 |
| +6 | $+\frac{6}{8}$ | $-\frac{6}{8}$ | 0110 | 0110 | 1110 | 0110 |
| +5 | $+\frac{5}{8}$ | $-\frac{5}{8}$ | 0101 | 0101 | 1101 | 0101 |
| +4 | $+\frac{4}{8}$ | $-\frac{4}{8}$ | 0100 | 0100 | 1100 | 0100 |
| +3 | $+\frac{3}{8}$ | $-\frac{3}{8}$ | 0011 | 0011 | 1011 | 0011 |
| +2 | $+\frac{2}{8}$ | $-\frac{2}{8}$ | 0010 | 0010 | 1010 | 0010 |
| +1 | $+\frac{1}{8}$ | $-\frac{1}{8}$ | 0001 | 0001 | 1001 | 0001 |
| 0 | 0+ | 0- | 0000 | 0000 | 1000 | 0000 |
| 0 | 0- | 0+ | 1000 | (0000) | (1000) | 1111 |
| -1 | $-\frac{1}{8}$ | $+\frac{1}{8}$ | 1001 | 1111 | 0111 | 1110 |
| -2 | $-\frac{2}{8}$ | $+\frac{2}{8}$ | 1010 | 1110 | 0110 | 1101 |
| -3 | $-\frac{3}{8}$ | $+\frac{3}{8}$ | 1011 | 1101 | 0101 | 1100 |
| -4 | $-\frac{4}{8}$ | $+\frac{4}{8}$ | 1100 | 1100 | 0100 | 1011 |
| -5 | $-\frac{5}{8}$ | $+\frac{5}{8}$ | 1101 | 1011 | 0011 | 1010 |
| -6 | $-\frac{6}{8}$ | $+\frac{6}{8}$ | 1110 | 1010 | 0010 | 1001 |
| -7 | $-\frac{7}{8}$ | $+\frac{7}{8}$ | 1111 | 1001 | 0001 | 1000 |
| -8 | $-\frac{8}{8}$ | $+\frac{8}{8}$ | | (1000) | (0000) | |

Figure 6.5.4 Mathematical model of quantization noise.



(a) Actual system

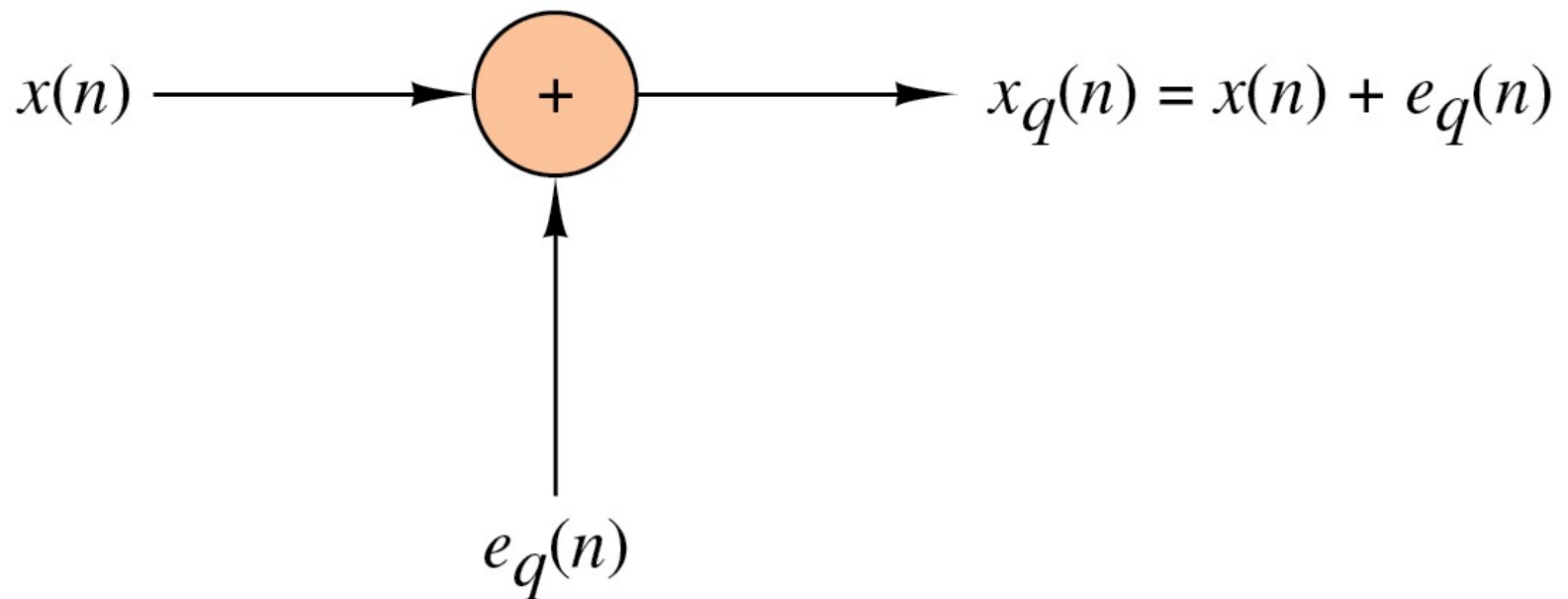

(b) Mathematical model

Figure 6.5.5 Probability density function for the quantization error.

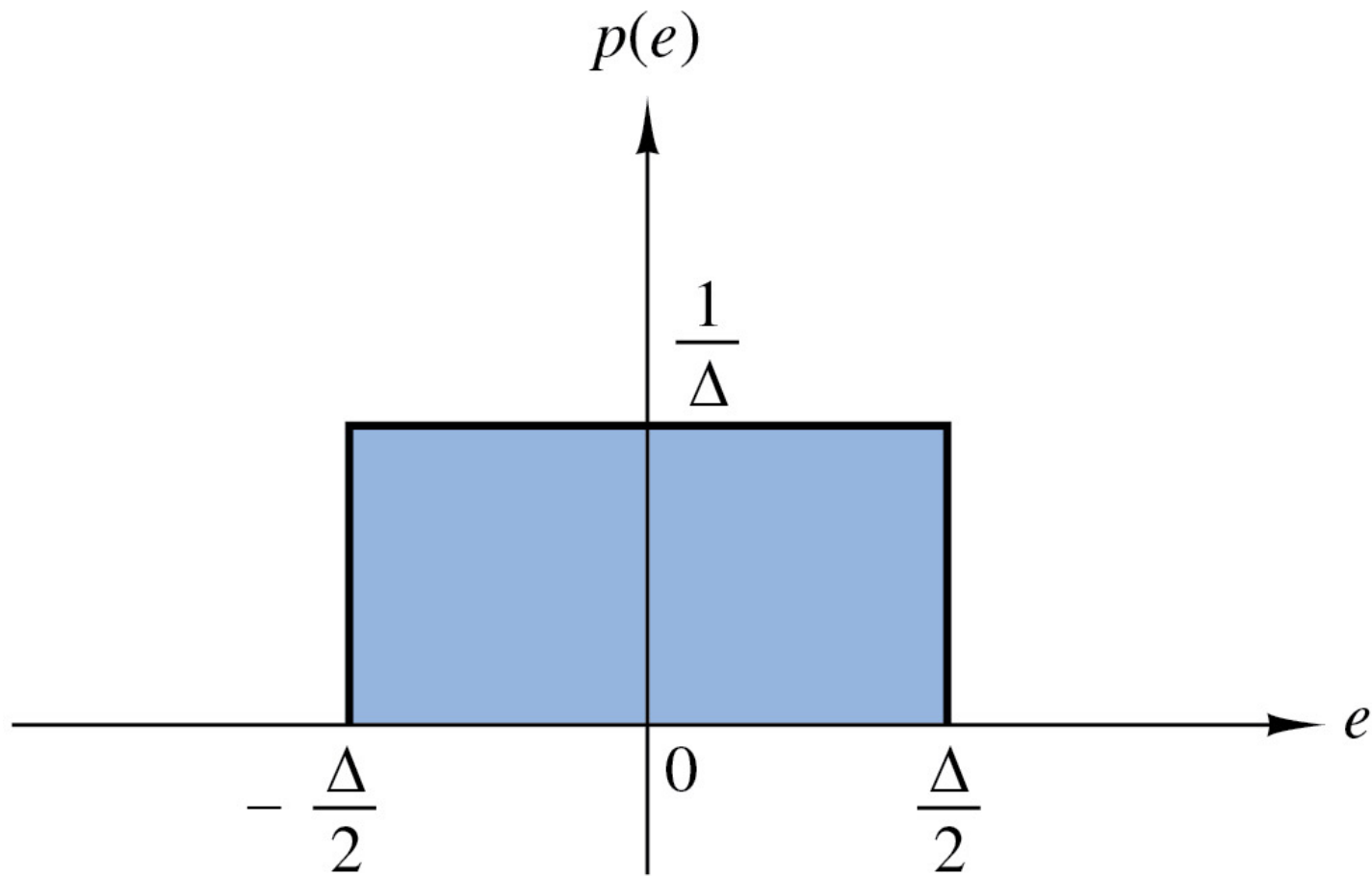

Figure 6.5.6 Basic operations in converting a digital signal into an analog signal.

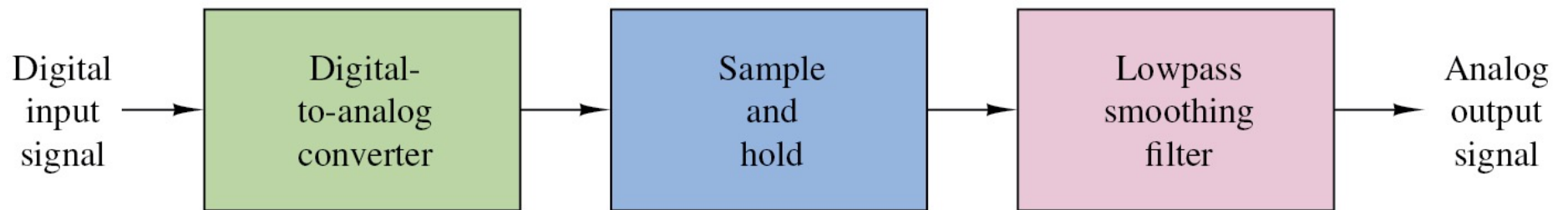

Figure 6.5.7 Ideal D/A converter characteristic.

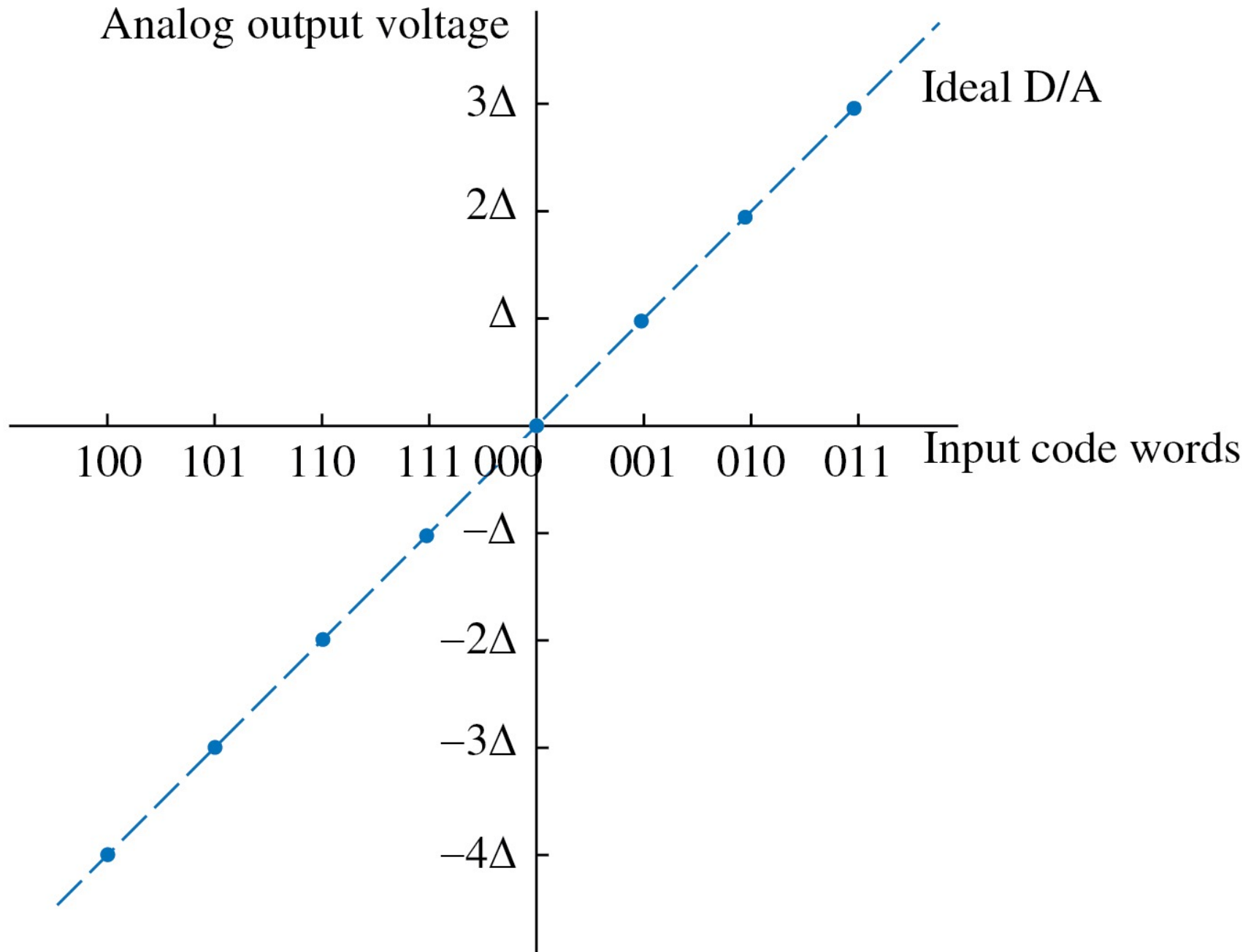

Figure 6.5.8 Response of an S/H interpolator to a discrete-time sinusoidal signal.

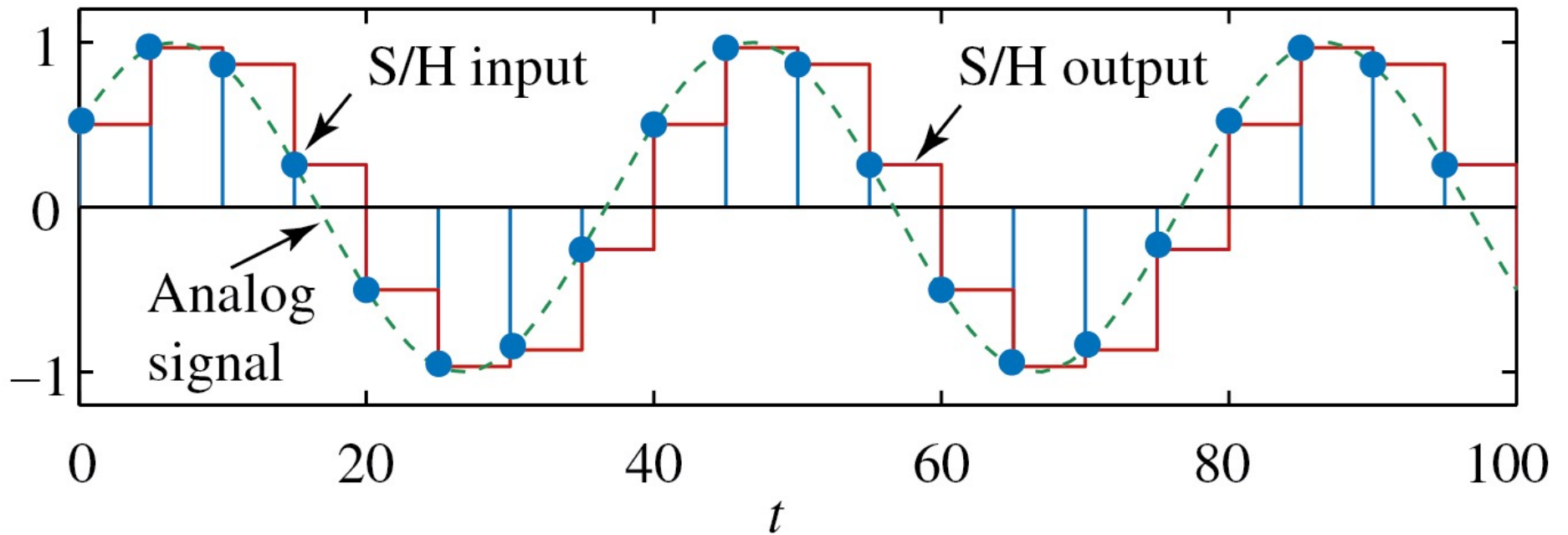

Figure 6.5.9 Frequency responses of sample-and-hold and the ideal bandlimited interpolator.

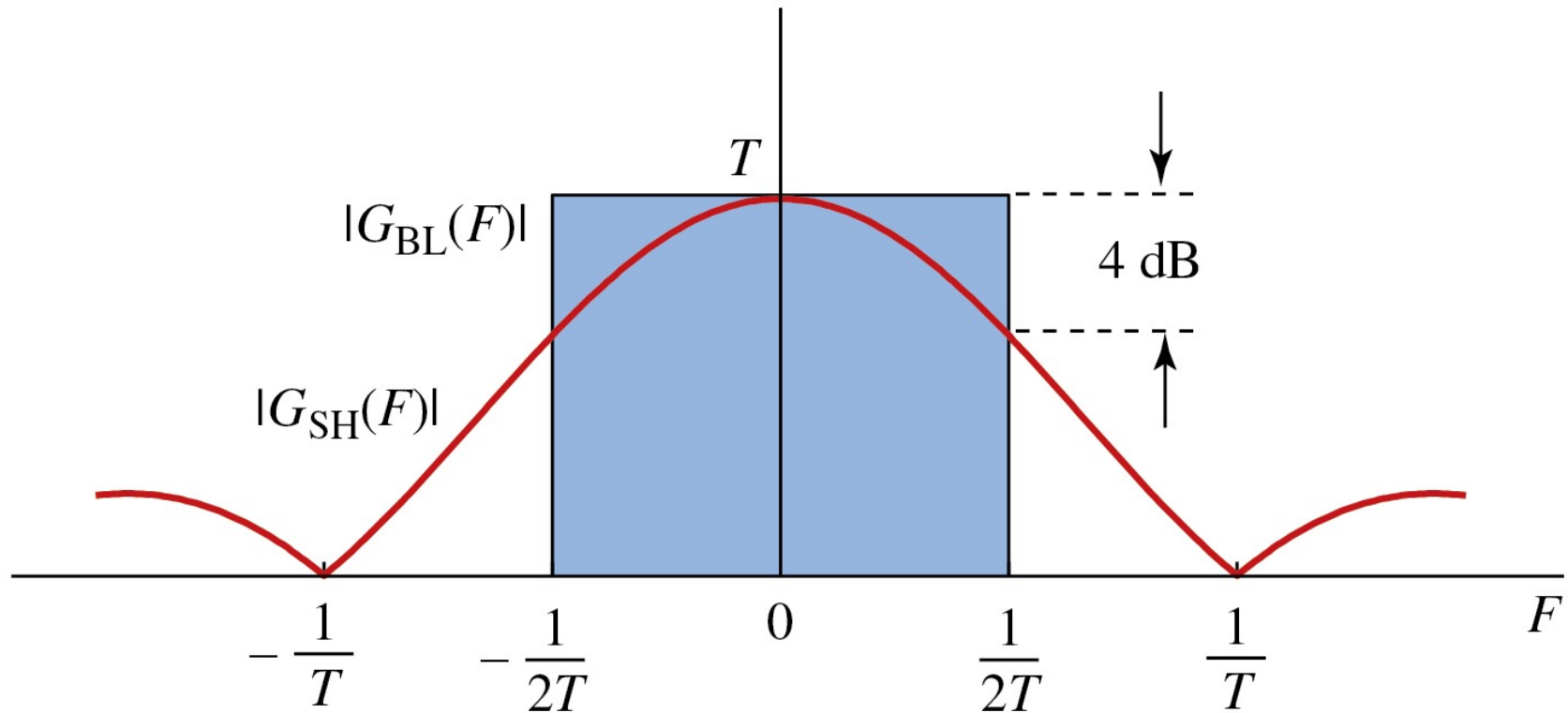

Figure 6.6.1 Encoder and decoder for differential predictive signal quantizer system.

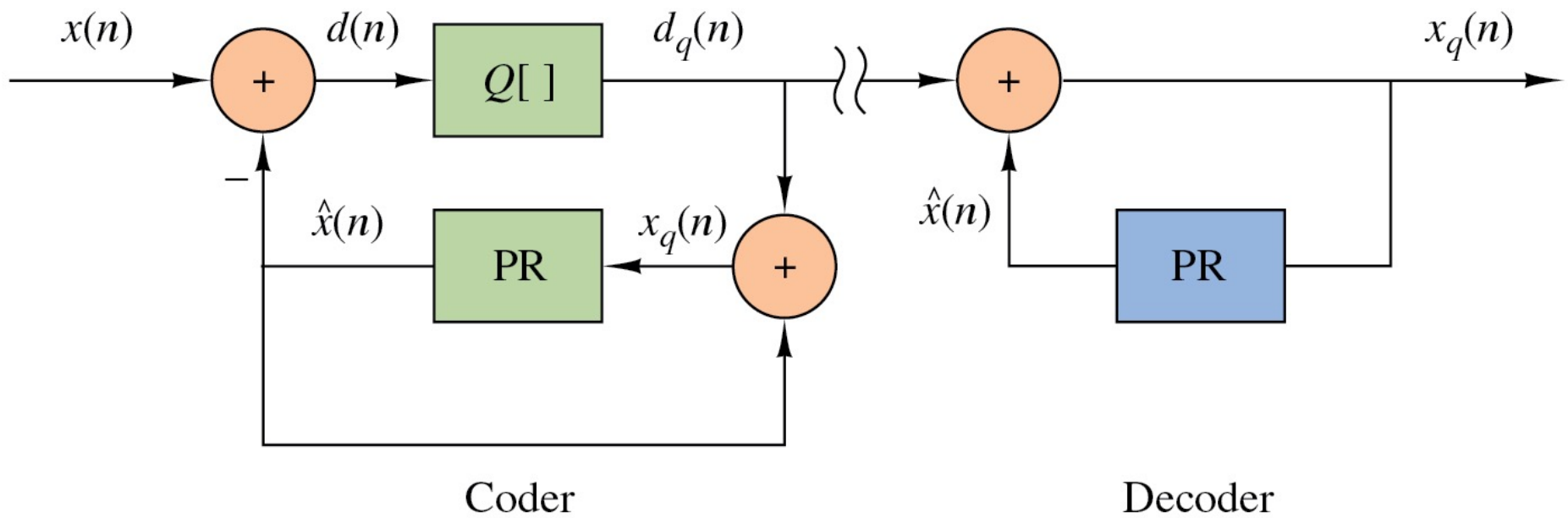
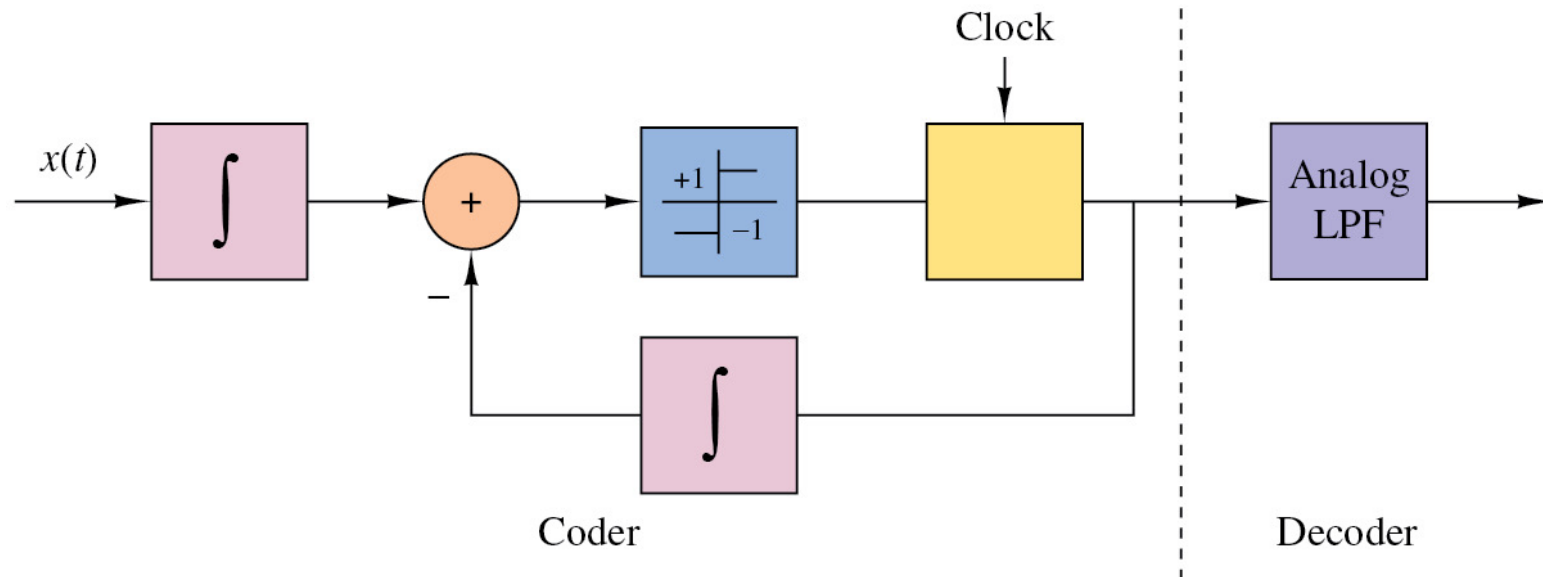
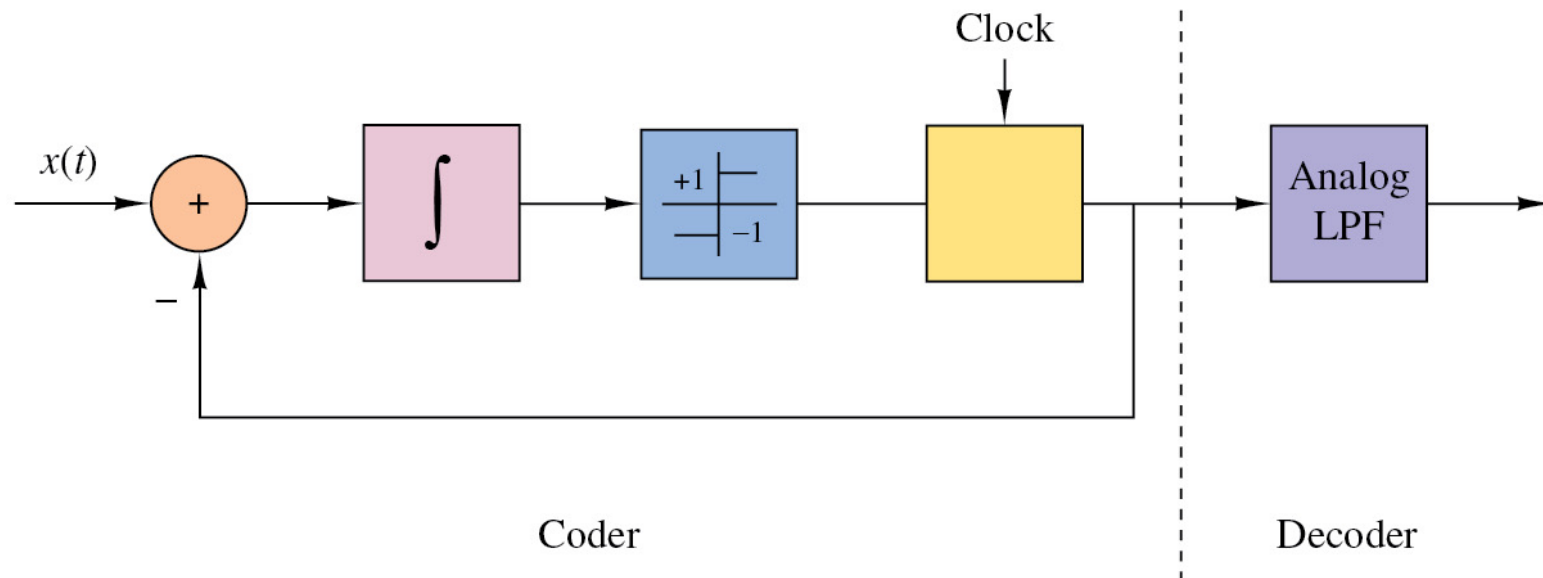

Figure 6.6.3 Sigma-delta modulation system.



(a)



(b)

Figure 6.6.4 Discrete-time model of sigma-delta modulation.

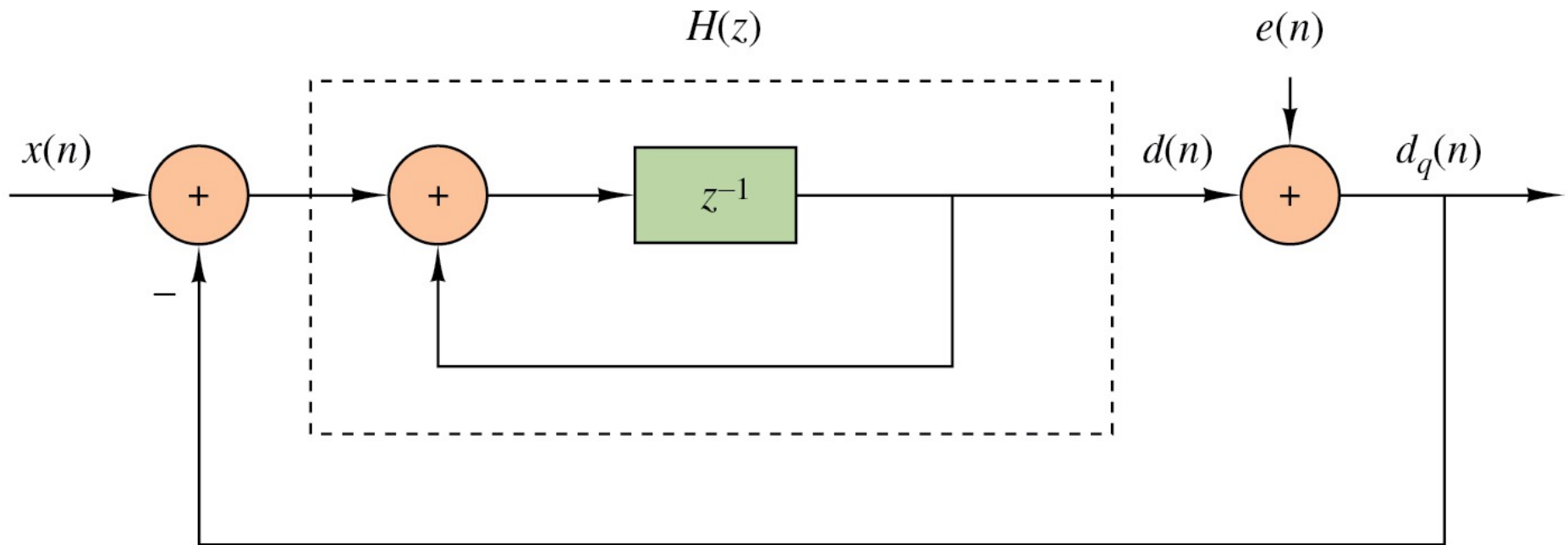

Figure 6.6.5 Frequency (magnitude) response of noise system function.

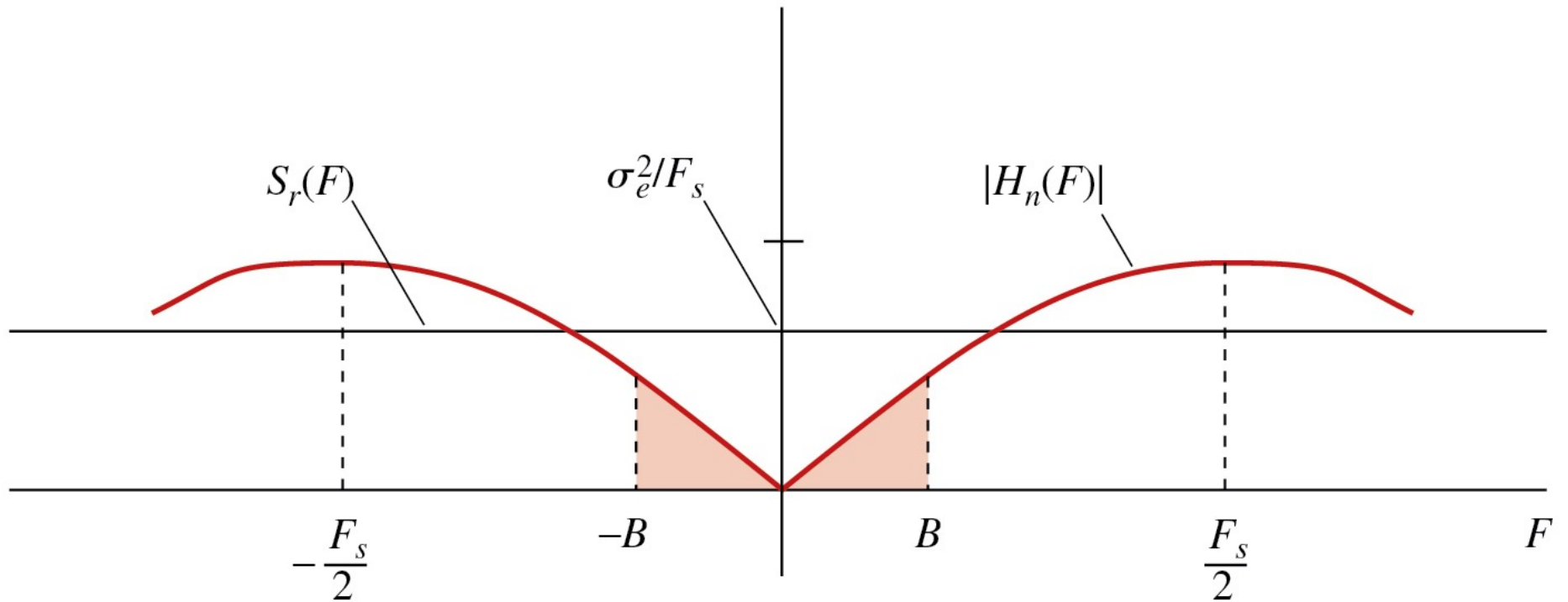

Figure 6.6.6 Basic elements of an oversampling A/D converter.

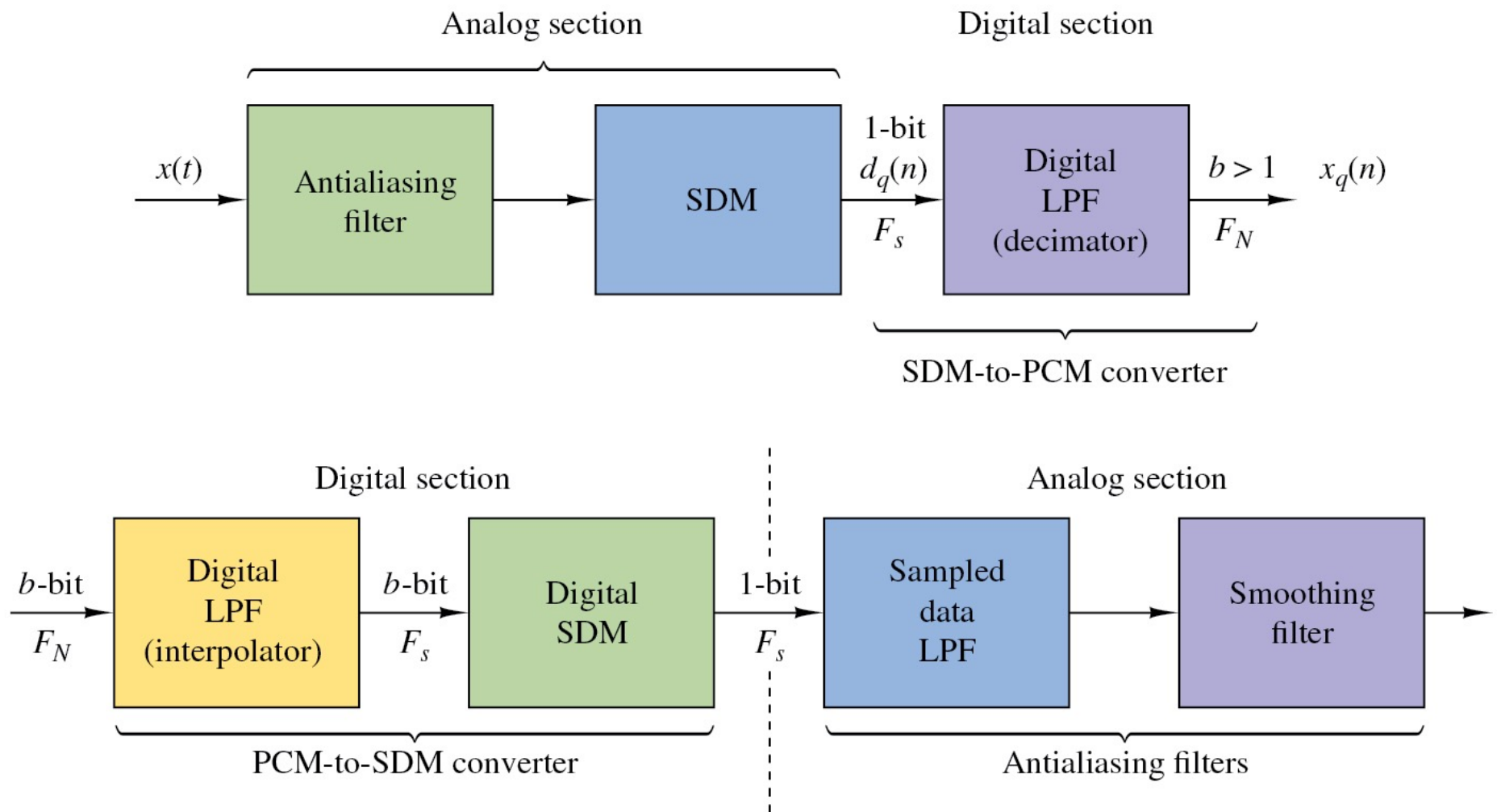

Figure 6.6.7 Elements of an oversampling D/A converter.

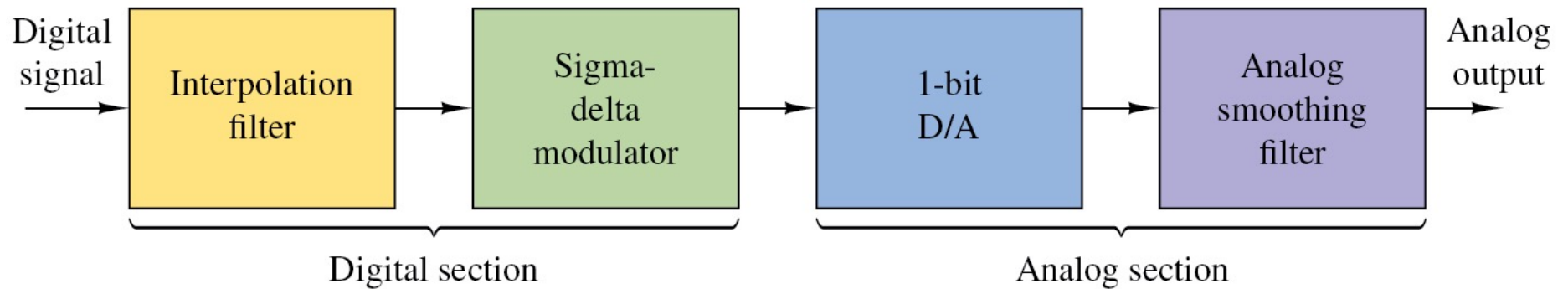

Figure P6.10

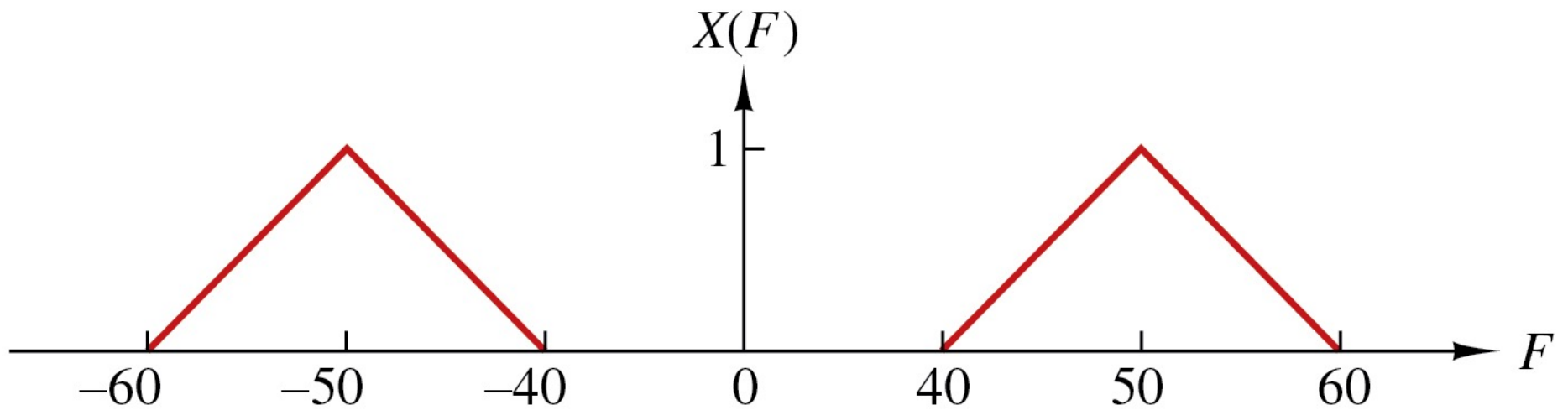

Figure P6.12

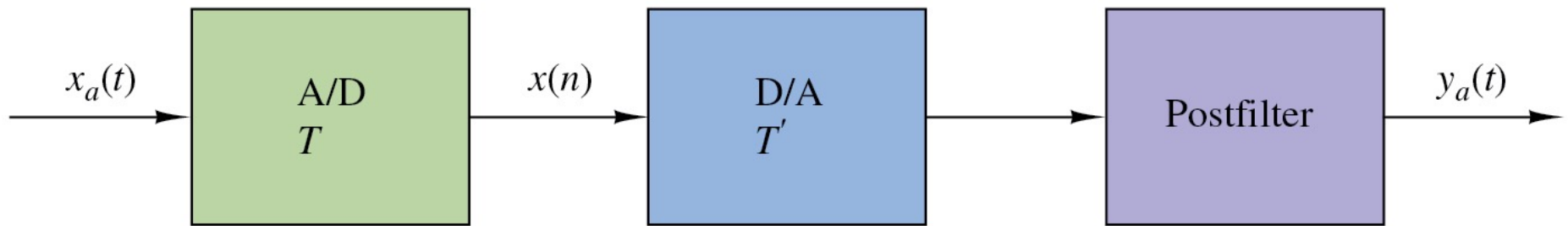

Figure P6.14

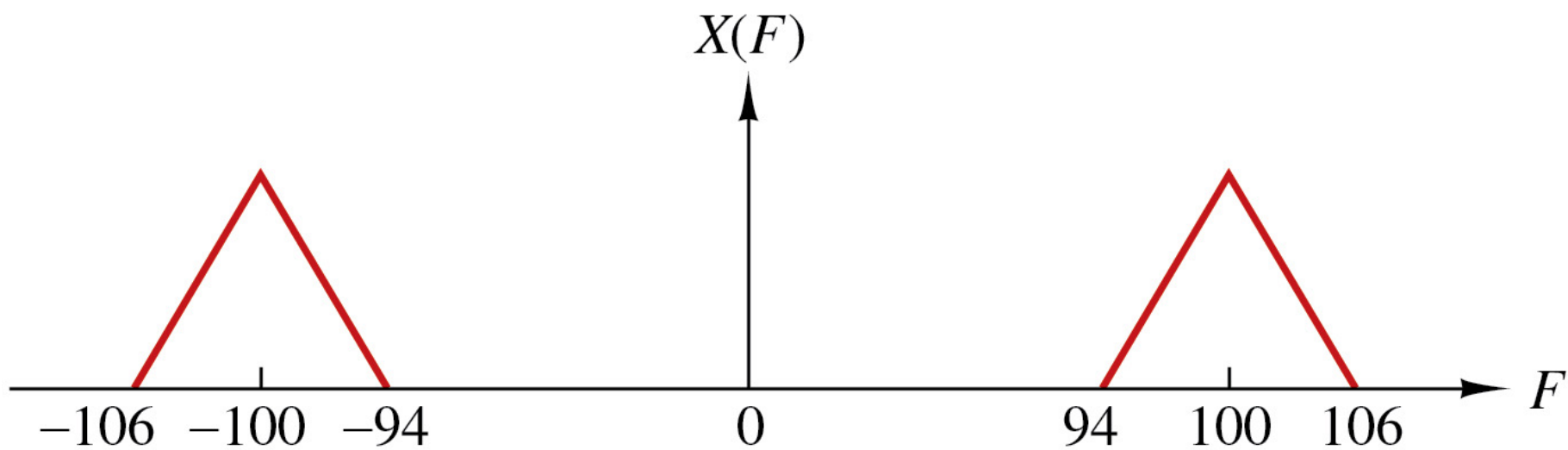
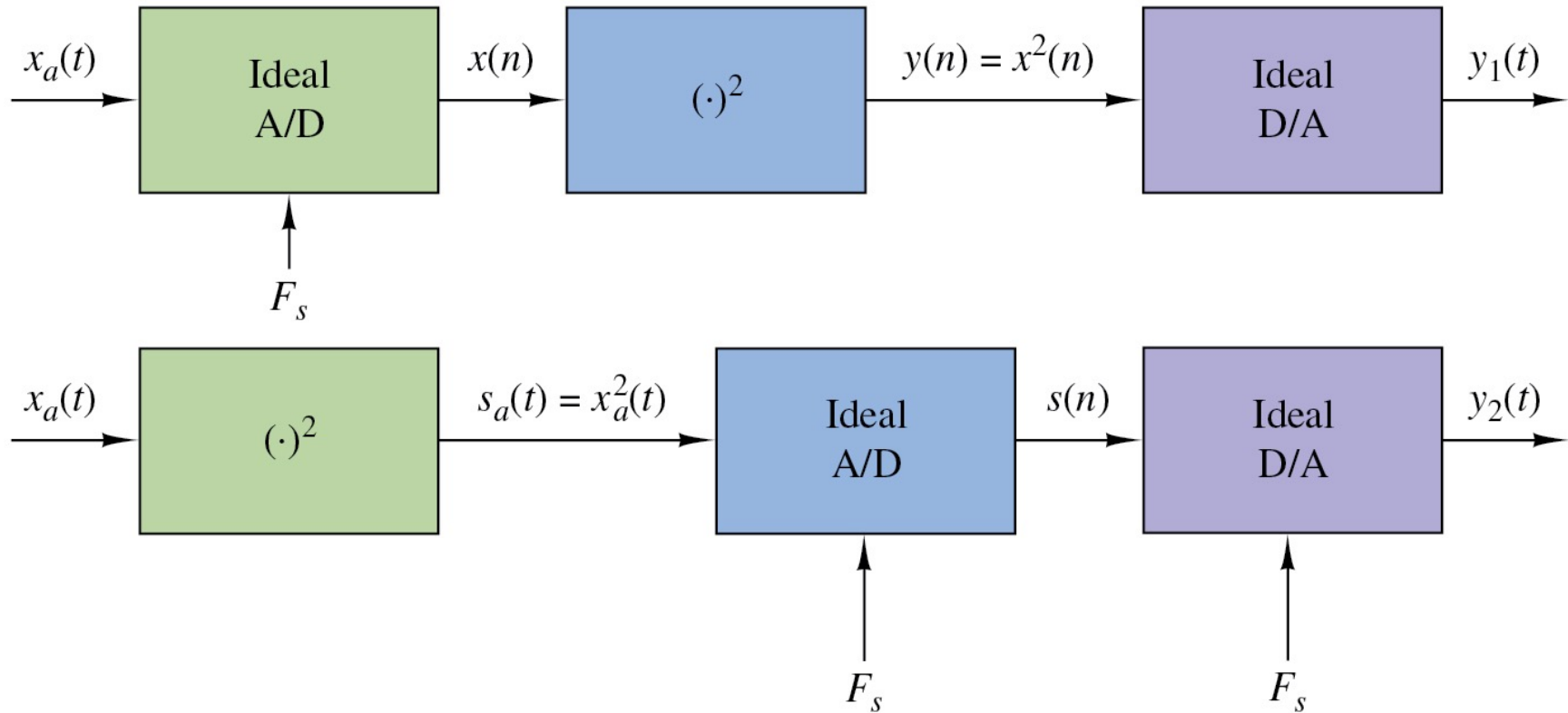
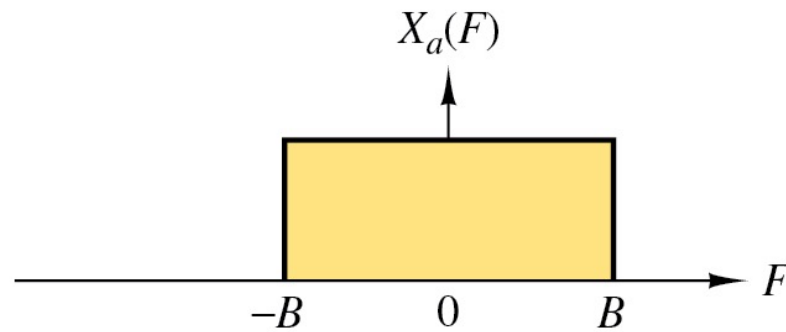

Figure P6.15



(a)



(b)

Figure P6.16

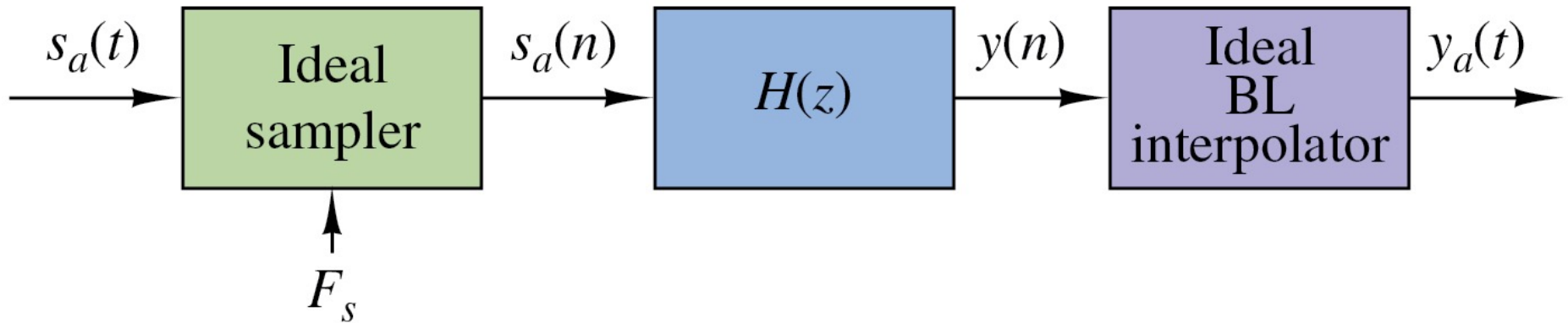

Figure P6.18

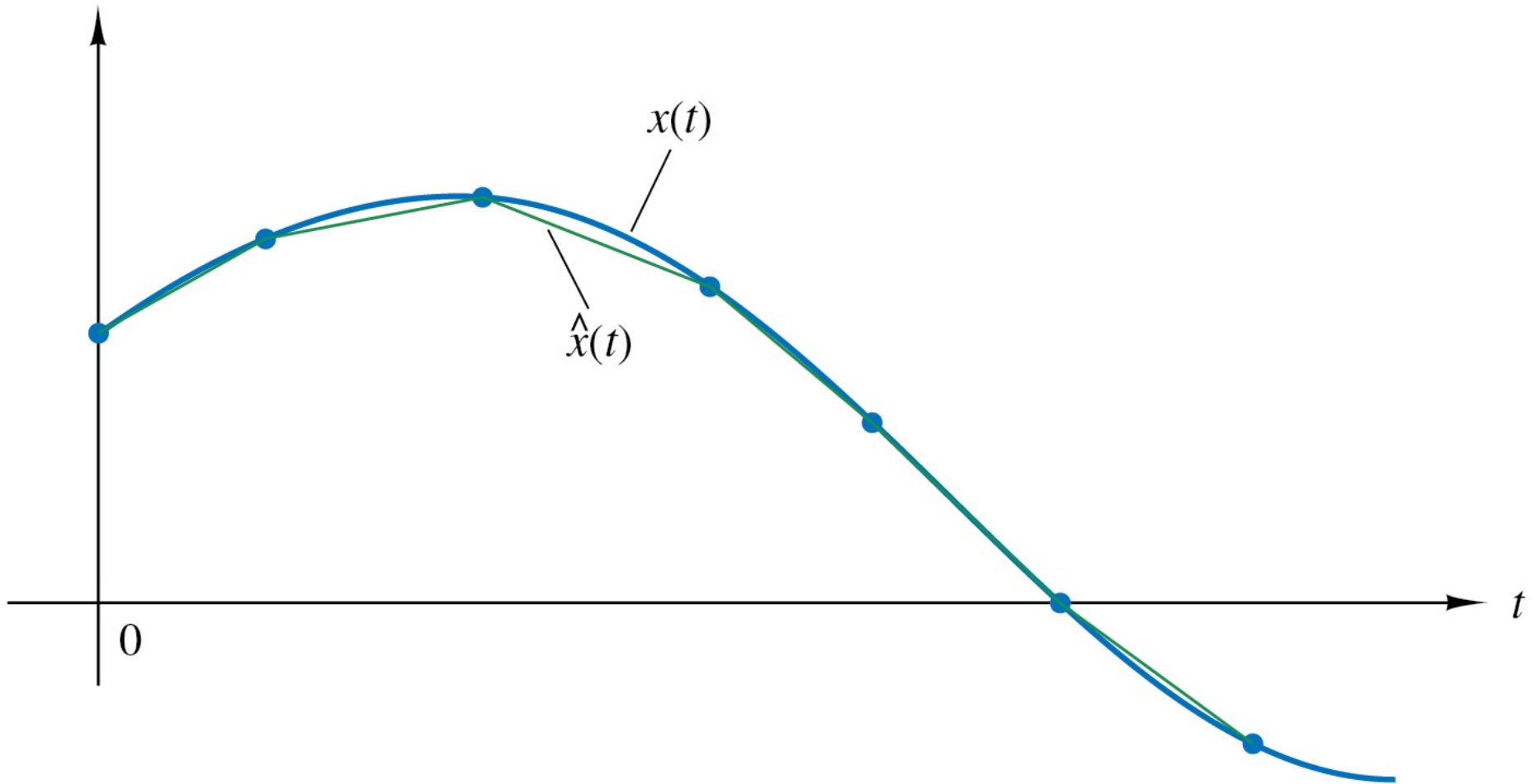

Figure P6.23

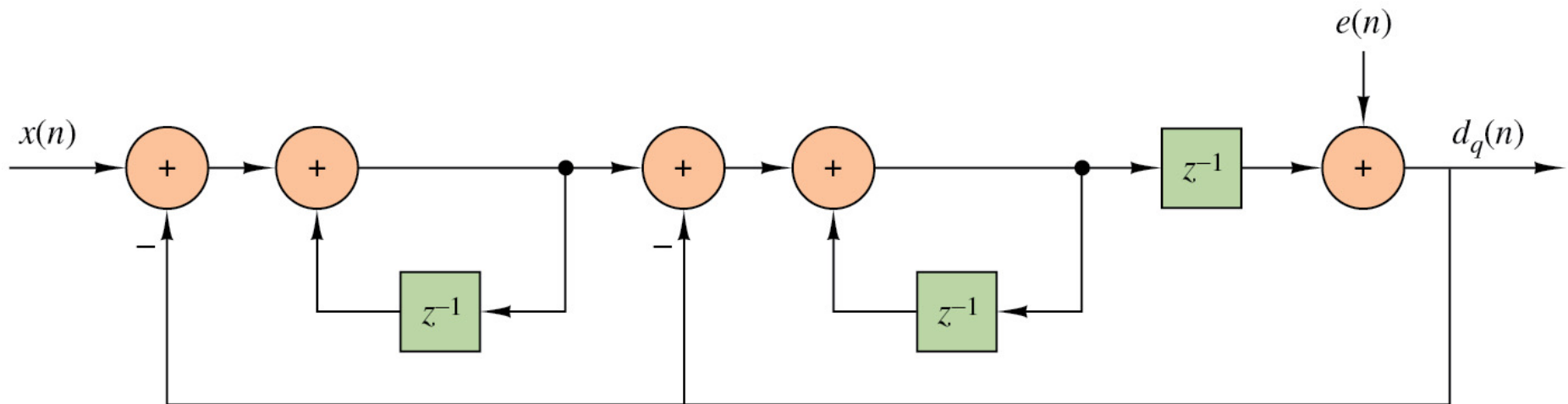

Figure P6.24

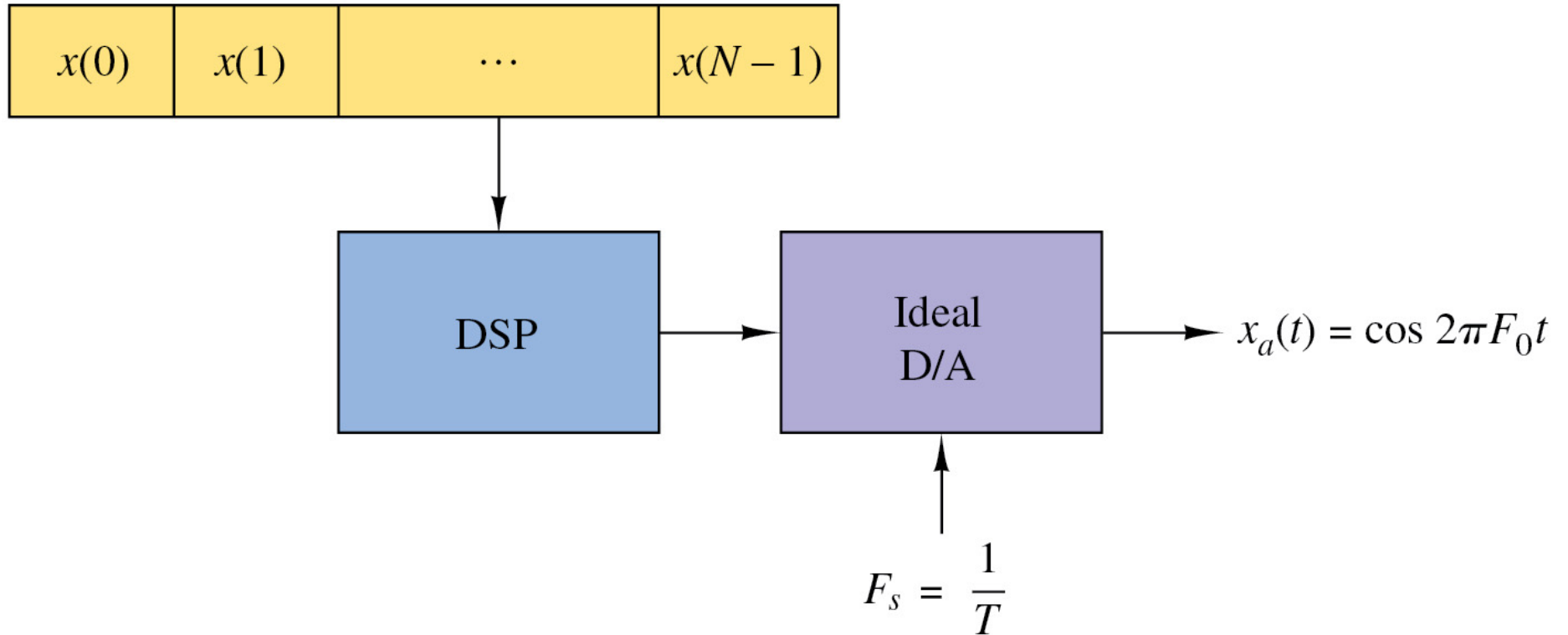

Figure P6.25

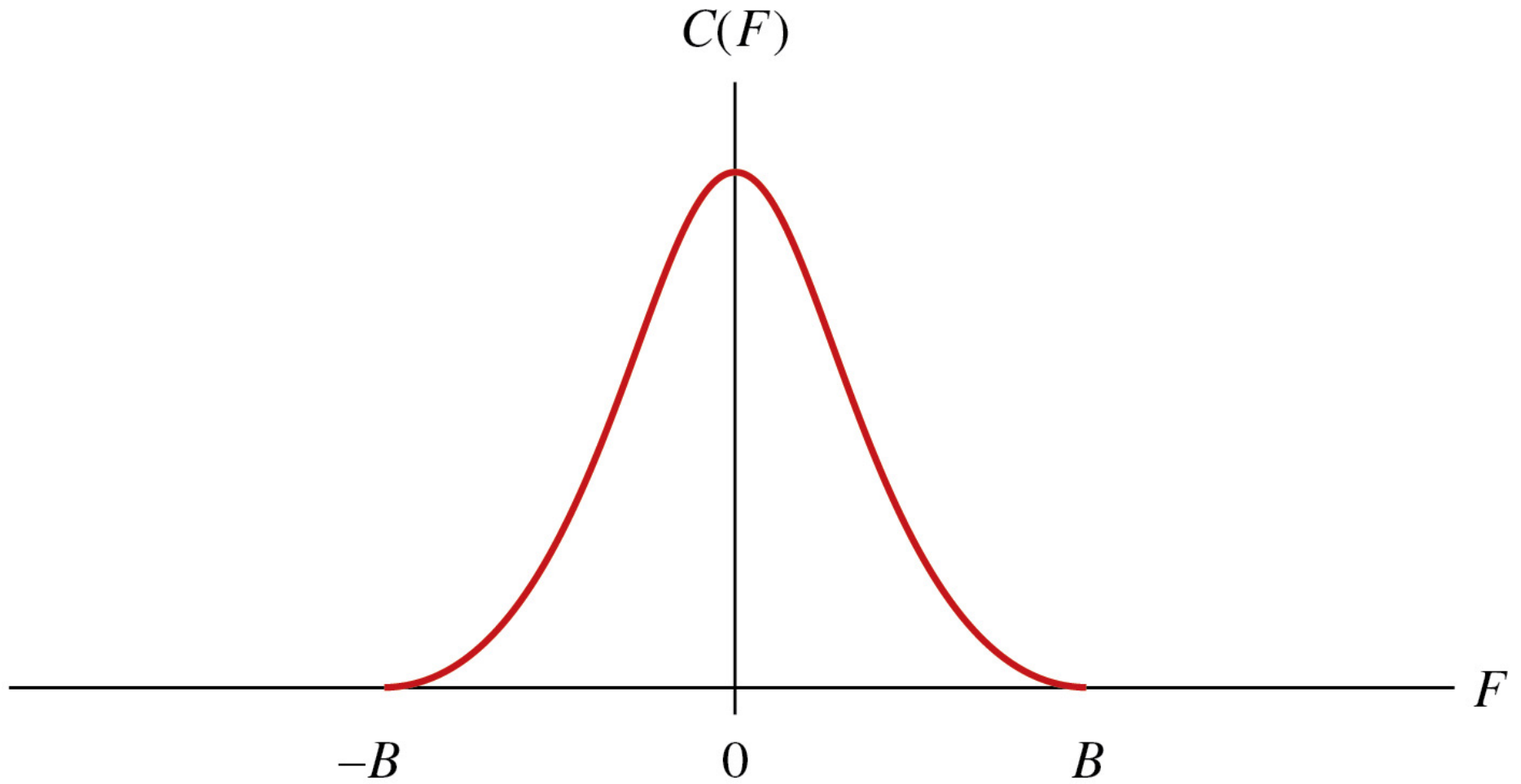

Figure CP6.4

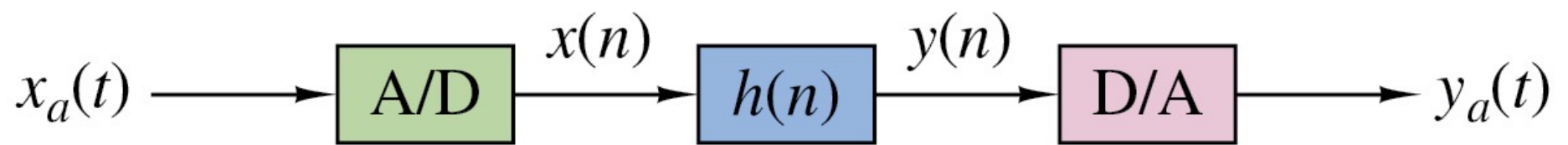
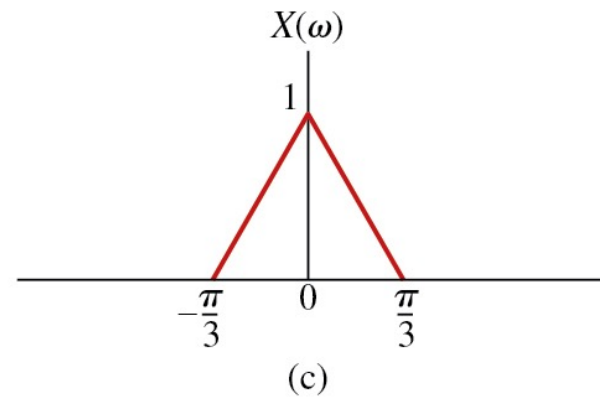
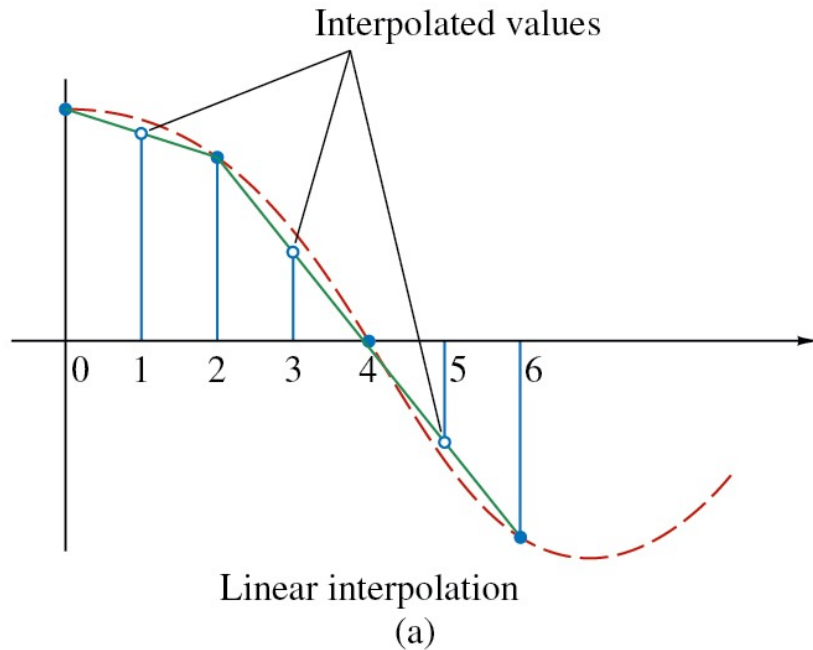
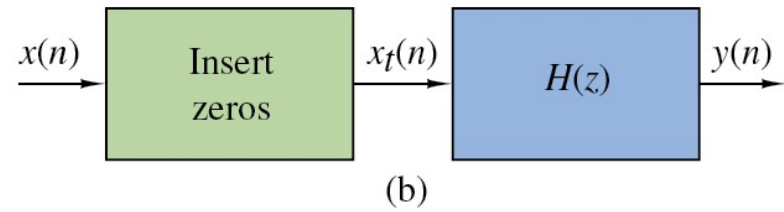
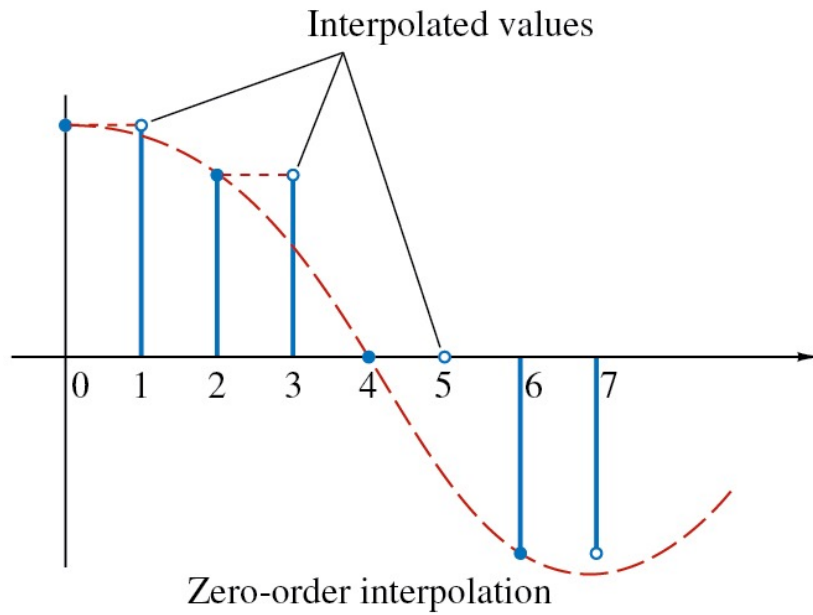

Figure CP6.8



Copyright



This work is protected by United States copyright laws and is provided solely for the use of instructors in teaching their courses and assessing student learning. Dissemination or sale of any part of this work (including on the World Wide Web) will destroy the integrity of the work and is not permitted. The work and materials from it should never be made available to students except by instructors using the accompanying text in their classes. All recipients of this work are expected to abide by these restrictions and to honor the intended pedagogical purposes and the needs of other instructors who rely on these materials.